

DATA SHEET

For a complete data sheet, please also download:

- The IC06 74HC/HCT/HCU/HCMOS Logic Family Specifications
- The IC06 74HC/HCT/HCU/HCMOS Logic Package Information
- The IC06 74HC/HCT/HCU/HCMOS Logic Package Outlines

74HC/HCT241

Octal buffer/line driver; 3-state

Product specification
File under Integrated Circuits, IC06

September 1993

Octal buffer/line driver; 3-state**74HC/HCT241****FEATURES**

- Output capability: bus driver
- I_{CC} category: MSI

GENERAL DESCRIPTION

The 74HC/HCT241 are high-speed Si-gate CMOS devices and are pin compatible with low power Schottky TTL (LSTTL). They are specified in compliance with JEDEC standard no. 7A.

The 74HC/HCT241 are octal non-inverting buffer/line drivers with 3-state outputs. The 3-state outputs are controlled by the output enable inputs $\overline{1OE}$ and 2OE.

QUICK REFERENCE DATA

GND = 0 V; T_{amb} = 25 °C; t_r = t_f = 6 ns

SYMBOL	PARAMETER	CONDITIONS	TYPICAL		UNIT
			HC	HCT	
t _{PHL} / t _{PLH}	propagation delay 1A _n to 1Y _n ; 2A _n to 2Y _n	C _L = 15 pF; V _{CC} = 5 V	7	11	ns
C _I	input capacitance		3.5	3.5	pF
C _{PD}	power dissipation capacitance per buffer	notes 1 and 2	30	30	pF

Notes

1. C_{PD} is used to determine the dynamic power dissipation (P_D in μW):

$$P_D = C_{PD} \times V_{CC}^2 \times f_i + \sum (C_L \times V_{CC}^2 \times f_o) \text{ where:}$$

f_i = input frequency in MHz

f_o = output frequency in MHz

∑ (C_L × V_{CC}² × f_o) = sum of outputs

C_L = output load capacitance in pF

V_{CC} = supply voltage in V

2. For HC the condition is V_I = GND to V_{CC}

For HCT the condition is V_I = GND to V_{CC} - 1.5 V

ORDERING INFORMATION

See "74HC/HCT/HCU/HCMOS Logic Package Information".

Octal buffer/line driver; 3-state

74HC/HCT241

PIN DESCRIPTION

PIN NO.	SYMBOL	NAME AND FUNCTION
1	$\overline{1OE}$	output enable input (active LOW)
2, 4, 6, 8	$1A_0$ to $1A_3$	data inputs
3, 5, 7, 9	$2Y_0$ to $2Y_3$	bus outputs
10	GND	ground (0 V)
17, 15, 13, 11	$2A_0$ to $2A_3$	data inputs
18, 16, 14, 12	$1Y_0$ to $1Y_3$	bus outputs
19	$2OE$	output enable input (active HIGH)
20	V_{CC}	positive supply voltage

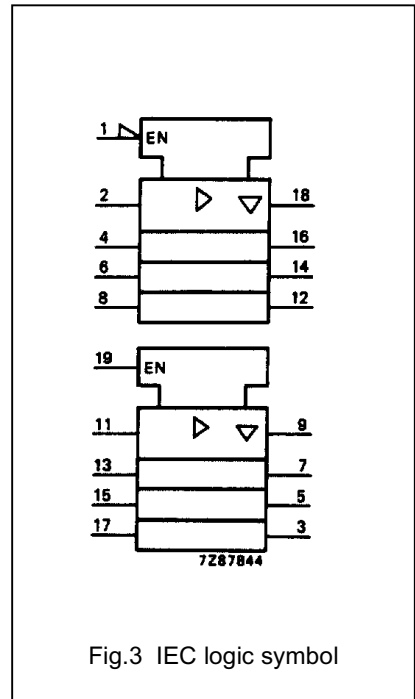
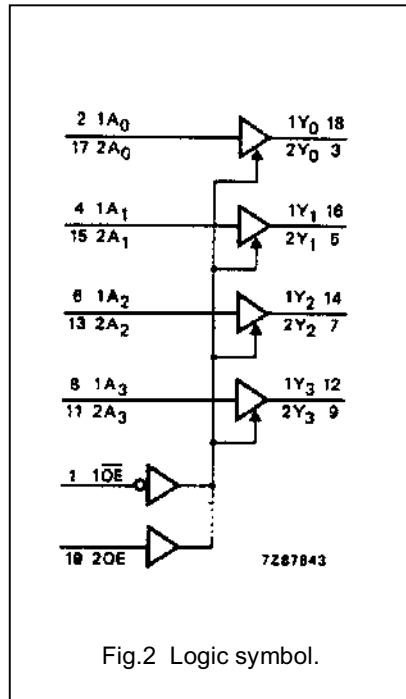
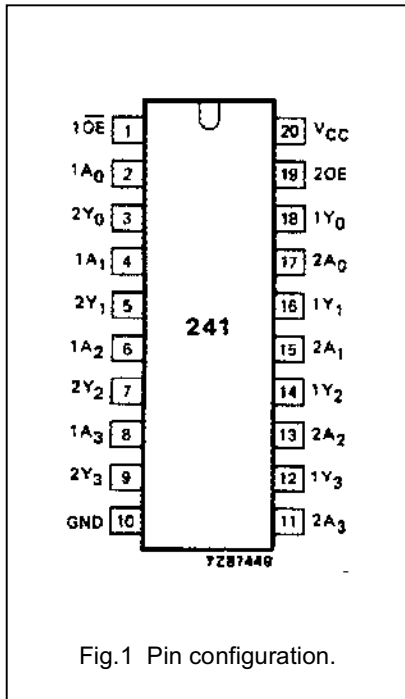

Octal buffer/line driver; 3-state

74HC/HCT241

FUNCTION TABLES

INPUTS		OUTPUT
$\overline{1OE}$	$1A_n$	$1Y_n$
L	L	L
L	H	H
H	X	Z

INPUTS		OUTPUT
$2OE$	$2A_n$	$2Y_n$
H	L	L
H	H	H
L	X	Z

Note

- H = HIGH voltage level
 L = LOW voltage level
 X = don't care
 Z = high impedance OFF-state

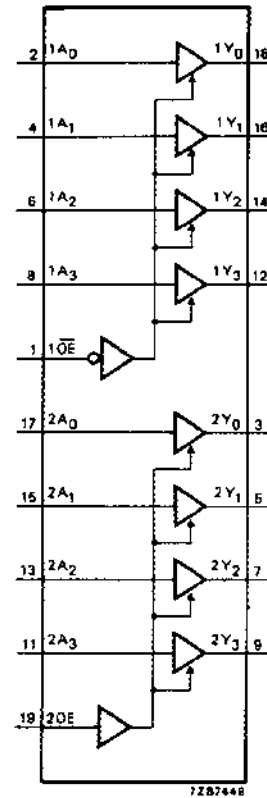

Fig.4 Functional diagram.

Octal buffer/line driver; 3-state

74HC/HCT241

DC CHARACTERISTICS FOR 74HC

For the DC characteristics see "74HC/HCT/HCU/HCMOS Logic Family Specifications".

Output capability: bus driver

I_{CC} category: MSI

AC CHARACTERISTICS FOR 74HC

GND = 0 V; t_r = t_f = 6 ns; C_L = 50 pF

SYMBOL	PARAMETER	T _{amb} (°C)							UNIT	TEST CONDITIONS	
		74HC								V _{CC} (V)	WAVEFORMS
		+25			-40 to +85		-40 to +125				
		min.	typ.	max.	min.	max.	min.	max.			
t _{PHL} / t _{PLH}	propagation delay 1A _n to 1Y _n ; 2A _n to 2Y _n		25 9 7	100 20 17		125 25 21		150 30 26	ns	2.0 4.5 6.0	Fig.5
t _{PZH} / t _{PZL}	3-state output enable time 1 $\overline{O}E$ to 1Y _n ; 2OE to 2Y _n		30 11 9	150 30 26		190 38 33		225 45 38	ns	2.0 4.5 6.0	Fig.6
t _{PHZ} / t _{PLZ}	3-state output disable time 1 $\overline{O}E$ to 1Y _n ; 2OE to 2Y _n		39 14 11	150 30 26		190 38 33		225 45 38	ns	2.0 4.5 6.0	Fig.6
t _{THL} / t _{TLH}	output transition time		14 5 4	60 12 10		75 15 13		90 18 15	ns	2.0 4.5 6.0	Fig.5

Octal buffer/line driver; 3-state

74HC/HCT241

DC CHARACTERISTICS FOR 74HCT

For the DC characteristics see "74HC/HCT/HCU/HCMOS Logic Family Specifications".

Output capability: bus driver

I_{CC} category: MSI

Note to HCT types

The value of additional quiescent supply current (ΔI_{CC}) for a unit load of 1 is given in the family specifications.

To determine ΔI_{CC} per input, multiply this value by the unit load coefficient shown in the table below.

INPUT	UNIT LOAD COEFFICIENT
1A _n	0.70
2A _n	0.70
1OE	0.70
2OE	1.50

AC CHARACTERISTICS FOR 74HCT

GND = 0 V; t_r = t_f = 6 ns; C_L = 50 pF

SYMBOL	PARAMETER	T _{amb} (°C)						UNIT	TEST CONDITIONS		
		74HCT							V _{CC} (V)	WAVEFORMS	
		+25			-40 to +85		-40 to +125				
		min.	typ.	max.	min.	max.	min.				max.
t _{PHL} / t _{PLH}	propagation delay 1A _n to 1Y _n ; 2A _n to 2Y _n		13	22		28		33	ns	4.5	Fig.5
t _{PZH} / t _{PZL}	3-state output enable time 1OE to 1Y _n ; 2OE to 2Y _n		15	30		38		45	ns	4.5	Fig.6
t _{PHZ} / t _{PLZ}	3-state output disable time 1OE to 1Y _n ; 2OE to 2Y _n		18	30		38		45	ns	4.5	Fig.6
t _{THL} / t _{TLH}	output transition time		5	12		15		18	ns	4.5	Fig.5

Octal buffer/line driver; 3-state

74HC/HCT241

AC WAVEFORMS

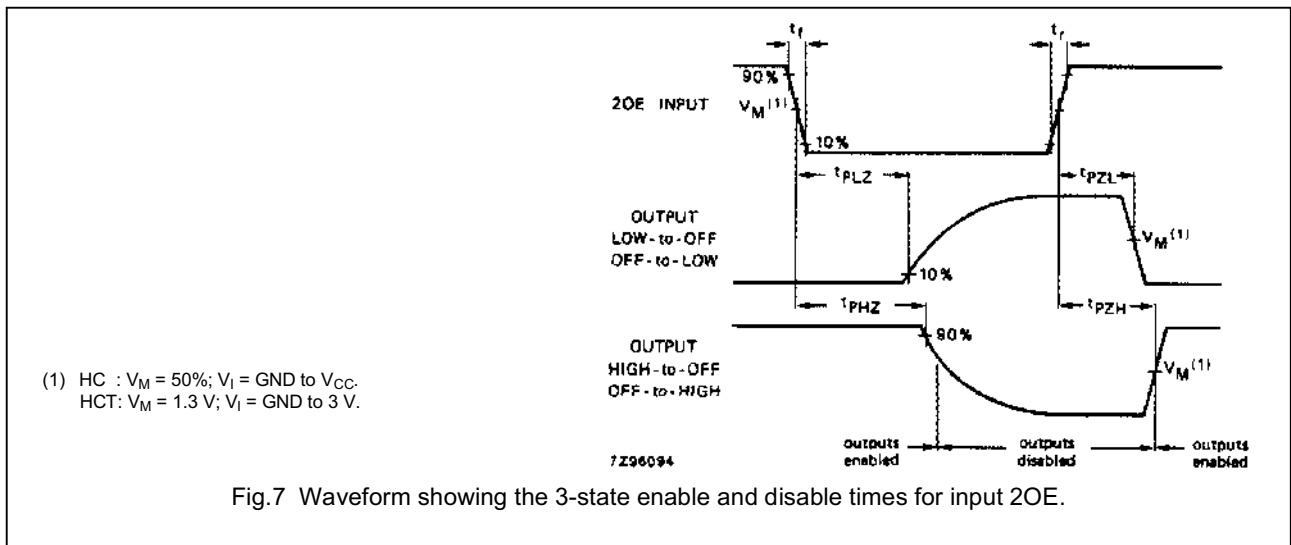
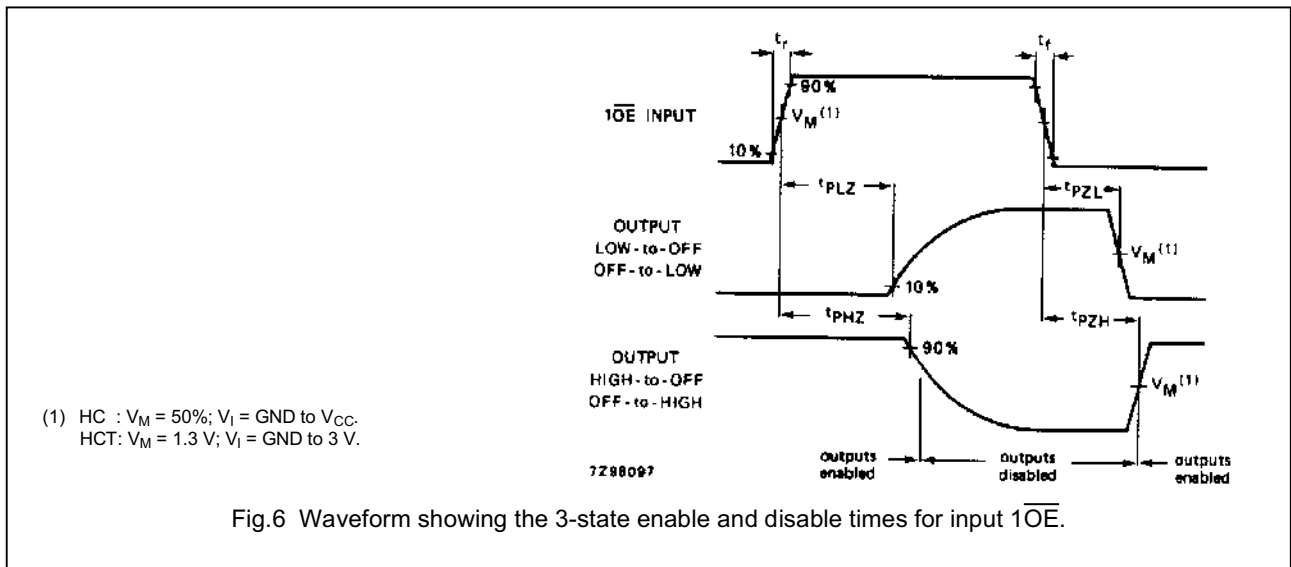
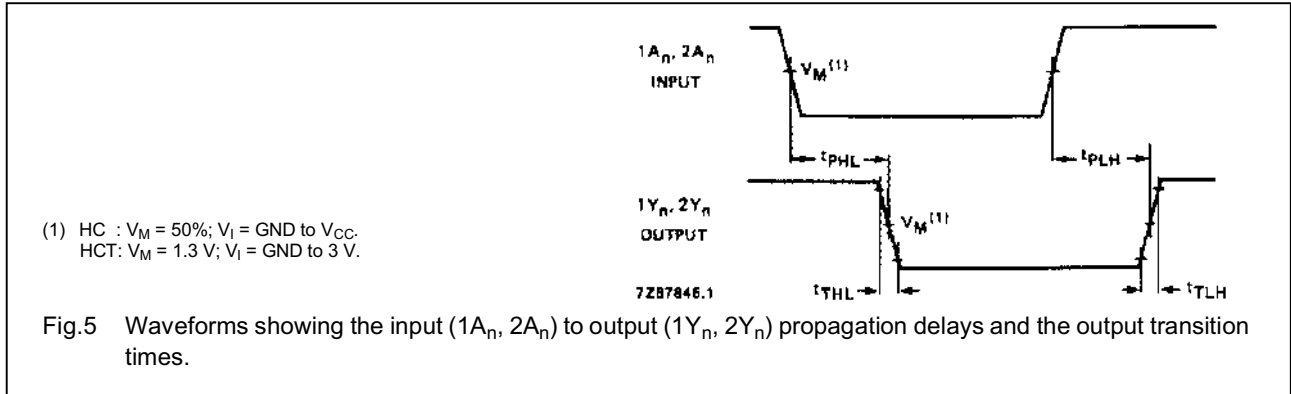

Octal buffer/line driver; 3-state

74HC/HCT241

PACKAGE OUTLINES

See "74HC/HCT/HCU/HCMOS Logic Package Outlines".