

74F366•74F368 Hex Inverter Buffer with TRI-STATE® Outputs

Features

- TRI-STATE buffer outputs sink 64 mA
- High-speed
- Bus-oriented
- High impedance npn base inputs for reduced loading

Commercial	Package Number	Package Description
74F366PC	N16E	16-Lead (0.300" Wide) Molded Dual-in-Line
74F366SC (Note 1)	M16A	16-Lead (0.150" Wide) Molded Small Outline, JEDEC
74F368PC	N16E	16-Lead (0.300" Wide) Molded Dual-in-Line
74F368SC (Note 1)	M16A	16-Lead (0.150" Wide) Molded Small Outline, JEDEC
74F368SJ (Note 1)	M16D	16-Lead (0.300" Wide) Molded Small Outline, EIAJ

Note 1: Devices also available in 13" reel. Use suffix = SCX.

Connection Diagrams

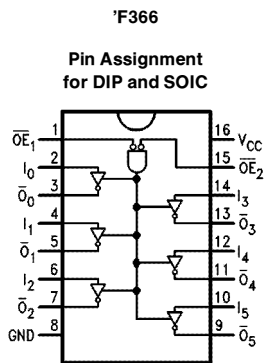

TL/F/9521-2

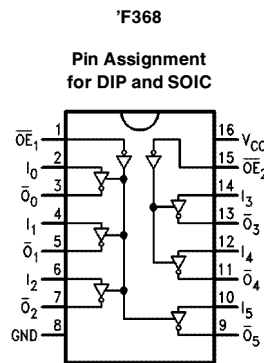

TL/F/9521-4

TRI-STATE® is a registered trademark of National Semiconductor Corporation.

Logic Symbols

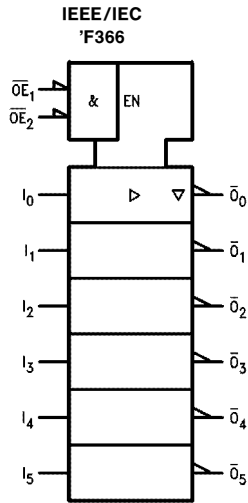

TL/F/9521-5

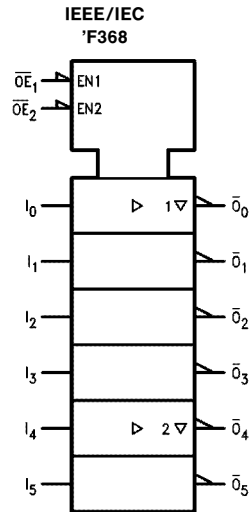

TL/F/9521-6

Unit Loading/Fan Out

Pin Names	Description	74F	
		U.L. HIGH/LOW	Input I_{IH}/I_{IL} Output I_{OH}/I_{OL}
$\overline{OE}_1, \overline{OE}_2$	Output Enable Input (Active LOW)	1.0/0.033	20 μ A/ -20 μ A
I_n	Input	1.0/0.033	20 μ A/ -20 μ A
O_n, \overline{O}_n	Outputs	600/106.6 (80)	-12 mA/64 mA (48 mA)

Function Tables

'F366

Inputs			Output
\overline{OE}_1	\overline{OE}_2	I	\overline{O}
L	L	L	H
L	L	H	L
X	H	X	Z
H	X	X	Z

'F368

Inputs		Output
\overline{OE}	I	\overline{O}
L	L	H
L	H	L
H	X	Z

L = LOW Voltage Level
H = HIGH Voltage Level
X = Immaterial
Z = High Impedance

Absolute Maximum Ratings (Note 1)

Storage Temperature	-65°C to +150°C
Ambient Temperature under Bias	-55°C to +125°C
Junction Temperature under Bias	-55°C to +175°C
Plastic	-55°C to +150°C
V _{CC} Pin Potential to Ground Pin	-0.5V to +7.0V
Input Voltage (Note 2)	-0.5V to +7.0V
Input Current (Note 2)	-30 mA to +5.0 mA
Voltage Applied to Output in HIGH State (with V _{CC} = 0V)	
Standard Output	-0.5V to V _{CC}
TRI-STATE Output	-0.5V to +5.5V
Current Applied to Output in LOW State (Max)	twice the rated I _{OL} (mA)

Note 1: Absolute maximum ratings are values beyond which the device may be damaged or have its useful life impaired. Functional operation under these conditions is not implied.

Note 2: Either voltage limit or current limit is sufficient to protect inputs.

Recommended Operating Conditions

Free Air Ambient Temperature	0°C to +70°C
Commercial	
Supply Voltage	+4.5V to +5.5V
Commercial	

DC Electrical Characteristics

Symbol	Parameter	74F			Units	V _{CC}	Conditions
		Min	Typ	Max			
V _{IH}	Input HIGH Voltage	2.0			V		Recognized as a HIGH Signal
V _{IL}	Input LOW Voltage			0.8	V		Recognized as a LOW Signal
V _{CD}	Input Clamp Diode Voltage			-1.2	V	Min	I _{IN} = -18 mA
V _{OH}	Output HIGH Voltage 74F 10% V _{CC}	2.0			V	Min	I _{OH} = -15 mA
V _{OL}	Output LOW Voltage 74F 10% V _{CC}			0.55	V	Min	I _{OL} = 64 mA
I _{IH}	Input HIGH Current			20	μA	Max	V _{IN} = 2.7V
I _{BVI}	Input HIGH Current Breakdown Test			100	μA	Max	V _{IN} = 7.0V
I _{IL}	Input LOW Current			-20	μA	Max	V _{IN} = 0.5V
I _{OZH}	Output Leakage Current			50	μA	Max	V _{OUT} = 2.7V
I _{OZL}	Output Leakage Current			-50	μA	Max	V _{OUT} = 0.5V
I _{OS}	Output Short-Circuit Current	-100		-225	mA	Max	V _{OUT} = 0V
I _{CEX}	Output HIGH Leakage Current			250	μA	Max	V _{OUT} = V _{CC}
I _{ZZ}	Bus Drainage Test			500	μA	0.0V	V _{OUT} = 5.25V
I _{CCH}	Power Supply Current		20	25	mA	Max	V _O = HIGH
I _{CCL}	Power Supply Current		49	62	mA	Max	V _O = LOW
I _{CCZ}	Power Supply Current		35	48	mA	Max	V _O = HIGH Z

AC Electrical Characteristics

Symbol	Parameter	74F			74F		Units
		T _A = +25°C V _{CC} = +5.0V C _L = 50 pF			T _A , V _{CC} = Com C _L = 50 pF		
		Min	Typ	Max	Min	Max	
t _{PLH} t _{PHL}	Propagation Delay	2.5 1.0	4.0 1.8	6.5 5.0	2.0 1.0	7.5 5.5	ns
t _{PZH} t _{PZL}	Enable Time ('F366)	2.5 2.5	4.2 4.2	9.5 9.0	2.5 2.5	10.0 9.5	ns
t _{PZH} t _{PZL}	Enable Time ('F368)	2.5 3.0	4.2 5.6	7.5 8.5	2.0 3.0	8.5 9.0	ns
t _{PHZ} t _{PLZ}	Disable Time	2.0 2.0	3.3 4.1	6.5 6.5	2.0 2.0	7.0 7.0	ns

Ordering Information

The device number is used to form part of a simplified purchasing code where the package type and temperature range are defined as follows:

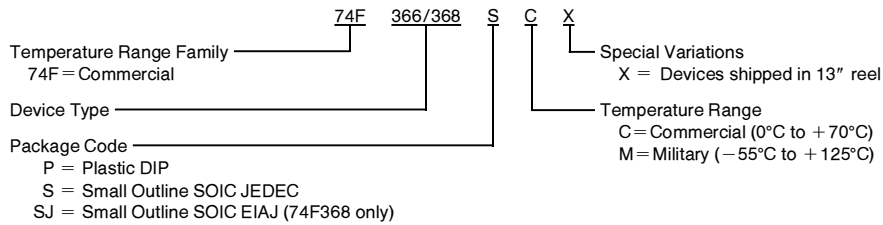

Physical Dimensions inches (millimeters)

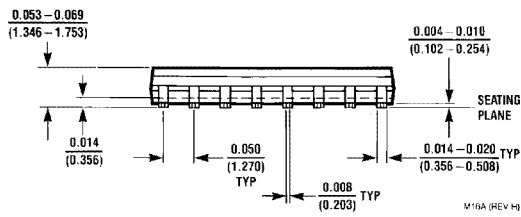
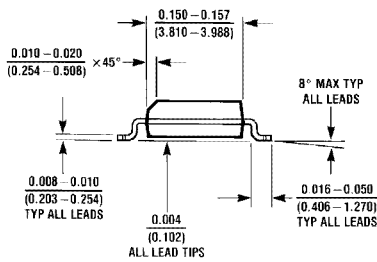
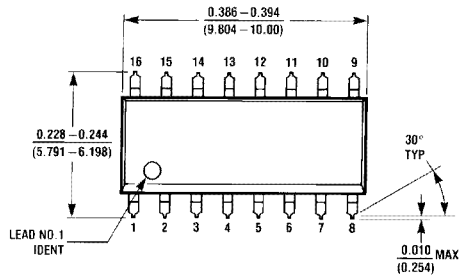

**16-Lead Small Outline Integrated Circuit (S)
NS Package Number M16A**

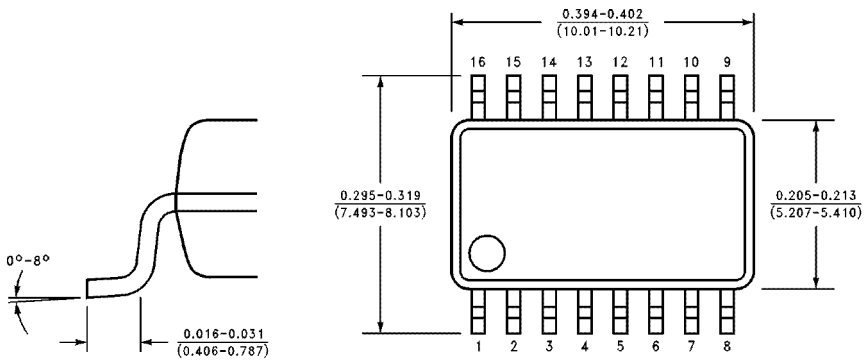

DETAIL F

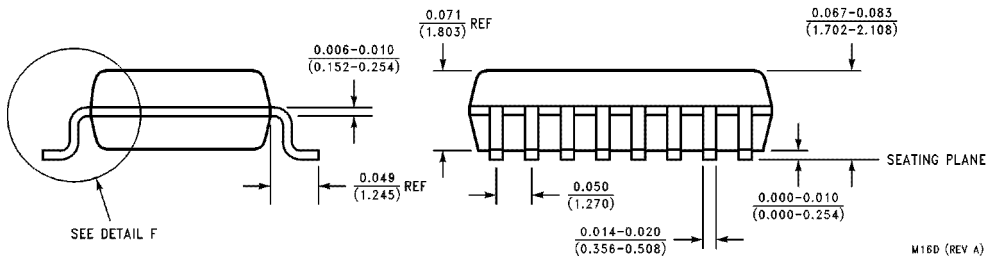

**16-Lead (0.300" Wide) Molded Small Outline Package, EIAJ (SJ)
NS Package Number M16D**

Physical Dimensions inches (millimeters) (Continued)

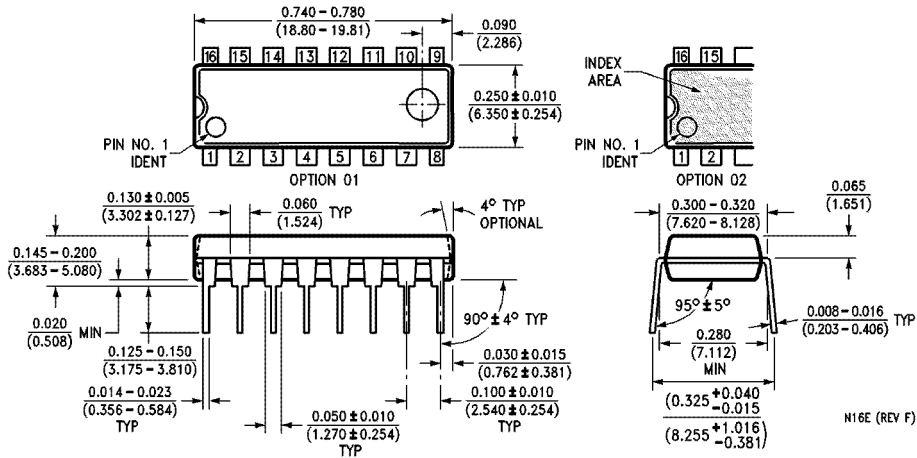

**16-Lead (0.300" Wide) Molded Dual-In-Line Package (P)
NS Package Number N16E**

LIFE SUPPORT POLICY

NATIONAL'S PRODUCTS ARE NOT AUTHORIZED FOR USE AS CRITICAL COMPONENTS IN LIFE SUPPORT DEVICES OR SYSTEMS WITHOUT THE EXPRESS WRITTEN APPROVAL OF THE PRESIDENT OF NATIONAL SEMICONDUCTOR CORPORATION. As used herein:

1. Life support devices or systems are devices or systems which, (a) are intended for surgical implant into the body, or (b) support or sustain life, and whose failure to perform, when properly used in accordance with instructions for use provided in the labeling, can be reasonably expected to result in a significant injury to the user.
2. A critical component is any component of a life support device or system whose failure to perform can be reasonably expected to cause the failure of the life support device or system, or to affect its safety or effectiveness.



National Semiconductor Corporation
1111 West Bardin Road
Arlington, TX 76017
Tel: 1(800) 272-9959
Fax: 1(800) 737-7018

National Semiconductor Europe
Fax: (+49) 0-180-530 85 86
Email: cnjwge@tevm2.nsc.com
Deutsch Tel: (+49) 0-180-530 85 85
English Tel: (+49) 0-180-532 78 32
Français Tel: (+49) 0-180-532 93 58
Italiano Tel: (+49) 0-180-534 16 80

National Semiconductor Hong Kong Ltd.
13th Floor, Straight Block,
Ocean Centre, 5 Canton Rd.
Tsimshatsui, Kowloon
Hong Kong
Tel: (852) 2737-1600
Fax: (852) 2736-9960

National Semiconductor Japan Ltd.
Tel: 81-043-299-2309
Fax: 81-043-299-2408

National does not assume any responsibility for use of any circuitry described, no circuit patent licenses are implied and National reserves the right at any time without notice to change said circuitry and specifications.