

54F/74F182 Carry Lookahead Generator

General Description

The 'F182 is a high-speed carry lookahead generator. It is generally used with the 'F181 or 'F381 4-bit arithmetic logic units to provide high-speed lookahead over word lengths of more than four bits.

Features

- Provides lookahead carries across a group of four ALUs
- Multi-level lookahead high-speed arithmetic operation over long word lengths
- Guaranteed 4000V minimum ESD protection

Commercial	Military	Package Number	Package Description
74F182PC		N16E	16-Lead (0.300" Wide) Molded Dual-In-Line
	54F182DM (Note 2)	J16A	16-Lead Ceramic Dual-In-Line
74F182SJ (Note 1)		M16D	16-Lead (0.300" Wide) Molded Small Outline, EIAJ
	54F182FM (Note 2)	W16A	16-Lead Cerpack
	54F182LM (Note 2)	E20A	20-Lead Ceramic Leadless Chip Carrier, Type C

Note 1: Devices also available in 13" reel. Use suffix = SCX and SJX.

Note 2: Military grade device with environmental and burn-in processing. Use suffix = DMQB, FMQB and LMQB

Logic Symbols

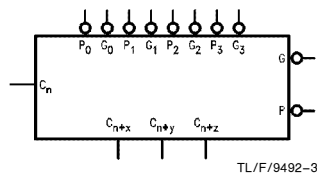
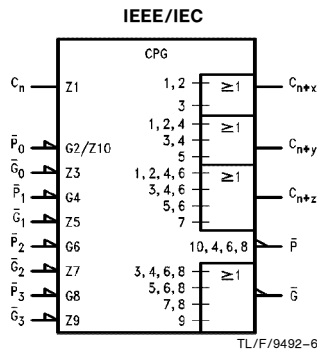

Connection Diagrams

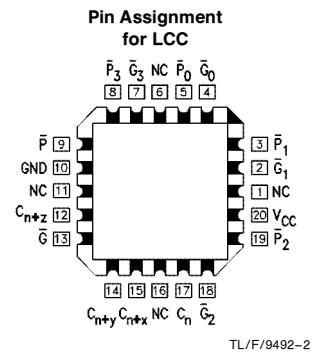
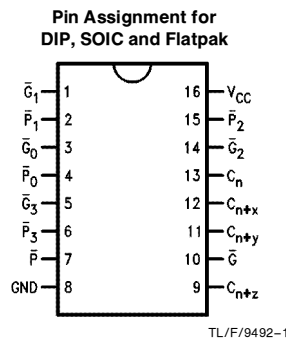

TRI-STATE® is a registered trademark of National Semiconductor Corporation.

Unit Loading/Fan Out

Pin Names	Description	54F/74F	
		U.L. HIGH/LOW	Input I _{IH} /I _{IL} Output I _{OH} /I _{OL}
C _n	Carry Input	1.0/2.0	20 μA/−1.2 mA
$\overline{G}_0, \overline{G}_2$	Carry Generate Inputs (Active LOW)	1.0/14.0	20 μA/−8.4 mA
\overline{G}_1	Carry Generate Input (Active LOW)	1.0/16.0	20 μA/−9.6 mA
\overline{G}_3	Carry Generate Input (Active LOW)	1.0/8.0	20 μA/−4.8 mA
$\overline{P}_0, \overline{P}_1$	Carry Propagate Inputs (Active LOW)	1.0/8.0	20 μA/−4.8 mA
\overline{P}_2	Carry Propagate Input (Active LOW)	1.0/6.0	20 μA/−3.6 mA
\overline{P}_3	Carry Propagate Input (Active LOW)	1.0/4.0	20 μA/−2.4 mA
C _{n+x} –C _{n+z}	Carry Outputs	50/33.3	−1 mA/20 mA
\overline{G}	Carry Generate Output (Active LOW)	50/33.3	−1 mA/20 mA
\overline{P}	Carry Propagate Output (Active LOW)	50/33.3	−1 mA/20 mA

Functional Description

The 'F182 carry lookahead generator accepts up to four pairs of Active LOW Carry Propagate (\overline{P}_0 – \overline{P}_3) and Carry Generate (\overline{G}_0 – \overline{G}_3) signals and an Active HIGH Carry input (C_n) and provides anticipated Active HIGH carries (C_{n+x}, C_{n+y}, C_{n+z}) across four groups of binary adders. The 'F182 also has Active LOW Carry Propagate (\overline{P}) and Carry Generate (\overline{G}) outputs which may be used for further levels of lookahead. The logic equations provided at the outputs are:

$$C_{n+x} = G_0 + P_0C_n$$

$$C_{n+y} = G_1 + P_1G_0 + P_1P_0C_n$$

$$C_{n+z} = G_2 + P_2G_1 + P_2P_1G_0 + P_2P_1P_0C_n$$

$$G = G_3 + P_3G_2 + P_3P_2G_1 + P_3P_2P_1G_0$$

$$P = P_2P_2P_1P_0$$

Also, the 'F182 can be used with binary ALUs in an active LOW or active HIGH input operand mode. The connections (Figure 1) to and from the ALU to the carry lookahead generator are identical in both cases. Carries are rippled between lookahead blocks. The critical speed path follows the circled numbers. There are several possible arrangements for the carry interconnects, but all achieve about the same speed. A 28-bit ALU is formed by dropping the last 'F181 or 'F381.

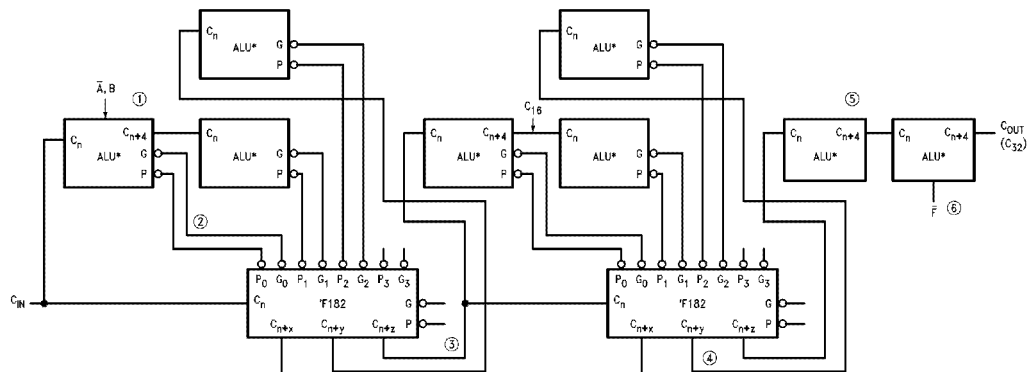

FIGURE 1. 32-Bit ALU with Rippled Carry between 16-Bit Lookahead ALUs

*ALUs may be either 'F181 or 'F381

TL/F/9492-5

Truth Table

Inputs									Outputs				
C_n	\bar{G}_0	\bar{P}_0	\bar{G}_1	\bar{P}_1	\bar{G}_2	\bar{P}_2	\bar{G}_3	\bar{P}_3	C_{n+x}	C_{n+y}	C_{n+z}	\bar{G}	\bar{P}
X	H	H							L				
L	H	X							L				
X	L	X							L				
H	X	L							H				
X	X	X	H	H						L			
L	H	X	H	X						L			
X	H	X	H	X						L			
X	X	X	L	X						L			
X	L	X	X	L						H			
H	X	L	X	L						H			
X	X	X	X	X	H	H					L		
X	X	X	H	H	H	X				L			
X	H	H	H	X	H	X				L			
L	H	X	H	X	H	X				L			
X	X	X	X	X	L	X				L			
X	X	X	L	X	X	L				H			
X	L	X	X	L	X	L				H			
H	X	L	X	L	X	L				H			
			X	X	X	X	H	H				H	
			X	X	H	H	H	X				H	
			X	H	H	X	H	X				H	
			X	X	X	X	L	X				L	
			X	X	X	L	X	X				L	
			X	X	X	L	X	L				L	
			X	L	X	X	L	X				L	
			X	L	X	L	X	L				L	
		H		X		X		X					H
		X		H		X		X					H
		X		X		H		X					H
		X		X		X		H					H
		L		L		L		L					L

H = HIGH Voltage Level
L = LOW Voltage Level
X = Immaterial

Logic Diagram

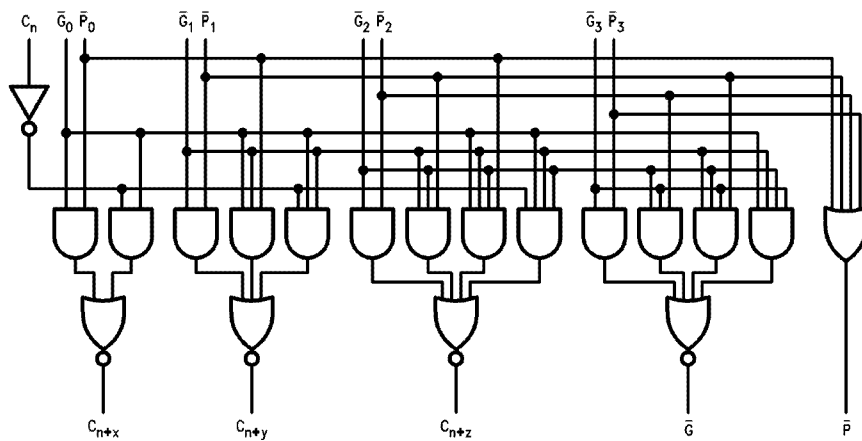

TL/F/9492-4

Please note that this diagram is provided only for the understanding of logic operations and should not be used to estimate propagation delays.

Absolute Maximum Ratings (Note 1)

If Military/Aerospace specified devices are required, please contact the National Semiconductor Sales Office/Distributors for availability and specifications.

Storage Temperature	-65°C to +150°C
Ambient Temperature under Bias	-55°C to +125°C
Junction Temperature under Bias	-55°C to +175°C
Plastic	-55°C to +150°C

V_{CC} Pin Potential to Ground Pin -0.5V to +7.0V

Input Voltage (Note 2) -0.5V to +7.0V

Input Current (Note 2) -30 mA to +5.0 mA

Voltage Applied to Output in HIGH State (with V_{CC} = 0V)
 Standard Output -0.5V to V_{CC}
 TRI-STATE® Output -0.5V to +5.5V

Current Applied to Output in LOW State (Max) twice the rated I_{OL} (mA)

ESD Last Passing Voltage (Min) 4000V

Note 1: Absolute maximum ratings are values beyond which the device may be damaged or have its useful life impaired. Functional operation under these conditions is not implied.

Note 2: Either voltage limit or current limit is sufficient to protect inputs.

Recommended Operating Conditions

Free Air Ambient Temperature	
Military	-55°C to +125°C
Commercial	0°C to +70°C
Supply Voltage	
Military	+4.5V to +5.5V
Commercial	+4.5V to +5.5V

DC Electrical Characteristics

Symbol	Parameter	54F/74F			Units	V _{CC}	Conditions
		Min	Typ	Max			
V _{IH}	Input HIGH Voltage	2.0			V		Recognized as a HIGH Signal
V _{IL}	Input LOW Voltage			0.8	V		Recognized as a LOW Signal
V _{CD}	Input Clamp Diode Voltage			-1.2	V	Min	I _{IN} = -18 mA
V _{OH}	Output HIGH Voltage	54F 10% V _{CC} 74F 10% V _{CC} 74F 5% V _{CC}	2.5 2.5 2.7		V	Min	I _{OH} = -1 mA I _{OH} = -1 mA I _{OH} = -1 mA
V _{OL}	Output LOW Voltage	54F 10% V _{CC} 74F 10% V _{CC}		0.5 0.5	V	Min	I _{OL} = 20 mA I _{OL} = 20 mA
I _{IH}	Input HIGH Current	54F 74F		20.0 5.0	μA	Max	V _{IN} = 2.7V
I _{BVI}	Input HIGH Current Breakdown Test	54F 74F		100 7.0	μA	Max	V _{IN} = 7.0V
I _{CEX}	Output HIGH Leakage Current	54F 74F		250 50	μA	Max	V _{OUT} = V _{CC}
V _{ID}	Input Leakage Test	74F	4.75		V	0.0	I _{ID} = 1.9 μA All Other Pins Grounded
I _{OD}	Output Leakage Circuit Current	74F		3.75	μA	0.0	V _{IOD} = 150 mV All Other Pins Grounded
I _{IL}	Input LOW Current			-1.2 -2.4 -3.6 -4.8 -8.4 -9.6	mA	Max	V _{IN} = 0.5V (C _n) V _{IN} = 0.5V (P ₃) V _{IN} = 0.5V (P ₂) V _{IN} = 0.5V (G ₃ , P ₀ , P ₁) V _{IN} = 0.5V (G ₀ , G ₂) V _{IN} = 0.5V (G ₁)
I _{OS}	Output Short-Circuit Current		-60	-150	mA	Max	V _{OUT} = 0V
I _{CCH}	Power Supply Current		18.4	28.0	mA	Max	V _O = HIGH
I _{CCL}	Power Supply Current		23.5	36.0	mA	Max	V _O = LOW

AC Electrical Characteristics

Symbol	Parameter	74F			54F		74F		Units
		T _A = +25°C V _{CC} = +5.0V C _L = 50 pF			T _A , V _{CC} = Mil C _L = 50 pF		T _A , V _{CC} = Com C _L = 50 pF		
		Min	Typ	Max	Min	Max	Min	Max	
t _{PLH} t _{PHL}	Propagation Delay C _n to C _{n+x} , C _{n+y} , C _{n+z}	3.0 3.0	6.6 6.8	8.5 9.0	3.0 3.0	12.0 11.0	3.0 3.0	9.5 10.0	ns
t _{PLH} t _{PHL}	Propagation Delay P ₀ , P ₁ , or P ₂ to C _{n+x} , C _{n+y} , or C _{n+z}	2.5 1.5	6.2 3.7	8.0 5.0	2.5 1.0	11.0 7.0	2.5 1.5	9.0 6.0	ns
t _{PLH} t _{PHL}	Propagation Delay G ₀ , G ₁ , or G ₂ to C _{n+x} , C _{n+y} , or C _{n+z}	2.5 1.5	6.5 3.9	8.5 5.2	2.5 1.0	11.0 7.0	2.5 1.5	9.5 6.0	ns
t _{PLH} t _{PHL}	Propagation Delay P ₁ , P ₂ , or P ₃ to G	3.0 3.0	7.9 6.0	10.0 8.0	3.0 2.5	12.0 10.0	3.0 3.0	11.0 9.0	ns
t _{PLH} t _{PHL}	Propagation Delay G _n to G	3.0 3.0	8.3 5.7	10.5 7.5	3.0 2.5	12.0 10.0	3.0 3.0	11.5 8.5	ns
t _{PLH} t _{PHL}	Propagation Delay P _n to P	3.0 2.5	5.7 4.1	7.5 5.5	2.5 2.5	10.0 8.0	3.0 2.5	8.5 6.5	ns

Ordering Information

The device number is used to form part of a simplified purchasing code where the package type and temperature range are defined as follows:

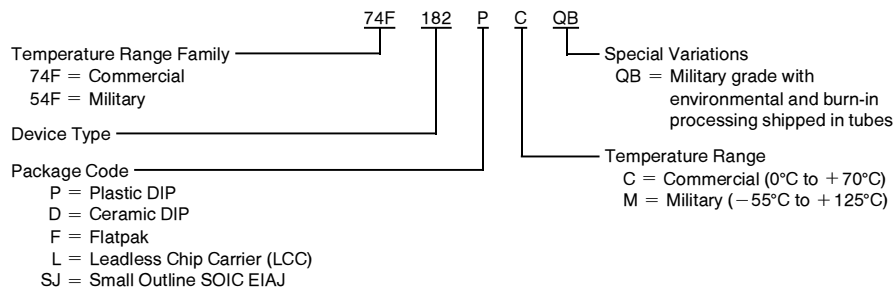

Physical Dimensions inches (millimeters)

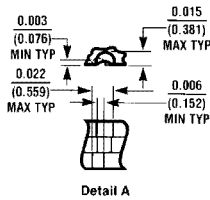
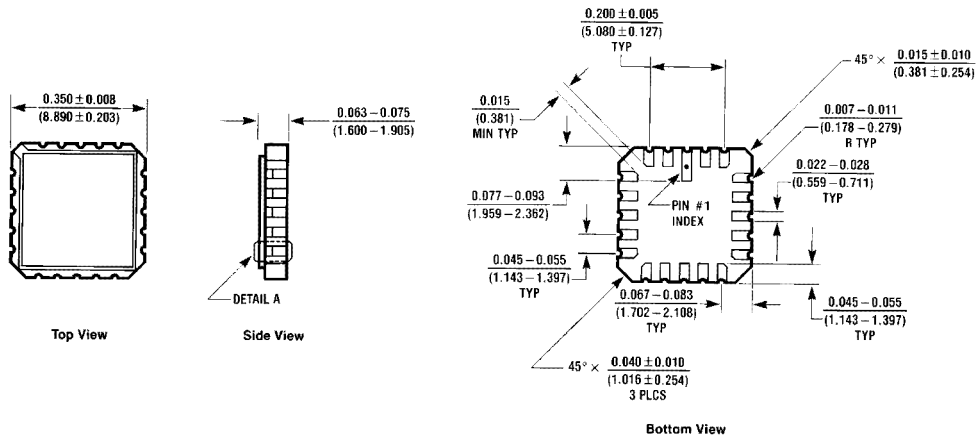

20-Lead Ceramic Leadless Chip Carrier (L)
NS Package Number E20A

E20A (REV D)

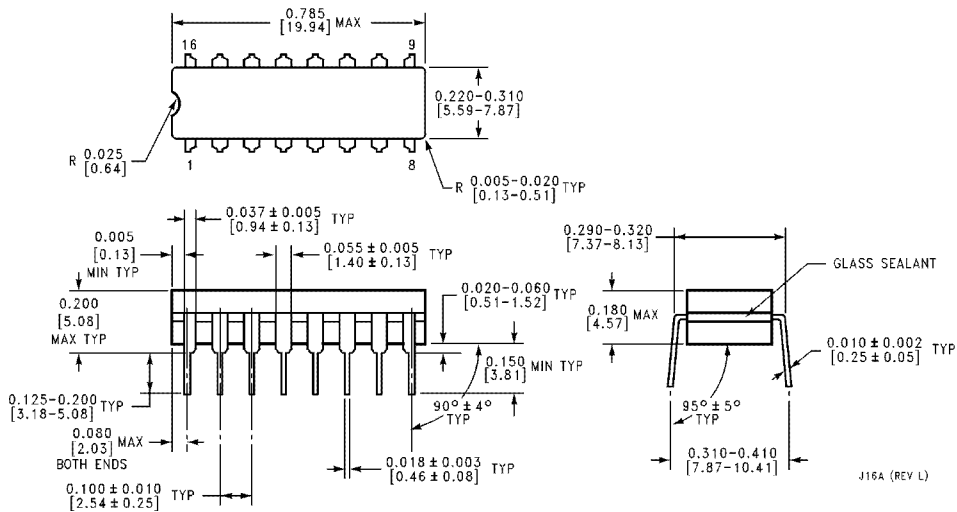

16-Lead Ceramic Dual-In-Line Package (D)
NS Package Number J16A

J16A (REV L)

Physical Dimensions inches (millimeters) (Continued)

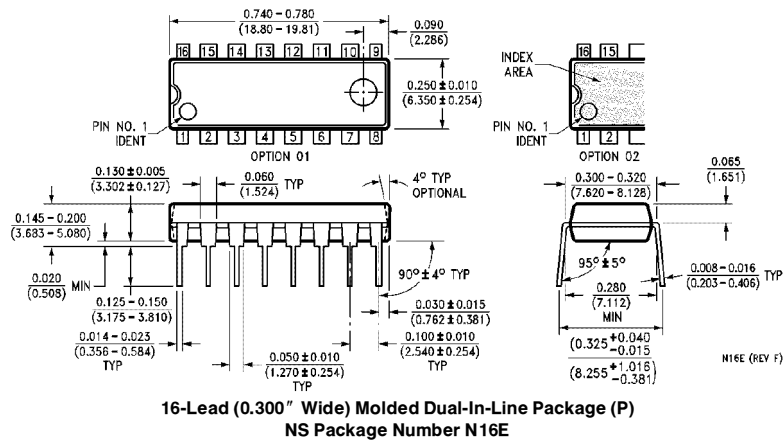
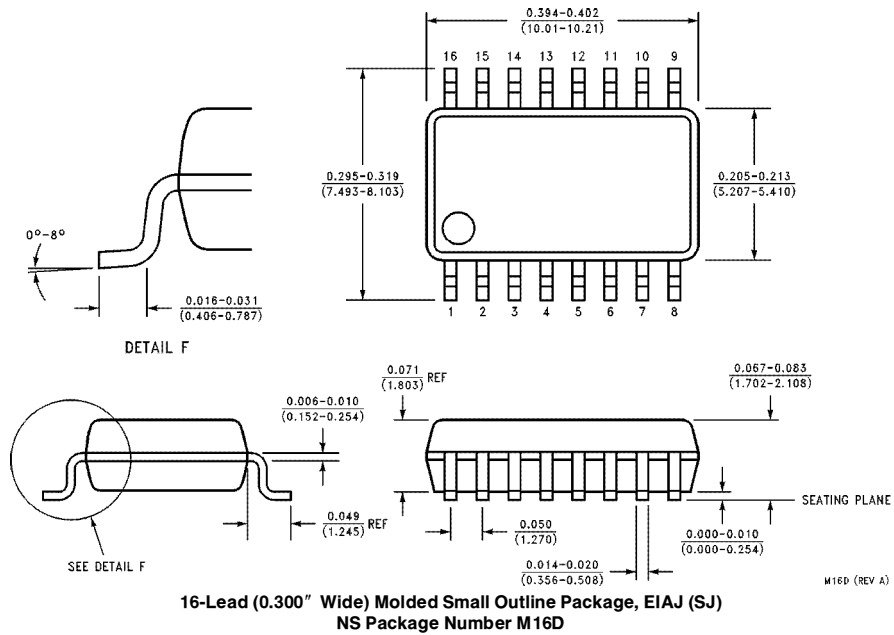

Physical Dimensions inches (millimeters) (Continued)

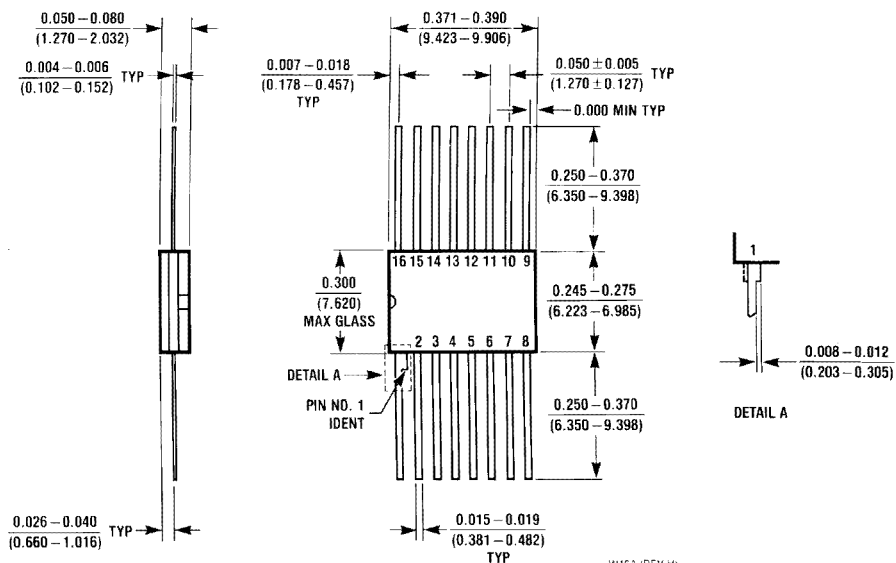

**16-Lead Ceramic Flatpak (F)
NS Package Number W16A**

LIFE SUPPORT POLICY

NATIONAL'S PRODUCTS ARE NOT AUTHORIZED FOR USE AS CRITICAL COMPONENTS IN LIFE SUPPORT DEVICES OR SYSTEMS WITHOUT THE EXPRESS WRITTEN APPROVAL OF THE PRESIDENT OF NATIONAL SEMICONDUCTOR CORPORATION. As used herein:

1. Life support devices or systems are devices or systems which, (a) are intended for surgical implant into the body, or (b) support or sustain life, and whose failure to perform, when properly used in accordance with instructions for use provided in the labeling, can be reasonably expected to result in a significant injury to the user.
2. A critical component is any component of a life support device or system whose failure to perform can be reasonably expected to cause the failure of the life support device or system, or to affect its safety or effectiveness.



National Semiconductor Corporation
1111 West Bardin Road
Arlington, TX 76017
Tel: 1(800) 272-9959
Fax: 1(800) 737-7018

National Semiconductor Europe
Fax: (+49) 0-180-530 85 86
Email: cnjwge@tevm2.nsc.com
Deutsch Tel: (+49) 0-180-530 85 85
English Tel: (+49) 0-180-532 78 32
Français Tel: (+49) 0-180-532 93 58
Italiano Tel: (+49) 0-180-534 16 80

National Semiconductor Hong Kong Ltd.
13th Floor, Straight Block,
Ocean Centre, 5 Canton Rd.
Tsimshatsui, Kowloon
Hong Kong
Tel: (852) 2737-1600
Fax: (852) 2736-9960

National Semiconductor Japan Ltd.
Tel: 81-043-299-2309
Fax: 81-043-299-2408

National does not assume any responsibility for use of any circuitry described, no circuit patent licenses are implied and National reserves the right at any time without notice to change said circuitry and specifications.