

DATA SHEET

~~74F157*~~, **74F157A**, ~~74F158*~~, **74F158A** Data selectors/multiplexers

* Discontinued part. Please see the Discontinued Product List in Section 1, page 21.

Product specification
IC15 Data Handbook

1996 Mar 12

Data selectors/multiplexers

74F157A, 74F158A

74F157A: Quad 2-input data selector/multiplexer, non-inverting

74F158A: Quad 2-input data selector/multiplexer, inverting

DESCRIPTION

The 74F157A is a high speed Quad 2-Input Multiplexer which selects 4 bits of data from one of two sources under the control of a common Select input (S). The Enable input (\bar{E}) is active when Low. When \bar{E} is High, all of the outputs (Yn) are forced Low regardless of all other input conditions.

Moving data from two registers to a common output bus is a common use of the 74F157A. The state of the Select input determines the particular register from which the data comes.

The device is the logic implementation of a 4-pole, 2-position switch where the position of the switch is determined by the logic levels supplied to the Select input.

The 74F158A is similar, but has inverting outputs (\bar{Y}_n).

- Industrial temperature range (-10°C to $+85^{\circ}\text{C}$) available for 74F157A

TYPE	TYPICAL PROPAGATION DELAY	TYPICAL SUPPLY CURRENT (TOTAL)
74F157	4.6ns	15mA
74F157A	4.6ns	15mA
74F158	3.7ns	10mA
74F158A	3.7ns	10mA

ORDERING INFORMATION

DESCRIPTION	ORDER CODE		PKG. DWG. #
	COMMERCIAL RANGE $V_{CC} = 5V \pm 10\%$, $T_{amb} = 0^{\circ}\text{C}$ to $+70^{\circ}\text{C}$	INDUSTRIAL RANGE $V_{CC} = 5V \pm 10\%$, $T_{amb} = -40^{\circ}\text{C}$ to $+85^{\circ}\text{C}$	
16-pin plastic DIP	N74F157AN, N174F158AN	I74F157AN	SOT38-4
16-pin plastic SO	N74F157AD, N74F158AD	I74F157AD	SOT109-1

INPUT AND OUTPUT LOADING AND FAN OUT TABLE

PINS	DESCRIPTION	74F (U.L.) HIGH/LOW	LOAD VALUE HIGH/LOW
I _{1a} , I _{1b} , I _{1c} , I _{1d}	Data inputs	1.0/1.0	20 μ A/0.6mA
S	Select input	1.0/1.0	20 μ A/0.6mA
\bar{E}	Enable input	1.0/1.0	20 μ A/0.6mA
Y _a -Y _d	Data outputs (74F157/74F157A)	50/33	1.0mA/20mA
\bar{Y}_a - \bar{Y}_d	Data outputs (74F158/74F158A)	50/33	1.0mA/20mA

NOTE: One (1.0) FAST unit load is defined as: 20 μ A in the High state and 0.6mA in the Low state.

PIN CONFIGURATIONS, 74F157A

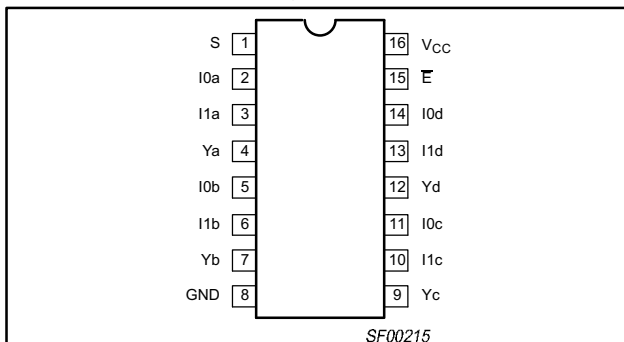

74F158A

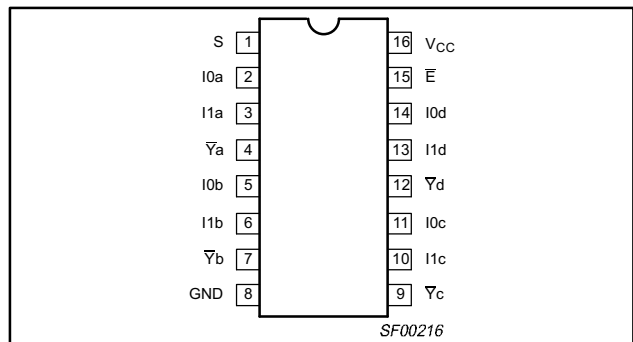

LOGIC SYMBOLS, 74F157A

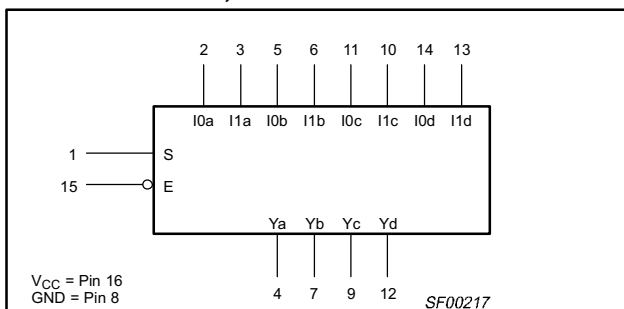

74F158A

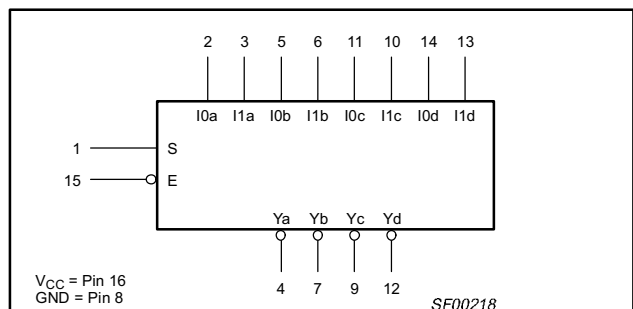

Data selectors/multiplexers

74F157A, 74F158A

IEEE/IEC SYMBOLS, 74F157A

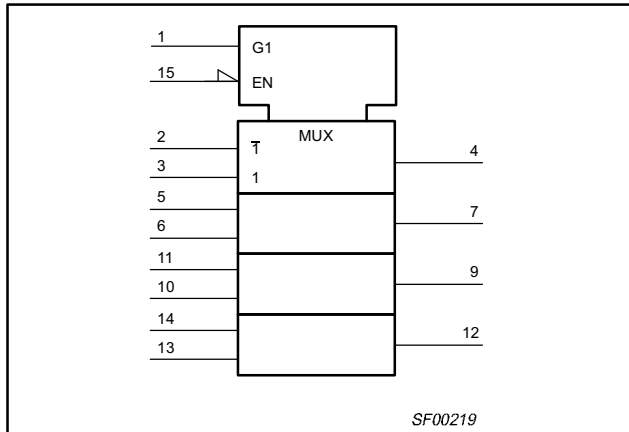

74F158A

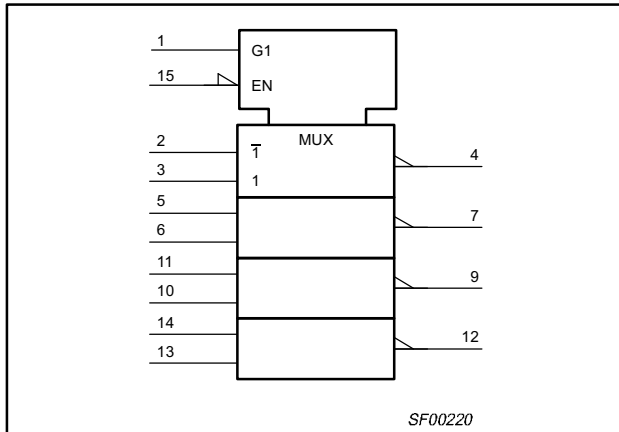

LOGIC DIAGRAM, 74F157A

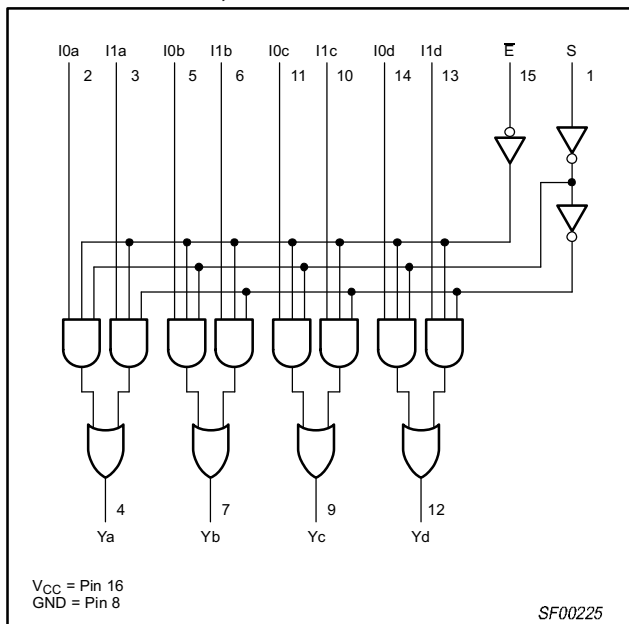

74F158A

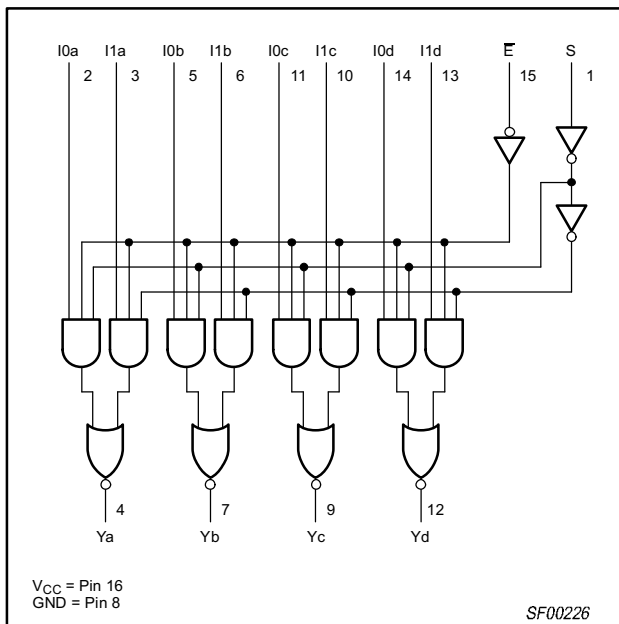

FUNCTION TABLE, 74F157A

INPUTS				OUTPUT
\bar{E}	S	I0n	I1n	Yn
H	X	X	X	L
L	H	X	L	L
L	H	X	H	H
L	L	L	X	L
L	L	H	X	H

H = High voltage level
L = Low voltage level
X = Don't care

74F158A

INPUTS				OUTPUT
\bar{E}	S	I0n	I1n	\bar{Y}_n
H	X	X	X	H
L	L	L	X	H
L	L	H	X	L
L	H	X	L	H
L	H	X	H	L

H = High voltage level
L = Low voltage level
X = Don't care

Data selectors/multiplexers

74F157A, 74F158A

ABSOLUTE MAXIMUM RATINGS

(Operation beyond the limit set forth in this table may impair the useful life of the device. Unless otherwise noted these limits are over the operating free-air temperature range.)

SYMBOL	PARAMETER	RATING	UNIT
V_{CC}	Supply voltage	-0.5 to +7.0	V
V_{IN}	Input voltage	-0.5 to +7.0	V
I_{IN}	Input current	-30 to +5	mA
V_{OUT}	Voltage applied to output in High output state	-0.5 to V_{CC}	V
I_{OUT}	Current applied to output in Low output state	40	mA
T_{amb}	Operating free-air temperature range	Commercial Range	0 to +70
		Industrial Range 74F157A only	-40 to +85
T_{stg}	Storage temperature range	-65 to +150	°C

RECOMMENDED OPERATING CONDITIONS

SYMBOL	PARAMETER	LIMITS			UNIT
		MIN	NOM	MAX	
V_{CC}	Supply voltage	4.5	5.0	5.5	V
V_{IH}	High-level input voltage	2.0			V
V_{IL}	Low-level input voltage			0.8	V
I_{IK}	Input clamp current			-18	mA
I_{OH}	High-level output current			-1	mA
I_{OL}	Low-level output current			20	mA
T_{amb}	Operating free air temperature range	Commercial Range	0	70	
		Industrial Range 74F157A only	-40	85	°C

DC ELECTRICAL CHARACTERISTICS

(Over recommended operating free-air temperature range unless otherwise noted.)

SYMBOL	PARAMETER	TEST CONDITIONS ¹	LIMITS			UNIT	
			MIN	TYP ²	MAX		
V_{OH}	High-level output voltage	$V_{CC} = \text{MIN}, V_{IL} = \text{MAX}$	$\pm 10\%V_{CC}$	2.5		V	
		$V_{IH} = \text{MIN}, I_{OH} = \text{MAX}$	$\pm 5\%V_{CC}$	2.7	3.4		
V_{OL}	Low-level output voltage	$V_{CC} = \text{MIN}, V_{IL} = \text{MAX}$	$\pm 10\%V_{CC}$		0.30	V	
		$V_{IH} = \text{MIN}, I_{OL} = \text{MAX}$	$\pm 5\%V_{CC}$		0.30		
V_{IK}	Input clamp voltage	$V_{CC} = \text{MIN}, I_I = I_{IK}$		-0.73	-1.2	V	
I_I	Input current at maximum input voltage	$V_{CC} = \text{MAX}, V_I = 7.0\text{V}$			100	μA	
I_{IH}	High-level input current	$V_{CC} = \text{MAX}, V_I = 2.7\text{V}$			20	μA	
I_{IL}	Low-level input current	$V_{CC} = \text{MAX}, V_I = 0.5\text{V}$			-0.6	mA	
I_{OS}	Short-circuit output current ³	$V_{CC} = \text{MAX}$		-60	-150	mA	
I_{CC}	Supply current (total) ⁴	74F157A	$V_{CC} = \text{MAX}$		15.0	23.0	mA
		74F158A			14.0	19.0	mA

NOTES:

- For conditions shown as MIN or MAX, use the appropriate value specified under recommended operating conditions for the applicable type.
- All typical values are at $V_{CC} = 5\text{V}$, $T_{amb} = 25^\circ\text{C}$.
- Not more than one output should be shorted at a time. For testing I_{OS} , the use of high-speed test apparatus and/or sample-and-hold techniques are preferable in order to minimize internal heating and more accurately reflect operational values. Otherwise, prolonged shorting of a High output may raise the chip temperature well above normal and thereby cause invalid readings in other parameter tests. In any sequence of parameter tests, I_{OS} tests should be performed last.
- I_{CC} is measured with 4.5V applied to all inputs and all outputs open.

Data selectors/multiplexers

74F157A, 74F158A

AC ELECTRICAL CHARACTERISTICS FOR 74F157A AND 74F158A

SYMBOL	PARAMETER	TEST CONDITION	LIMITS								UNIT
			$V_{CC} = +5.0V$ $T_{amb} = +25^{\circ}C$ $C_L = 50pF$ $R_L = 500\Omega$			$V_{CC} = +5.0V \pm 10\%$ $T_{amb} = 0^{\circ}C \text{ to } +70^{\circ}C$ $C_L = 50pF$ $R_L = 500\Omega$		$V_{CC} = +5.0V \pm 10\%$ $T_{amb} = -40^{\circ}C \text{ to } +85^{\circ}C$ $C_L = 50pF$ $R_L = 500\Omega$			
			MIN	TYP	MAX	MIN	MAX	MIN	MAX		
t_{PLH} t_{PHL}	Propagation delay I_{0n}, I_{1n} to Y_n	74F157A	Waveform 1	3.5	4.5	6.5	3.0	7.0	3.0	7.5	ns
t_{PLH} t_{PHL}	Propagation delay \bar{E} to Y_n		Waveform 3	6.0	7.5	9.0	5.5	10.5	5.5	11.0	
t_{PLH} t_{PHL}	Propagation delay S to Y_n		Waveform 1	5.5	7.5	10.0	5.0	11.0	5.0	11.5	
t_{PLH} t_{PHL}	Propagation delay I_{0n}, I_{1n} to \bar{Y}_n	74F158A	Waveform 2	3.0	4.0	6.0	2.5	7.0	—	—	ns
t_{PLH} t_{PHL}	Propagation delay \bar{E} to \bar{Y}_n		Waveform 4	4.5	5.5	7.0	4.0	7.5	—	—	
t_{PLH} t_{PHL}	Propagation delay S to \bar{Y}_n		Waveform 2	4.5	6.5	8.5	4.0	9.5	—	—	

AC WAVEFORMS

For all waveforms, $V_M = 1.5V$

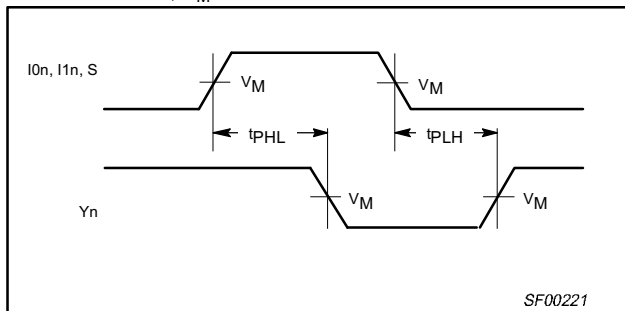

Waveform 1. Propagation Delay for Data and Select to Output

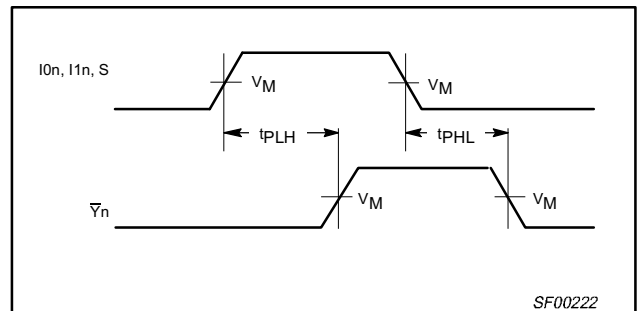

Waveform 2. Propagation Delay for Data and Select to Output

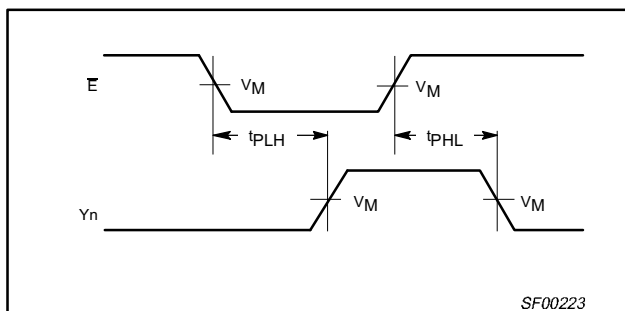

Waveform 3. Propagation Delay for Enable to Output

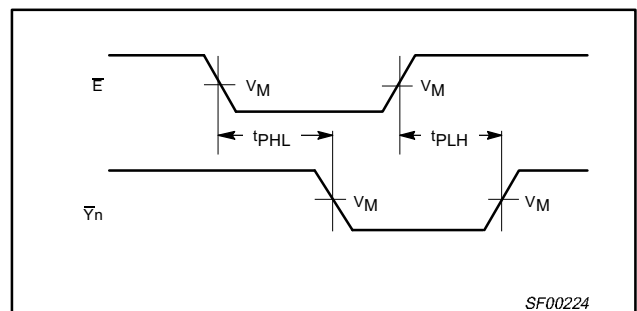

Waveform 4. Propagation Delay for Enable to Output

Data selectors/multiplexers

74F157A, 74F158A

TEST CIRCUIT AND WAVEFORMS

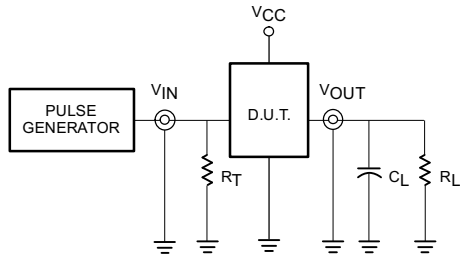

Test Circuit for Totem-Pole Outputs

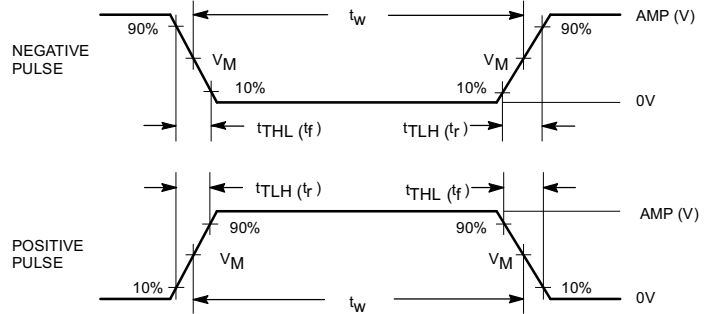

Input Pulse Definition

DEFINITIONS:

- R_L = Load resistor; see AC ELECTRICAL CHARACTERISTICS for value.
- C_L = Load capacitance includes jig and probe capacitance; see AC ELECTRICAL CHARACTERISTICS for value.
- R_T = Termination resistance should be equal to Z_{OUT} of pulse generators.

family	INPUT PULSE REQUIREMENTS					
	amplitude	V_M	rep. rate	t_w	$t_{TLH} (tr)$	$t_{THL} (tr)$
74F	3.0V	1.5V	1MHz	500ns	2.5ns	2.5ns

SF00006

Data selectors/multiplexers

74F157*, 74F157A
74F158*, 74F158A

DIP16: plastic dual in-line package; 16 leads (300 mil)

SOT38-4

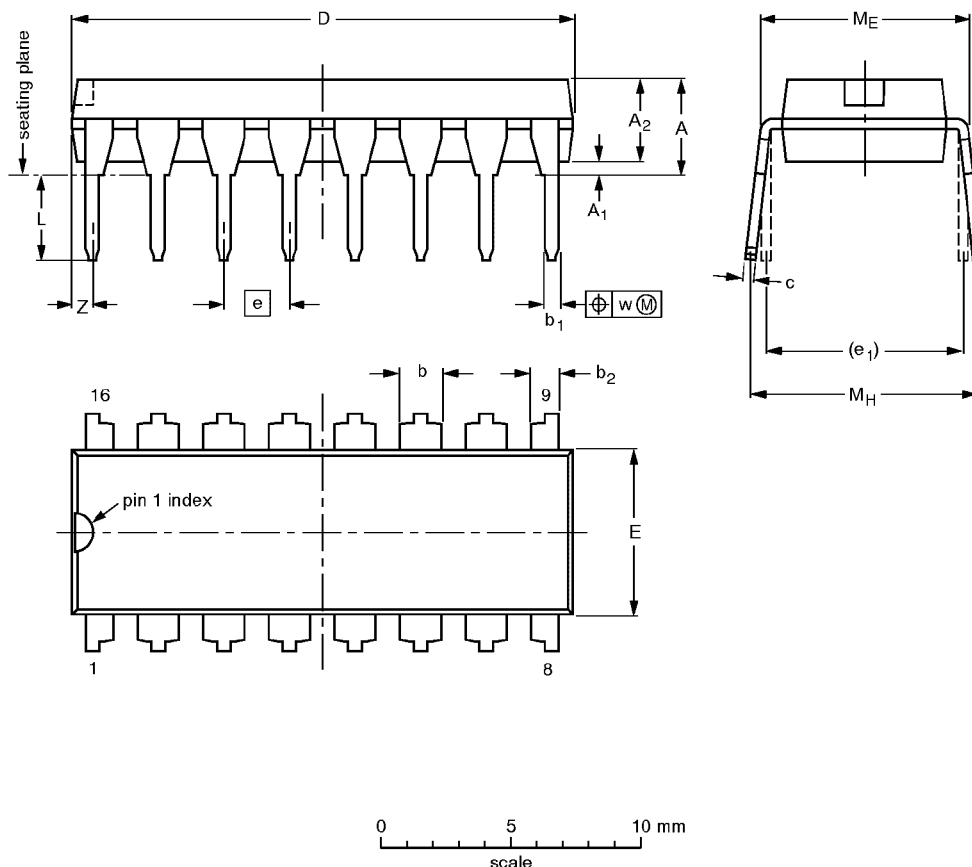

DIMENSIONS (inch dimensions are derived from the original mm dimensions)

UNIT	A max.	A ₁ min.	A ₂ max.	b	b ₁	b ₂	c	D ⁽¹⁾	E ⁽¹⁾	e	e ₁	L	M _E	M _H	w	Z ⁽¹⁾ max.
mm	4.2	0.51	3.2	1.73 1.30	0.53 0.38	1.25 0.85	0.36 0.23	19.50 18.55	6.48 6.20	2.54	7.62	3.60 3.05	8.25 7.80	10.0 8.3	0.254	0.76
inches	0.17	0.020	0.13	0.068 0.051	0.021 0.015	0.049 0.033	0.014 0.009	0.77 0.73	0.26 0.24	0.10	0.30	0.14 0.12	0.32 0.31	0.39 0.33	0.01	0.030

Note

1. Plastic or metal protrusions of 0.25 mm maximum per side are not included.

OUTLINE VERSION	REFERENCES				EUROPEAN PROJECTION	ISSUE DATE
	IEC	JEDEC	EIAJ			
SOT38-4						92-11-17 95-01-14

* Discontinued part. Please see the Discontinued Product List in Section 1, page 21.

Data selectors/multiplexers

74F157*, 74F157A
74F158*, 74F158A

SO16: plastic small outline package; 16 leads; body width 3.9 mm

SOT109-1

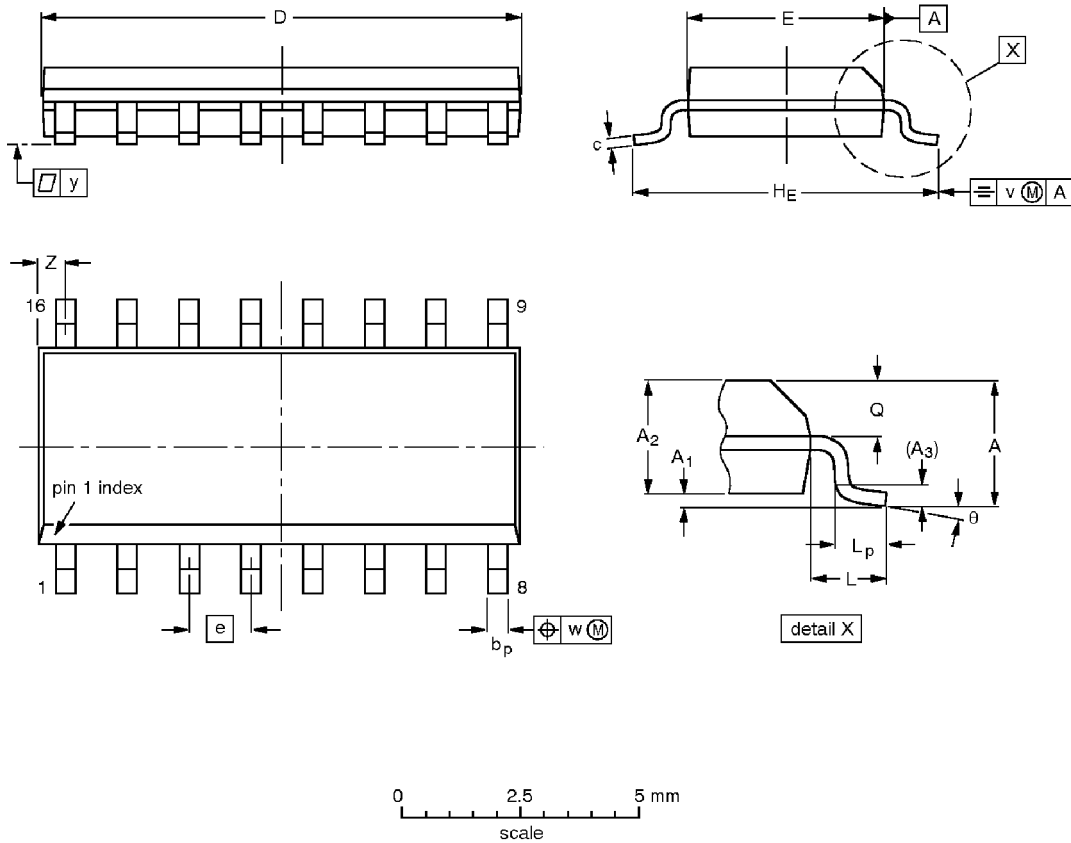

DIMENSIONS (inch dimensions are derived from the original mm dimensions)

UNIT	A max.	A ₁	A ₂	A ₃	b _p	c	D ⁽¹⁾	E ⁽¹⁾	e	H _E	L	L _p	Q	v	w	y	Z ⁽¹⁾	θ
mm	1.75	0.25 0.10	1.45 1.25	0.25	0.49 0.36	0.25 0.19	10.0 9.8	4.0 3.8	1.27	6.2 5.8	1.05	1.0 0.4	0.7 0.6	0.25	0.25	0.1	0.7 0.3	8° 0°
inches	0.069	0.010 0.004	0.057 0.049	0.01	0.019 0.014	0.0100 0.0075	0.39 0.38	0.16 0.15	0.050	0.244 0.228	0.041	0.039 0.016	0.028 0.020	0.01	0.01	0.004	0.028 0.012	

Note

1. Plastic or metal protrusions of 0.15 mm maximum per side are not included.

OUTLINE VERSION	REFERENCES			EUROPEAN PROJECTION	ISSUE DATE
	IEC	JEDEC	EIAJ		
SOT109-1	076E07S	MS-012AC			95-01-23 97-05-22

* Discontinued part. Please see the Discontinued Product List in Section 1, page 21.

Data selectors/multiplexers

~~74F157*~~, 74F157A
~~74F158*~~, 74F158A

NOTES

* *Discontinued part. Please see the Discontinued Product List in Section 1, page 21.*

Data selectors/multiplexers

74F157*, 74F157A,
74F158*, 74F158A

Data sheet status

Data sheet status	Product status	Definition [1]
Objective specification	Development	This data sheet contains the design target or goal specifications for product development. Specification may change in any manner without notice.
Preliminary specification	Qualification	This data sheet contains preliminary data, and supplementary data will be published at a later date. Philips Semiconductors reserves the right to make changes at any time without notice in order to improve design and supply the best possible product.
Product specification	Production	This data sheet contains final specifications. Philips Semiconductors reserves the right to make changes at any time without notice in order to improve design and supply the best possible product.

[1] Please consult the most recently issued datasheet before initiating or completing a design.

Definitions

Short-form specification — The data in a short-form specification is extracted from a full data sheet with the same type number and title. For detailed information see the relevant data sheet or data handbook.

Limiting values definition — Limiting values given are in accordance with the Absolute Maximum Rating System (IEC 134). Stress above one or more of the limiting values may cause permanent damage to the device. These are stress ratings only and operation of the device at these or at any other conditions above those given in the Characteristics sections of the specification is not implied. Exposure to limiting values for extended periods may affect device reliability.

Application information — Applications that are described herein for any of these products are for illustrative purposes only. Philips Semiconductors make no representation or warranty that such applications will be suitable for the specified use without further testing or modification.

Disclaimers

Life support — These products are not designed for use in life support appliances, devices or systems where malfunction of these products can reasonably be expected to result in personal injury. Philips Semiconductors customers using or selling these products for use in such applications do so at their own risk and agree to fully indemnify Philips Semiconductors for any damages resulting from such application.

Right to make changes — Philips Semiconductors reserves the right to make changes, without notice, in the products, including circuits, standard cells, and/or software, described or contained herein in order to improve design and/or performance. Philips Semiconductors assumes no responsibility or liability for the use of any of these products, conveys no license or title under any patent, copyright, or mask work right to these products, and makes no representations or warranties that these products are free from patent, copyright, or mask work right infringement, unless otherwise specified.

Philips Semiconductors
811 East Arques Avenue
P.O. Box 3409
Sunnyvale, California 94088-3409
Telephone 800-234-7381

© Copyright Philips Electronics North America Corporation 1998
All rights reserved. Printed in U.S.A.

print code

Date of release: 10-98

Document order number:

9397-750-05083

* Discontinued part. Please see the Discontinued Product List in Section 1, page 21.

Let's make things better.

Philips
Semiconductors



PHILIPS