

74AC646 • 74ACT646 Octal Transceiver/Register with 3-STATE Outputs

General Description

The AC/ACT646 consist of registered bus transceiver circuits, with outputs, D-type flip-flops and control circuitry providing multiplexed transmission of data directly from the input bus or from the internal storage registers. Data on the A or B bus will be loaded into the respective registers on the LOW-to-HIGH transition of the appropriate clock pin (CPAB or CPBA). The four fundamental data handling functions available are illustrated in Figure 1, Figure 2, Figure 3, and Figure 4.

Features

- Independent registers for A and B buses
- Multiplexed real-time and stored data transfers
- 3-STATE outputs
- 300 mil dual-in-line package
- Outputs source/sink 24 mA
- ACT646 has TTL compatible inputs

Ordering Code:

Order Number	Package Number	Package Description
74AC646SC	M24B	24-Lead Small Outline Integrated Circuit (SOIC), JEDEC MS-013, 0.300" Wide Body
74AC646SPC	N24C	24-Lead Plastic Dual-In-Line Package (PDIP), JEDEC MS-100, 0.300" Wide
74ACT646SPC	N24C	24-Lead Plastic Dual-In-Line Package (PDIP), JEDEC MS-100, 0.300" Wide

Device also available in Tape and Reel. Specify by appending suffix letter "X" to the ordering code.

Logic Symbols

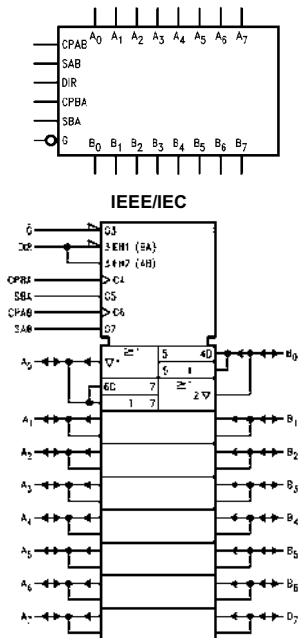

Connection Diagram

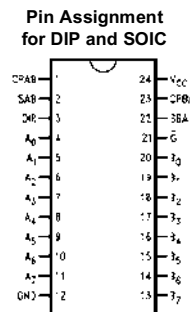

Pin Descriptions

Pin Names	Description
A ₀ -A ₇	Data Register A Inputs
	Data Register A Outputs
B ₀ -B ₇	Data Register B Inputs
	Data Register B Outputs
CPAB, CPBA	Clock Pulse Inputs
SAB, SBA	Transmit/Receive Inputs
\bar{G}	Output Enable Input
DIR	Direction Control Input

FACT™ is a trademark of Fairchild Semiconductor Corporation.

Function Table

Inputs						Data I/O (Note 1)		Function
\overline{G}	DIR	CPAB	CPBA	SAB	SBA	A ₀ –A ₇	B ₀ –B ₇	
H	X	H or L	H or L	X	X			Isolation
H	X	↗	X	X	X	Input	Input	Clock A _n Data into A Register Clock B _n Data into B Register
H	X	X	↗	X	X			
L	H	X	X	L	X			A _n to B _n —Real Time (Transparent Mode)
L	H	↗	X	L	X	Input	Output	Clock A _n Data into A Register
L	H	H or L	X	H	X			A Register to B _n (Stored Mode)
L	H	↗	X	H	X			Clock A _n Data into A Register and Output to B _n
L	L	X	X	X	L			B _n to A _n —Real Time (Transparent Mode)
L	L	X	↗	X	L	Output	Input	Clock B _n Data into B Register
L	L	X	H or L	X	H			B Register to A _n (Stored Mode)
L	L	X	↗	X	H			Clock B _n Data into B Register and Output to A _n

H = HIGH Voltage Level
 L = LOW Voltage Level
 X = Immaterial
 ↗ = LOW-to-HIGH Transition

Note 1: The data output functions may be enabled or disabled by various signals at the \overline{G} and DIR inputs. Data input functions are always enabled; i.e., data at the bus pins will be stored on every LOW-to-HIGH transition of the appropriate clock inputs.

**Real Time Transfer
A-Bus to B-Bus**

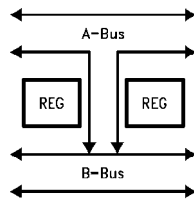

FIGURE 1.

**Real Time Transfer
B-Bus to A-Bus**

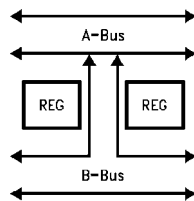

FIGURE 2.

**Storage from
Bus to Register**

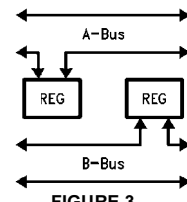

FIGURE 3.

**Transfer from
Register to Bus**

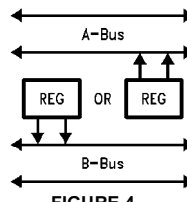

FIGURE 4.

Logic Diagram

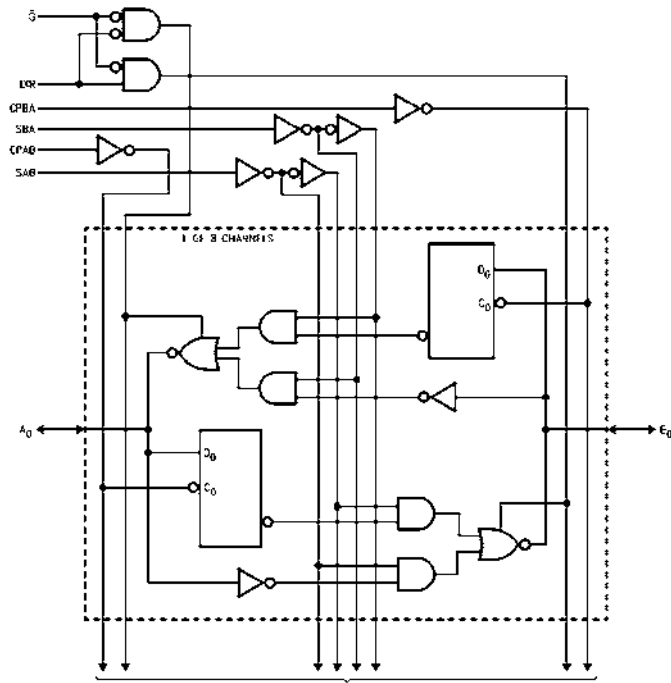

FIG. 7 OTHER CHANNELS

Please note that this diagram is provided only for the understanding of logic operations and should not be used to estimate propagation delays.

Absolute Maximum Ratings (Note 2)

Supply Voltage (V_{CC})	-0.5V to +7.0V
DC Input Diode Current (I_{IK})	
$V_I = -0.5V$	-20 mA
$V_I = V_{CC} + 0.5V$	+20 mA
DC Input Voltage (V_I)	-0.5V to $V_{CC} + 0.5V$
DC Output Diode Current (I_{OK})	
$V_O = -0.5V$	-20 mA
$V_O = V_{CC} + 0.5V$	+20 mA
DC Output Voltage (V_O)	-0.5V to $V_{CC} + 0.5V$
DC Output Source	
or Sink Current (I_O)	± 50 mA
DC V_{CC} or Ground Current	
per Output Pin (I_{CC} or I_{GND})	± 50 mA
Storage Temperature (T_{STG})	-65°C to +150°C
Junction Temperature (T_J)	
PDIP	140°C

Recommended Operating Conditions

Supply Voltage (V_{CC})	
AC	2.0V to 6.0V
ACT	4.5V to 5.5V
Input Voltage (V_I)	0V to V_{CC}
Output Voltage (V_O)	0V to V_{CC}
Operating Temperature (T_A)	-40°C to +85°C
Minimum Input Edge Rate ($\Delta V/\Delta t$)	
AC Devices	
V_{IN} from 30% to 70% of V_{CC}	
V_{CC} @ 3.3V, 4.5V, 5.5V	125 mV/ns
Minimum Input Edge Rate ($\Delta V/\Delta t$)	
ACT Devices	
V_{IN} from 0.8V to 2.0V	
V_{CC} @ 4.5V, 5.5V	125 mV/ns

Note 2: Absolute maximum ratings are those values beyond which damage to the device may occur. The databook specifications should be met, without exception, to ensure that the system design is reliable over its power supply, temperature, and output/input loading variables. Fairchild does not recommend operation of FACT™ circuits outside databook specifications.

DC Electrical Characteristics for AC

Symbol	Parameter	V_{CC} (V)	$T_A = +25^\circ\text{C}$		$T_A = -40^\circ\text{C to } +85^\circ\text{C}$	Units	Conditions
			Typ	Guaranteed Limits			
V_{IH}	Minimum HIGH Level Input Voltage	3.0	1.5	2.1	2.1	V	$V_{OUT} = 0.1V$ or $V_{CC} - 0.1V$
		4.5	2.25	3.15	3.15		
		5.5	2.75	3.85	3.85		
V_{IL}	Maximum LOW Level Input Voltage	3.0	1.5	0.9	0.9	V	$V_{OUT} = 0.1V$ or $V_{CC} - 0.1V$
		4.5	2.25	1.35	1.35		
		5.5	2.75	1.65	1.65		
V_{OH}	Minimum HIGH Level Output Voltage	3.0	2.99	2.9	2.9	V	$I_{OUT} = -50 \mu A$
		4.5	4.49	4.4	4.4		
		5.5	5.49	5.4	5.4		
		3.0		2.56	2.46	V	$V_{IN} = V_{IL}$ or V_{IH} $I_{OH} = -12$ mA $I_{OH} = -24$ mA $I_{OH} = -24$ mA (Note 3)
		4.5		3.86	3.76		
5.5		4.86	4.76				
V_{OL}	Maximum LOW Level Output Voltage	3.0	0.002	0.1	0.1	V	$I_{OUT} = 50 \mu A$
		4.5	0.001	0.1	0.1		
		5.5	0.001	0.1	0.1		
		3.0		0.36	0.44	V	$V_{IN} = V_{IL}$ or V_{IH} $I_{OH} = 12$ mA $I_{OL} = 24$ mA $I_{OH} = 24$ mA (Note 3)
4.5		0.36	0.44				
5.5		0.36	0.44				
I_{IN} (Note 5)	Maximum Input Leakage Current	5.5		± 0.1	± 1.0	μA	$V_I = V_{CC}, GND$
I_{OLD}	Minimum Dynamic	5.5			75	mA	$V_{OLD} = 1.65V$ Max
I_{OHD}	Output Current (Note 4)	5.5			-75	mA	$V_{OHD} = 3.85V$ Min
I_{CC} (Note 5)	Maximum Quiescent Supply Current	5.5		8.0	80.0	μA	$V_{IN} = V_{CC}$ or GND
I_{OZT}	Maximum I/O Leakage Current	5.5		± 0.6	± 6.0	μA	V_I (OE) = V_{IL}, V_{IH} $V_I = V_{CC}, GND$ $V_O = V_{CC}, GND$

Note 3: All outputs loaded; thresholds on input associated with output under test.

Note 4: Maximum test duration 2.0 ms, one output loaded at a time.

Note 5: I_{IN} and I_{CC} @ 3.0V are guaranteed to be less than or equal to the respective limit @ 5.5V V_{CC} .

DC Electrical Characteristics for ACT									
Symbol	Parameter	V _{CC} (V)	T _A = +25°C		T _A = -40°C to +85°C		Units	Conditions	
			Typ	Guaranteed Limits					
V _{IH}	Minimum HIGH Level Input Voltage	4.5	1.5	2.0	2.0		V	V _{OUT} = 0.1V or V _{CC} - 0.1V	
		5.5	1.5	2.0	2.0				
V _{IL}	Maximum LOW Level Input Voltage	4.5	1.5	0.8	0.8		V	V _{OUT} = 0.1V or V _{CC} - 0.1V	
		5.5	1.5	0.8	0.8				
V _{OH}	Minimum HIGH Level Output Voltage	4.5	4.49	4.4	4.4		V	I _{OUT} = -50 μA	
		5.5	5.49	5.4	5.4				
			4.5		3.86	3.76		V	V _{IN} = V _{IL} or V _{IH} I _{OH} = -24 mA I _{OH} = -24 mA (Note 6)
			5.5		4.86	4.76			
V _{OL}	Maximum LOW Level Output Voltage	4.5	0.001	0.1	0.1		V	I _{OUT} = 50 μA	
		5.5	0.001	0.1	0.1				
			4.5		0.36	0.44		V	V _{IN} = V _{IL} or V _{IH} I _{OL} = 24 mA I _{OL} = 24 mA (Note 6)
			5.5		0.36	0.44			
	Maximum Input Leakage Current	5.5		± 0.1	± 1.0		μA	V _I = V _{CC} , GND	
	Maximum I _{CC} /Input	5.5	0.6		1.5		mA	V _I = V _{CC} - 2.1V	
I _{OLD}	Minimum Dynamic	5.5			75		mA	V _{OLD} = 1.65V Max	
I _{OHD}	Output Current (Note 7)	5.5			-75		mA	V _{OHD} = 3.85V Min	
I _{CC}	Maximum Quiescent Supply Current	5.5		8.0	80.0		μA	V _{IN} = V _{CC} or GND	
I _{OZT}	Maximum I/O Leakage Current	5.5		±0.6	±6.0		μA	V _I (OE) = V _{IL} , V _{IH} V _I = V _{CC} , GND V _O = V _{CC} , GND	

Note 6: All outputs loaded; thresholds on input associated with output under test.
Note 7: Maximum test duration 2.0 ms, one output loaded at a time.

AC Electrical Characteristics for AC

Symbol	Parameter	V _{CC} (V) (Note 8)	T _A = +25°C C _L = 50 pF			T _A = -40°C to +85°C C _L = 50 pF		Units
			Min	Typ	Max	Min	Max	
			t _{PLH}	Propagation Delay Clock to Bus	3.3	4.0	10.5	
		5.0	2.5	7.5	12.0	2.0	13.0	
t _{PHL}	Propagation Delay Clock to Bus	3.3	3.0	9.5	14.5	2.5	16.0	ns
		5.0	2.0	6.5	10.5	1.5	11.5	
t _{PLH}	Propagation Delay Bus to Bus	3.3	2.5	7.5	12.0	2.0	13.5	ns
		5.0	1.5	5.0	8.0	1.0	9.0	
t _{PHL}	Propagation Delay Bus to Bus	3.3	1.5	7.5	12.5	1.5	13.5	ns
		5.0	1.5	5.0	9.0	1.0	9.5	
t _{PLH}	Propagation Delay SBA or SAB to A _n or B _n (w/ A _n or B _n HIGH or LOW)	3.3	2.0	8.5	13.5	1.5	15.5	ns
		5.0	1.5	6.0	10.0	1.5	11.0	
t _{PHL}	Propagation Delay SBA or SAB to A _n or B _n (w/ A _n or B _n HIGH or LOW)	3.3	1.5	8.5	13.5	1.5	15.0	ns
		5.0	1.5	6.0	10.0	1.5	11.0	
t _{PZH}	Enable Time G̅ to A _n or B _n	3.3	2.5	7.0	11.5	2.0	12.5	ns
		5.0	1.5	5.0	8.5	1.5	9.0	

AC Electrical Characteristics for AC (Continued)								
Symbol	Parameter	V _{CC} (V) (Note 8)	T _A = +25°C C _L = 50 pF			T _A = -40°C to +85°C C _L = 50 pF		Units
			Min	Typ	Max	Min	Max	
t _{PZL}	Enable Time G to A _n or B _n	3.3	2.5	7.5	12.5	2.0	14.0	ns
		5.0	1.5	5.5	9.0	1.5	10.0	
t _{PHZ}	Disable Time G to A _n or B _n	3.3	3.0	8.0	12.5	2.5	13.5	ns
		5.0	2.0	6.5	10.0	2.0	11.0	
t _{PLZ}	Disable Time G to A _n or B _n	3.3	2.0	7.5	12.0	2.0	13.5	ns
		5.0	1.5	6.0	9.5	1.5	10.5	
t _{PZH}	Enable Time DIR to A _n or B _n	3.3	2.0	6.5	11.0	1.5	12.0	ns
		5.0	1.5	5.0	7.5	1.0	8.5	
t _{PZL}	Enable Time DIR to A _n or B _n	3.3	2.5	7.0	11.5	2.0	13.0	ns
		5.0	1.5	5.0	8.0	1.0	9.0	
t _{PHZ}	Disable Time DIR to A _n or B _n	3.3	2.5	7.5	11.5	1.5	12.5	ns
		5.0	1.5	5.5	9.5	1.5	10.0	
t _{PLZ}	Disable Time DIR to A _n or B _n	3.3	1.5	7.5	12.0	1.5	13.5	ns
		5.0	1.5	5.5	9.5	1.5	10.5	
Note 8: Voltage Range 3.3 is 3.3V ±0.3V Voltage Range 5.0 is 5.0V ±0.5V								
AC Operating Requirements for AC								
Symbol	Parameter	V _{CC} (V) (Note 9)	T _A = +25°C C _L = 50 pF		T _A = -40°C to +85°C C _L = 50 pF		Units	
			Typ	Guaranteed Minimum				
t _S	Setup Time, HIGH or LOW Bus to Clock	3.3	2.0	5.0	5.5		ns	
		5.0	1.5	4.0	4.5			
t _H	Hold Time, HIGH or LOW Bus to Clock	3.3	-1.5	0	0		ns	
		5.0	-0.5	0.5	1.0			
t _W	Clock Pulse Width HIGH or LOW	3.3	2.0	3.5	4.5		ns	
		5.0	2.0	3.5	3.5			
Note 9: Voltage Range 3.3 is 3.3V ±0.3V Voltage Range 5.0 is 5.0V ±0.5V								

AC Electrical Characteristics for ACT								
Symbol	Parameter	V _{CC} (V) (Note 10)	T _A = +25°C C _L = 50 pF			T _A = -40°C to +85°C C _L = 50 pF		Units
			Min	Typ	Max	Min	Max	
t _{PLH}	Propagation Delay Clock to Bus	5.0	3.5	12.0	14.5	3.0	16.0	ns
t _{PHL}	Propagation Delay Clock to Bus	5.0	4.0	12.0	14.5	3.5	16.0	ns
t _{PLH}	Propagation Delay Bus to Bus	5.0	3.0	8.5	10.5	2.5	11.5	ns
t _{PHL}	Propagation Delay Bus to Bus	5.0	2.5	8.5	10.5	2.0	11.5	ns
t _{PLH}	Propagation Delay SBA or SAB to A _n to B _n (w/A _n or B _n HIGH or LOW)	5.0	3.0	9.5	11.5	2.5	12.5	ns
t _{PHL}	Propagation Delay SBA or SAB to A _n to B _n (w/A _n or B _n HIGH or LOW)	5.0	3.0	9.5	11.5	2.5	12.5	ns
t _{PZH}	Enable Time \overline{G} to A _n or B _n	5.0	2.0	9.0	11.0	1.5	12.0	ns
t _{PZL}	Enable Time \overline{G} to A _n or B _n	5.0	3.5	9.0	11.0	3.0	12.0	ns
t _{PHZ}	Disable Time \overline{G} to A _n or B _n	5.0	5.0	10.5	13.0	4.5	14.5	ns
t _{PLZ}	Disable Time \overline{G} to A _n or B _n	5.0	3.5	10.0	12.5	3.0	14.0	ns
t _{PZH}	Enable Time DIR to A _n or B _n	5.0	2.0	6.5	10.5	1.5	11.5	ns
t _{PZL}	Enable Time DIR to A _n or B _n	5.0	3.5	6.5	10.5	3.0	11.5	ns
t _{PHZ}	Disable Time DIR to A _n or B _n	5.0	5.0	8.5	12.5	4.5	13.5	ns
t _{PLZ}	Disable Time DIR to A _n or B _n	5.0	3.5	8.5	12.5	3.0	13.5	ns

Note 10: Voltage Range 5.0 is 5.0V ±0.5V

AC Operating Requirements for ACT						
Symbol	Parameter	V _{CC} (V) (Note 11)	T _A = +25°C C _L = 50 pF		T _A = -40°C to +85°C C _L = 50 pF	Units
			Typ	Guaranteed Minimum		
t _S	Setup Time, HIGH or LOW BUS to Clock	5.0	2.5	7.0	8.0	ns
t _H	Hold Time, HIGH or LOW Bus to Clock	5.0	0	2.5	2.5	ns
t _W	Clock Pulse Width HIGH or LOW	5.0	4.5	7.0	8.0	ns
Note 11: Voltage Range 5.0 is 5.0V ±0.5V						
Capacitance						
Symbol	Parameter	Typ	Units	Conditions		
C _{IN}	Input Capacitance	4.5	pF	V _{CC} = OPEN		
C _{I/O}	Input/Output Capacitance	15.0	pF	V _{CC} = 5.0V		
C _{PD}	Power Dissipation Capacitance	60.0	pF	V _{CC} = 5.0V		

Physical Dimensions inches (millimeters) unless otherwise noted

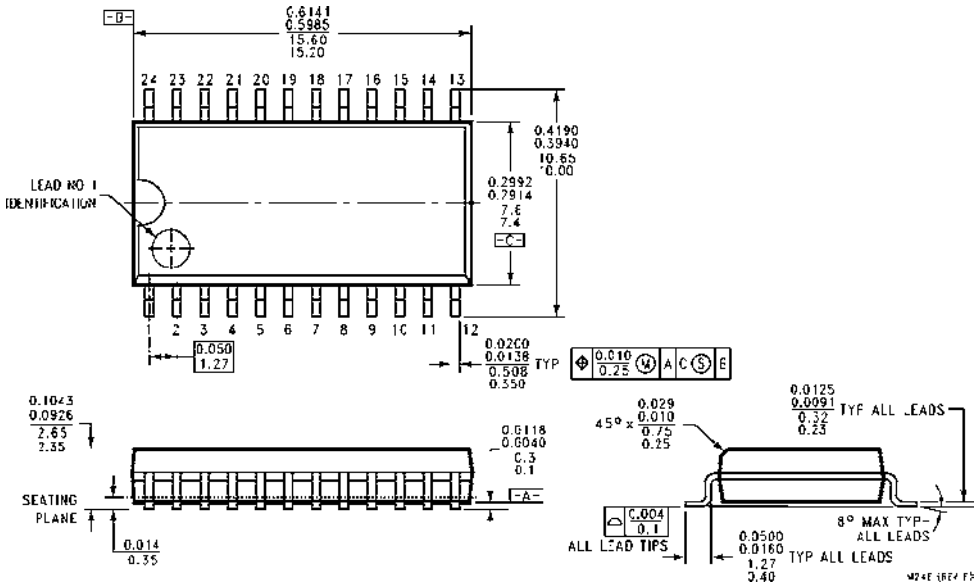

24-Lead Small Outline Integrated Circuit (SOIC), JEDEC MS-013, 0.300" Wide Body
Package Number M24B

