

SN54166, SN54LS166A, SN74166, SN74LS166A PARALLEL-LOAD 8-BIT SHIFT REGISTERS

OCTOBER 1976 REVISED MARCH 1988

- Synchronous Load
- Direct Overriding Clear
- Parallel to Serial Conversion

SN54166, SN54LS166A . . . J OR W PACKAGE
SN74166 . . . N PACKAGE
SN74LS166A . . . D OR N PACKAGE
(TOP VIEW)

TYPE	TYPICAL	MAXIMUM	TYPICAL
	CLOCK FREQUENCY		POWER DISSIPATION
'166	35 MHz		360 mW
'LS166A	35 MHz		100 mW

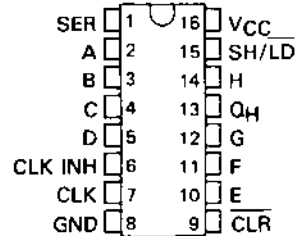

description

The '166 and 'LS166A 8-bit shift registers are compatible with most other TTL logic families. All '166 and 'LS166A inputs are buffered to lower the drive requirements to one Series 54/74 or Series 54LS/74LS standard load, respectively. Input clamping diodes minimize switching transients and simplify system design.

These parallel-in or serial-in, serial-out shift registers have a complexity of 77 equivalent gates on a monolithic chip. They feature gated clock inputs and an overriding clear input. The parallel-in or serial-in modes are established by the shift/load input. When high, this input enables the serial data input and couples the eight flip-flops for serial shifting with each clock pulse. When low, the parallel (broadside) data inputs are enabled and synchronous loading occurs on the next clock pulse. During parallel loading, serial data flow is inhibited. Clocking is accomplished on the low-to-high-level edge of the clock pulse through a two-input positive NOR gate permitting one input to be used as a clock-enable or clock-inhibit function. Holding either of the clock inputs high inhibits clocking; holding either low enables the other clock input. This, of course, allows the system clock to be free-running and the register can be stopped on command with the other clock input. The clock inhibit input should be changed to the high level only while the clock input is high. A buffered, direct clear input overrides all other inputs, including the clock, and sets all flip-flops to zero.

SN54LS166A . . . FK PACKAGE
(TOP VIEW)

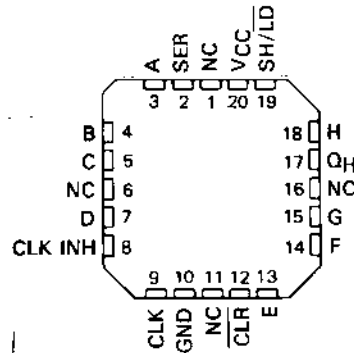

NC - No internal connection

logic symbol†

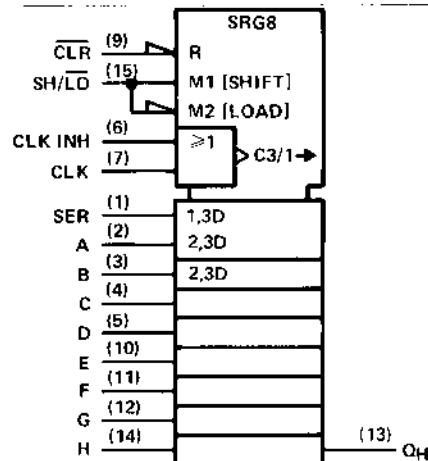

† This symbol is in accordance with ANSI/IEEE Std 91-1984 and IEC Publication 617-12.

Pin numbers shown are for D, J, N, and W packages.

FUNCTION TABLE

CLEAR	SHIFT/ LOAD	INPUTS			SERIAL	PARALLEL A . . . H	INTERNAL OUTPUTS		OUTPUT QH
		CLOCK INHIBIT	CLOCK				QA	QB	
L	X	X	X	X	X	L	L	L	
H	X	L	L	X	X	QA0	QB0	QH0	
H	L	L	↑	X	a . . . h	a	b	h	
H	H	L	↑	H	X	H	QA _n	QG _n	
H	H	L	↑	L	X	L	QA _n	QG _n	
H	X	H	↑	X	X	QA0	QB0	QH0	

PRODUCTION DATA documents contain information current as of publication date. Products conform to specifications per the terms of Texas Instruments standard warranty. Production processing does not necessarily include testing of all parameters.

TEXAS
INSTRUMENTS

POST OFFICE BOX 655012 • DALLAS, TEXAS 75265

2-529

2

TTL Devices

SN54166, SN54LS166A, SN74166, SN74LS166A
PARALLEL-LOAD 8-BIT SHIFT REGISTERS

typical clear, shift, load, inhibit, and shift sequences

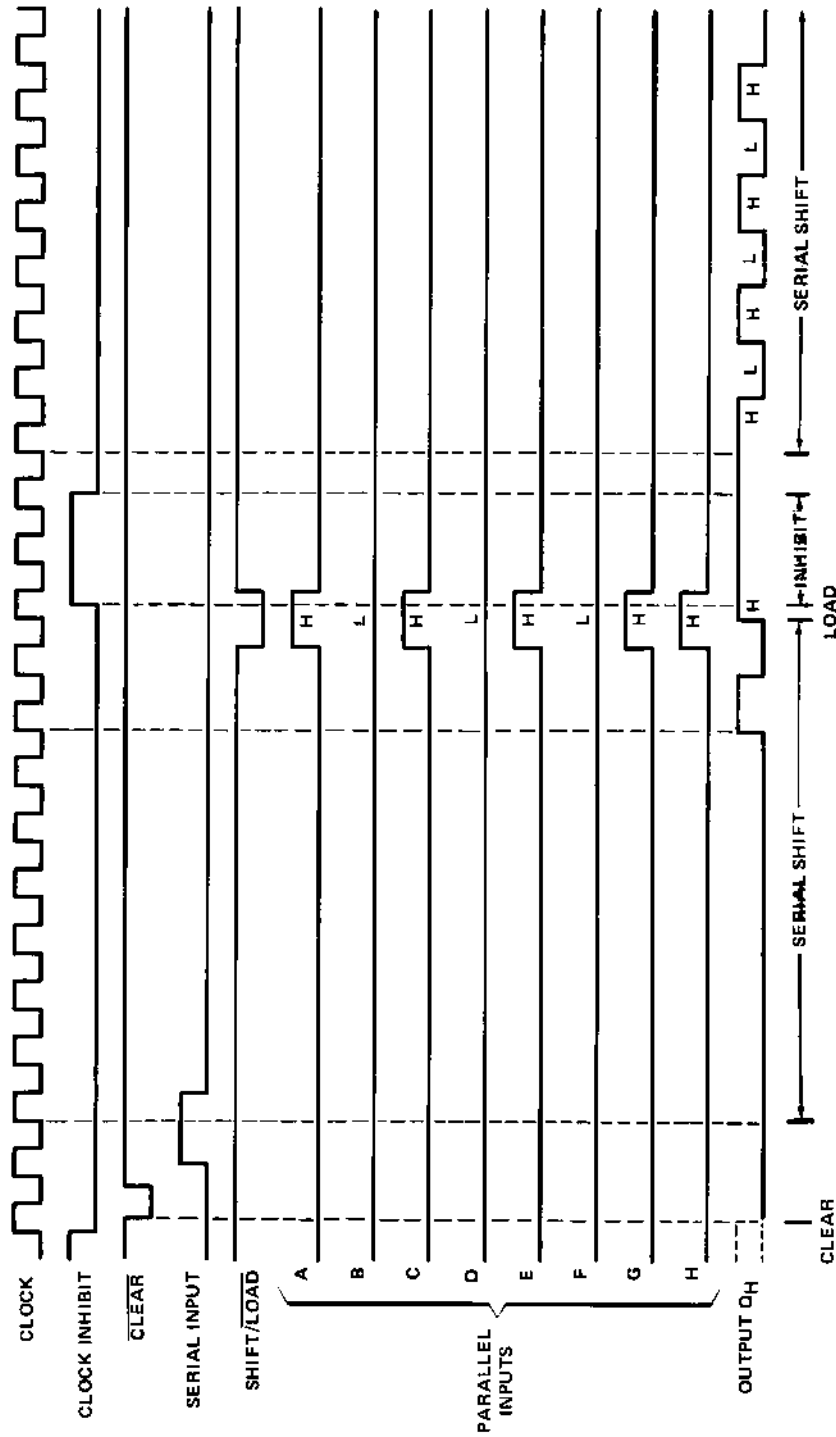

**SN54166, SN54LS166A, SN74166, SN74LS166A
PARALLEL-LOAD 8-BIT SHIFT REGISTERS**

schematics of inputs and outputs

'166

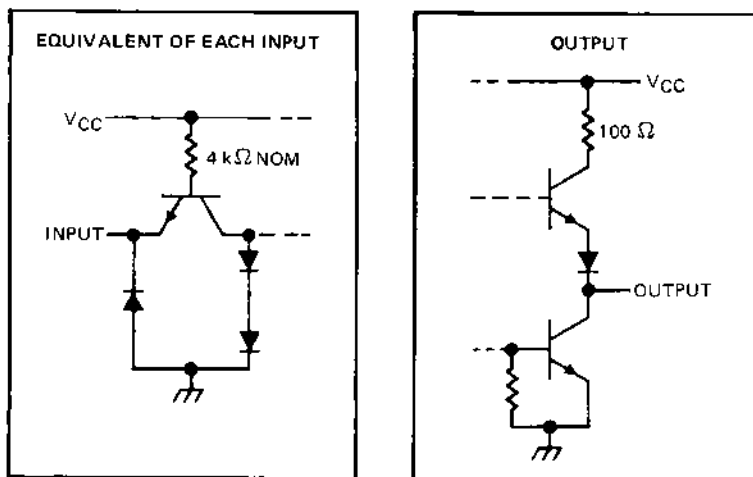

'LS166A

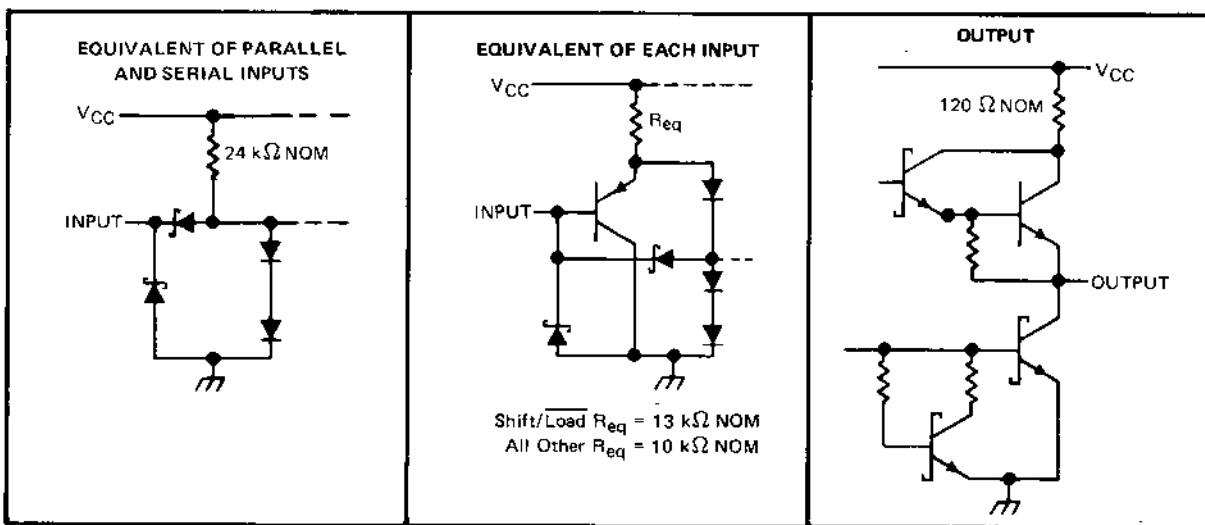

2

TTL Devices

SN54166, SN54LS166A, SN74166, SN74LS166A
PARALLEL-LOAD 8-BIT SHIFT REGISTERS

logic diagram (positive logic)

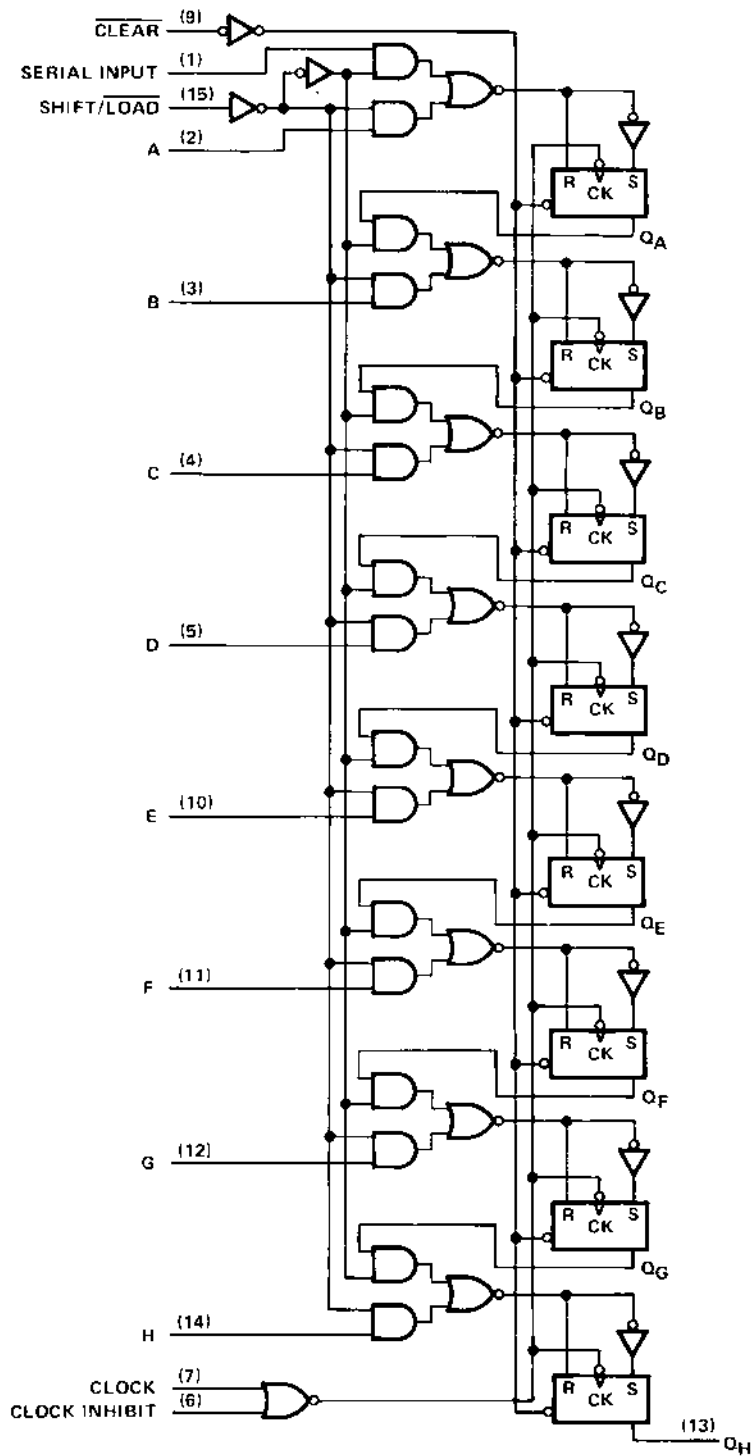

Pin numbers shown are for D, J, N, and W packages.

2

TTL Devices

SN54166, SN74166 PARALLEL-LOAD 8-BIT SHIFT REGISTERS

absolute maximum ratings over operating free-air temperature range (unless otherwise noted)

Supply voltage, V_{CC} (see Note 1)	7	V
Input voltage	5.5	V
Operating free-air temperature range: SN54166 (see Note 2)	-55	°C to 125
SN74166	0	°C to 70
Storage temperature range	-65	°C to 150

recommended operating conditions

	SN54166			SN74166			UNIT
	MIN	NOM	MAX	MIN	NOM	MAX	
Supply voltage, V_{CC}	4.5	5	5.5	4.75	5	5.25	V
High-level output current, I_{OH}			-800			-800	μ A
Low-level output current, I_{OL}			16			16	mA
Clock frequency, f_{clock}	0		25	0		25	MHz
Width of clock or clear pulse, t_w (see Figure 1)	20			20			ns
Mode-control setup time, t_{su}	30			30			ns
Data setup time, t_{su} (see Figure 1)	20			20			ns
Hold time at any input, t_h (see Figure 1)	0			0			ns
Operating free-air temperature, T_A (see Note 2)	-55		125	0		70	C

electrical characteristics over recommended operating free-air temperature range (unless otherwise noted)

PARAMETER	TEST CONDITIONS [†]	SN54166			SN74166			UNIT
		MIN	TYP [‡]	MAX	MIN	TYP [‡]	MAX	
V_{IH} High-level input voltage		2			2			V
V_{IL} Low-level input voltage				0.8			0.8	V
V_{IK} Input clamp voltage	$V_{CC} = \text{MIN}, I_I = -12 \text{ mA}$			-1.5			-1.5	V
V_{OH} High-level output voltage	$V_{CC} = \text{MIN}, V_{IH} = 2 \text{ V}, V_{IL} = 0.8 \text{ V}, I_{OH} = -800 \mu\text{A}$	2.4	3.4		2.4	3.4		V
V_{OL} Low-level output voltage	$V_{CC} = \text{MIN}, V_{IH} = 2 \text{ V}, V_{IL} = 0.8 \text{ V}, I_{OL} = 16 \text{ mA}$	0.2	0.4		0.2	0.4		V
I_I Input current at maximum input voltage	$V_{CC} = \text{MAX}, V_I = 5.5 \text{ V}$			1			1	mA
I_{IH} High-level input current	$V_{CC} = \text{MAX}, V_I = 2.4 \text{ V}$			40			40	μ A
I_{IL} Low-level input current	$V_{CC} = \text{MAX}, V_I = 0.4 \text{ V}$			-1.6			-1.6	mA
I_{OS} Short-circuit output current [§]	$V_{CC} = \text{MAX}$	-20		-57	-18		-57	mA
I_{CC} Supply current	$V_{CC} = \text{MAX},$ See Note 3	90	127		90	127		mA

[†] For conditions shown as MIN or MAX, use the appropriate value specified under recommended operating conditions.

[‡] All typical values are at $V_{CC} = 5 \text{ V}, T_A = 25^\circ \text{C}$.

[§] Not more than one output should be shorted at a time.

NOTES: 1. Voltage values are with respect to network ground terminal.

2. An SN54166 in the W package operating at free air temperatures above 113°C requires a heat-sink that provides a thermal resistance from case to free air, $R_{\theta CA}$, of not more than 48°C/W .

3. With all outputs open, 4.5 V applied to the serial input, all other inputs except the clock grounded, I_{CC} is measured after a momentary ground, then 4.5 V, is applied to the clock.

switching characteristics, $V_{CC} = 5 \text{ V}, T_A = 25^\circ \text{C}$

PARAMETER	TEST CONDITIONS	MIN	TYP	MAX	UNIT
f_{max} Maximum clock frequency		25	35		MHz
t_{PHL} Propagation delay time, high-to-low-level output from clear	$C_L = 15 \text{ pF}, R_L = 400 \Omega,$ See Figure 1		23	35	ns
t_{PHL} Propagation delay time, high-to-low level output from clock			20	30	ns
t_{PLH} Propagation delay time, low-to-high-level output from clock			17	26	ns

2

TTL Devices

SN54LS166A, SN74LS166A PARALLEL-LOAD 8-BIT SHIFT REGISTERS

absolute maximum ratings over operating free-air temperature range (unless otherwise noted)

Supply voltage, V_{CC} (see Note 1)	7 V
Input voltage	7 V
Operating free-air temperature range: SN54LS166A	-55°C to 125°C
SN74LS166A	0°C to 70°C
Storage temperature range	-65°C to 150°C

NOTE 1: Voltage values are with respect to network ground terminal.

recommended operating conditions

		SN54LS166A			SN74LS166A			UNIT		
		MIN	TYP	MAX	MIN	TYP	MAX			
V_{CC}	Supply voltage	4.5	5	5.5	4.75	5	5.25	V		
V_{IH}	High-level input voltage	2			2			V		
V_{IL}	Low-level input voltage	0.7			0.8			V		
I_{OH}	High-level output current	-0.4			-0.4			mA		
I_{OL}	Low-level output current	4			8			mA		
f_{clock}	Clock frequency	0			25			MHz		
t_w	Width of clear pulse (See Figure 1)	20			20			ns		
t_w	Width of clock pulse (See Figure 1)	25			25					
t_{su}	Mode-control setup time	30			30			ns		
t_{su}	Data setup time (See Figure 1)	20			20			ns		
t_h	Hold time at any input (See Figure 1 and Note 4)	0			0			ns		
T_A	Operating free air temperature	-55			125			0	70	°C

NOTE 4: The hold time limit of 0 ns applies only if the rise time is less than or equal to 10 ns.

electrical characteristics over recommended operating free-air temperature range (unless otherwise noted)

PARAMETER	TEST CONDITIONS†	SN54LS166A			SN74LS166A			UNIT
		MIN	TYP‡	MAX	MIN	TYP‡	MAX	
V_{IK}	$V_{CC} = \text{MIN}$, $I_I = -18 \text{ mA}$	-1.5			-1.5			V
V_{OH}	$V_{CC} = \text{MIN}$, $V_{IH} = 2 \text{ V}$, $V_{IL} = \text{MAX}$, $I_{OH} = -0.4 \text{ mA}$	2.5	3.4		2.7	3.4		V
V_{OL}	$V_{CC} = \text{MIN}$, $V_{IH} = 2 \text{ V}$, $V_{IL} = \text{MAX}$	0.25		0.4	0.25		0.4	V
					0.35		0.5	
I_I	$V_{CC} = \text{MAX}$, $V_I = 7 \text{ V}$	0.1			0.1			mA
I_{IH}	$V_{CC} = \text{MAX}$, $V_I = 2.7 \text{ V}$	20			20			µA
I_{IL}	$V_{CC} = \text{MAX}$, $V_I = 0.4 \text{ V}$	-0.4			-0.4			mA
$I_{OS}§$	$V_{CC} = \text{MAX}$	-20	-100		-20	-100		mA
I_{CC}	$V_{CC} = \text{MAX}$, See Note 5	20		32	20		32	mA

†For conditions shown as MIN or MAX, use the appropriate value specified under recommended operating conditions.

‡All typical values are at $V_{CC} = 5 \text{ V}$, $T_A = 25^\circ\text{C}$.

§Not more than one output should be shorted at a time, and duration for short-circuit should not exceed one second.

NOTE 5: With all outputs open, 4.5 V applied to the serial input and all other inputs except the clock grounded, I_{CC} is measured after a momentary ground, than 4.5 V, is applied to clock.

switching characteristics, $V_{CC} = 5 \text{ V}$, $T_A = 25^\circ\text{C}$

PARAMETER	TEST CONDITIONS	MIN	TYP	MAX	UNIT
f_{max}	Maximum clock frequency	25	35		MHz
t_{PHL}	Propagation delay time, high-to-low-level output from clear	19		30	ns
t_{PHL}	Propagation delay time, high-to-low-level output from clock	7	14	25	ns
t_{PLH}	Propagation delay time, low-to-high-level output from clock	5	11	20	ns

$C_L = 15 \text{ pF}$, $R_L = 2 \text{ k}\Omega$,
See Figure 1

SN54166, SN54LS166A, SN74166, SN74LS166A
PARALLEL-LOAD 8-BIT SHIFT REGISTERS

PARAMETER MEASUREMENT INFORMATION

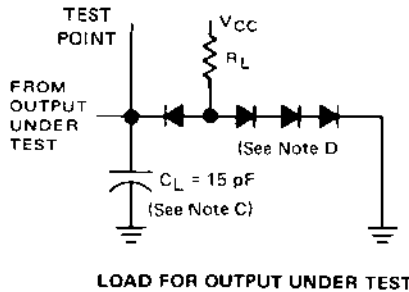

TEST TABLE FOR SYNCHRONOUS INPUTS

DATA INPUT FOR TEST	SHIFT/LOAD	OUTPUT TESTED (SEE NOTE F)
H	0 V	Q_H at t_{n+1}
Serial Input	4.5 V	Q_H at t_{n+8}

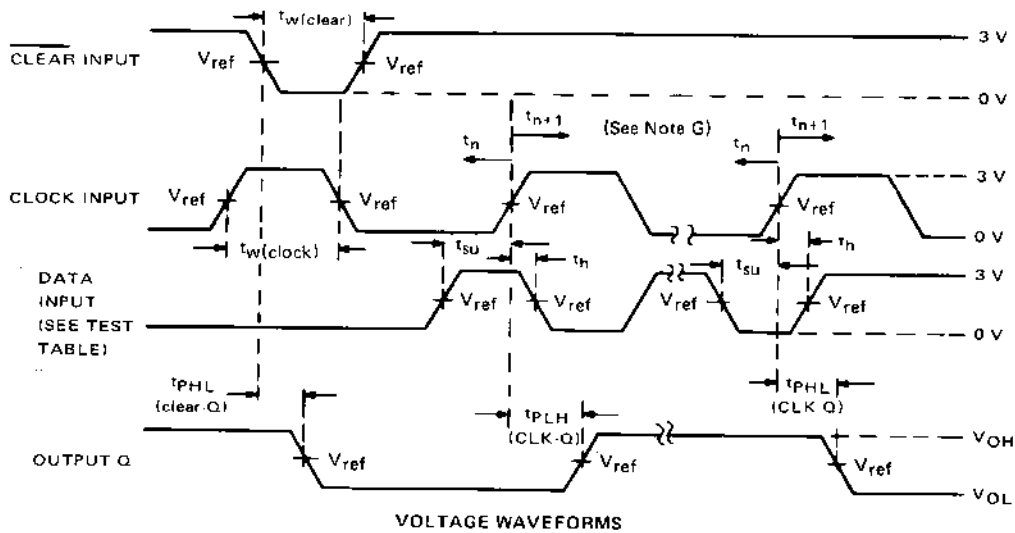

- NOTE: A. All pulse generators have the following characteristics: $Z_{out} \approx 50 \Omega$; for '166, $t_r \leq 7 \text{ ns}$ and $t_f \leq 7 \text{ ns}$; for 'LS166A, $t_r \leq 15 \text{ ns}$ and $t_f \leq 6 \text{ ns}$.
- B. The clock pulse has the following characteristics: $t_w(\text{clock}) \leq 20 \text{ ns}$ and $\text{PRR} = 1 \text{ MHz}$. The clear pulse has the following characteristics: $t_w(\text{clear}) \leq 20 \text{ ns}$ and $t_{hold} = 0 \text{ ns}$. When testing f_{max} , vary the clock PRR.
- C. C_L includes probe and jig capacitance.
- D. All diodes are 1N3064, 1N916, or equivalent.
- E. A clear pulse is applied prior to each test.
- F. Propagation delay times (t_{PLH} and t_{PHL}) are measured at t_{n+1} . Proper shifting of data is verified at t_{n+8} with a functional test.
- G. t_n = bit time before clocking transition
 t_{n+1} = bit time after one clocking transition
 t_{n+8} = bit time after eight clocking transitions
- H. For '166 $V_{ref} = 1.5 \text{ V}$; for 'LS166A $V_{ref} = 1.3 \text{ V}$.

FIGURE 1

PACKAGING INFORMATION

Orderable Device	Status ⁽¹⁾	Package Type	Package Drawing	Pins	Package Qty	Eco Plan ⁽²⁾	Lead/Ball Finish	MSL Peak Temp ⁽³⁾
5962-9558301QEA	ACTIVE	CDIP	J	16	1	TBD	Call TI	Level-NC-NC-NC
5962-9558301QFA	ACTIVE	CFP	W	16	1	TBD	Call TI	Level-NC-NC-NC
5962-9558301QFA	ACTIVE	CFP	W	16	1	TBD	Call TI	Level-NC-NC-NC
8001701EA	ACTIVE	CDIP	J	16	1	TBD	Call TI	Level-NC-NC-NC
8001701EA	ACTIVE	CDIP	J	16	1	TBD	Call TI	Level-NC-NC-NC
8001701FA	ACTIVE	CFP	W	16	1	TBD	Call TI	Level-NC-NC-NC
8001701FA	ACTIVE	CFP	W	16	1	TBD	Call TI	Level-NC-NC-NC
JM38510/30609B2A	ACTIVE	LCCC	FK	20	1	TBD	Call TI	Level-NC-NC-NC
JM38510/30609B2A	ACTIVE	LCCC	FK	20	1	TBD	Call TI	Level-NC-NC-NC
JM38510/30609BEA	ACTIVE	CDIP	J	16	1	TBD	Call TI	Level-NC-NC-NC
JM38510/30609BEA	ACTIVE	CDIP	J	16	1	TBD	Call TI	Level-NC-NC-NC
JM38510/30609BFA	ACTIVE	CFP	W	16	1	TBD	Call TI	Level-NC-NC-NC
JM38510/30609BFA	ACTIVE	CFP	W	16	1	TBD	Call TI	Level-NC-NC-NC
SN54166J	ACTIVE	CDIP	J	16	1	TBD	Call TI	Level-NC-NC-NC
SN54166J	ACTIVE	CDIP	J	16	1	TBD	Call TI	Level-NC-NC-NC
SN54LS166AJ	ACTIVE	CDIP	J	16	1	TBD	Call TI	Level-NC-NC-NC
SN54LS166AJ	ACTIVE	CDIP	J	16	1	TBD	Call TI	Level-NC-NC-NC
SN74166N	OBSOLETE	PDIP	N	16		TBD	Call TI	Call TI
SN74166N	OBSOLETE	PDIP	N	16		TBD	Call TI	Call TI
SN74166N3	OBSOLETE	PDIP	N	16		TBD	Call TI	Call TI
SN74166N3	OBSOLETE	PDIP	N	16		TBD	Call TI	Call TI
SN74LS166AD	ACTIVE	SOIC	D	16	40	Green (RoHS & no Sb/Br)	CU NIPDAU	Level-1-260C-UNLIM
SN74LS166AD	ACTIVE	SOIC	D	16	40	Green (RoHS & no Sb/Br)	CU NIPDAU	Level-1-260C-UNLIM
SN74LS166ADE4	ACTIVE	SOIC	D	16	40	Green (RoHS & no Sb/Br)	CU NIPDAU	Level-1-260C-UNLIM
SN74LS166ADE4	ACTIVE	SOIC	D	16	40	Green (RoHS & no Sb/Br)	CU NIPDAU	Level-1-260C-UNLIM
SN74LS166ADR	ACTIVE	SOIC	D	16	2500	Green (RoHS & no Sb/Br)	CU NIPDAU	Level-1-260C-UNLIM
SN74LS166ADR	ACTIVE	SOIC	D	16	2500	Green (RoHS & no Sb/Br)	CU NIPDAU	Level-1-260C-UNLIM
SN74LS166ADRE4	ACTIVE	SOIC	D	16	2500	Green (RoHS & no Sb/Br)	CU NIPDAU	Level-1-260C-UNLIM
SN74LS166ADRE4	ACTIVE	SOIC	D	16	2500	Green (RoHS & no Sb/Br)	CU NIPDAU	Level-1-260C-UNLIM
SN74LS166AJ	OBSOLETE	CDIP	J	16		TBD	Call TI	Call TI
SN74LS166AJ	OBSOLETE	CDIP	J	16		TBD	Call TI	Call TI
SN74LS166AN	ACTIVE	PDIP	N	16	25	Pb-Free (RoHS)	CU NIPDAU	Level-NC-NC-NC
SN74LS166AN	ACTIVE	PDIP	N	16	25	Pb-Free (RoHS)	CU NIPDAU	Level-NC-NC-NC
SN74LS166AN3	OBSOLETE	PDIP	N	16		TBD	Call TI	Call TI
SN74LS166AN3	OBSOLETE	PDIP	N	16		TBD	Call TI	Call TI

Orderable Device	Status ⁽¹⁾	Package Type	Package Drawing	Pins	Package Qty	Eco Plan ⁽²⁾	Lead/Ball Finish	MSL Peak Temp ⁽³⁾
SN74LS166ANSR	ACTIVE	SO	NS	16	2000	Green (RoHS & no Sb/Br)	CU NIPDAU	Level-1-260C-UNLIM
SN74LS166ANSR	ACTIVE	SO	NS	16	2000	Green (RoHS & no Sb/Br)	CU NIPDAU	Level-1-260C-UNLIM
SN74LS166ANSRE4	ACTIVE	SO	NS	16	2000	Green (RoHS & no Sb/Br)	CU NIPDAU	Level-1-260C-UNLIM
SN74LS166ANSRE4	ACTIVE	SO	NS	16	2000	Green (RoHS & no Sb/Br)	CU NIPDAU	Level-1-260C-UNLIM
SNJ54166J	ACTIVE	CDIP	J	16	1	TBD	Call TI	Level-NC-NC-NC
SNJ54166J	ACTIVE	CDIP	J	16	1	TBD	Call TI	Level-NC-NC-NC
SNJ54166W	ACTIVE	CFP	W	16	1	TBD	Call TI	Level-NC-NC-NC
SNJ54166W	ACTIVE	CFP	W	16	1	TBD	Call TI	Level-NC-NC-NC
SNJ54LS166AFK	ACTIVE	LCCC	FK	20	1	TBD	Call TI	Level-NC-NC-NC
SNJ54LS166AFK	ACTIVE	LCCC	FK	20	1	TBD	Call TI	Level-NC-NC-NC
SNJ54LS166AJ	ACTIVE	CDIP	J	16	1	TBD	Call TI	Level-NC-NC-NC
SNJ54LS166AJ	ACTIVE	CDIP	J	16	1	TBD	Call TI	Level-NC-NC-NC
SNJ54LS166AW	ACTIVE	CFP	W	16	1	TBD	Call TI	Level-NC-NC-NC
SNJ54LS166AW	ACTIVE	CFP	W	16	1	TBD	Call TI	Level-NC-NC-NC

⁽¹⁾ The marketing status values are defined as follows:

ACTIVE: Product device recommended for new designs.

LIFEBUY: TI has announced that the device will be discontinued, and a lifetime-buy period is in effect.

NRND: Not recommended for new designs. Device is in production to support existing customers, but TI does not recommend using this part in a new design.

PREVIEW: Device has been announced but is not in production. Samples may or may not be available.

OBSOLETE: TI has discontinued the production of the device.

⁽²⁾ Eco Plan - The planned eco-friendly classification: Pb-Free (RoHS) or Green (RoHS & no Sb/Br) - please check <http://www.ti.com/productcontent> for the latest availability information and additional product content details.

TBD: The Pb-Free/Green conversion plan has not been defined.

Pb-Free (RoHS): TI's terms "Lead-Free" or "Pb-Free" mean semiconductor products that are compatible with the current RoHS requirements for all 6 substances, including the requirement that lead not exceed 0.1% by weight in homogeneous materials. Where designed to be soldered at high temperatures, TI Pb-Free products are suitable for use in specified lead-free processes.

Green (RoHS & no Sb/Br): TI defines "Green" to mean Pb-Free (RoHS compatible), and free of Bromine (Br) and Antimony (Sb) based flame retardants (Br or Sb do not exceed 0.1% by weight in homogeneous material)

⁽³⁾ MSL, Peak Temp. -- The Moisture Sensitivity Level rating according to the JEDEC industry standard classifications, and peak solder temperature.

Important Information and Disclaimer: The information provided on this page represents TI's knowledge and belief as of the date that it is provided. TI bases its knowledge and belief on information provided by third parties, and makes no representation or warranty as to the accuracy of such information. Efforts are underway to better integrate information from third parties. TI has taken and continues to take reasonable steps to provide representative and accurate information but may not have conducted destructive testing or chemical analysis on incoming materials and chemicals. TI and TI suppliers consider certain information to be proprietary, and thus CAS numbers and other limited information may not be available for release.

In no event shall TI's liability arising out of such information exceed the total purchase price of the TI part(s) at issue in this document sold by TI to Customer on an annual basis.

J (R-GDIP-T**)

14 LEADS SHOWN

CERAMIC DUAL IN-LINE PACKAGE

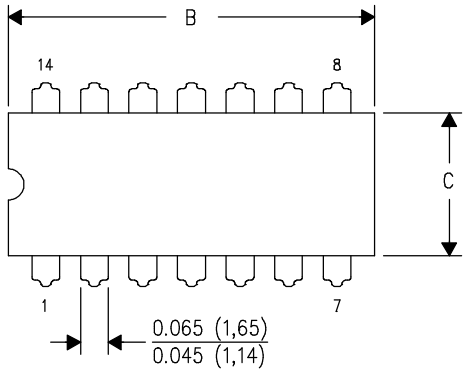

DIM \ PINS **	14	16	18	20
A	0.300 (7,62) BSC	0.300 (7,62) BSC	0.300 (7,62) BSC	0.300 (7,62) BSC
B MAX	0.785 (19,94)	.840 (21,34)	0.960 (24,38)	1.060 (26,92)
B MIN	—	—	—	—
C MAX	0.300 (7,62)	0.300 (7,62)	0.310 (7,87)	0.300 (7,62)
C MIN	0.245 (6,22)	0.245 (6,22)	0.220 (5,59)	0.245 (6,22)

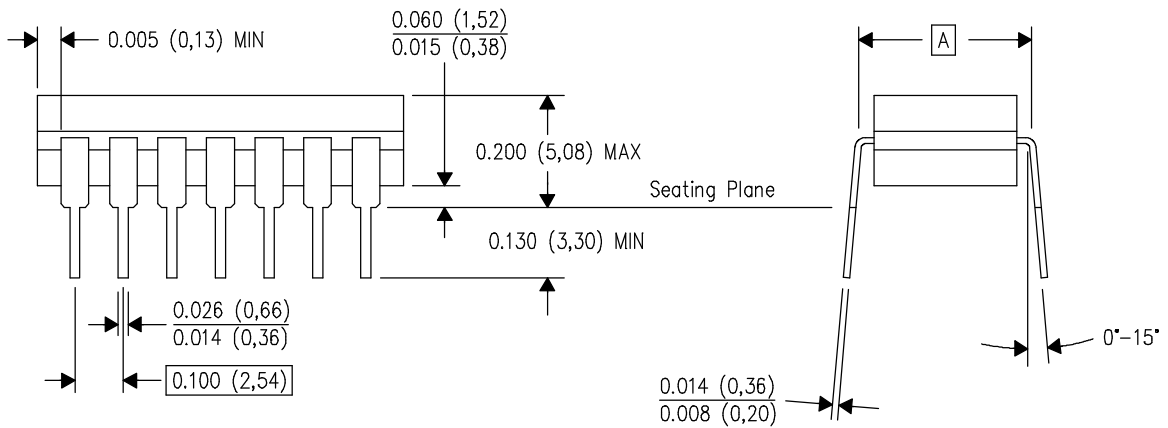

4040083/F 03/03

- NOTES:
- A. All linear dimensions are in inches (millimeters).
 - B. This drawing is subject to change without notice.
 - C. This package is hermetically sealed with a ceramic lid using glass frit.
 - D. Index point is provided on cap for terminal identification only on press ceramic glass frit seal only.
 - E. Falls within MIL STD 1835 GDIP1-T14, GDIP1-T16, GDIP1-T18 and GDIP1-T20.

MECHANICAL DATA

MLCC006B – OCTOBER 1996

FK (S-CQCC-N**)

LEADLESS CERAMIC CHIP CARRIER

28 TERMINAL SHOWN

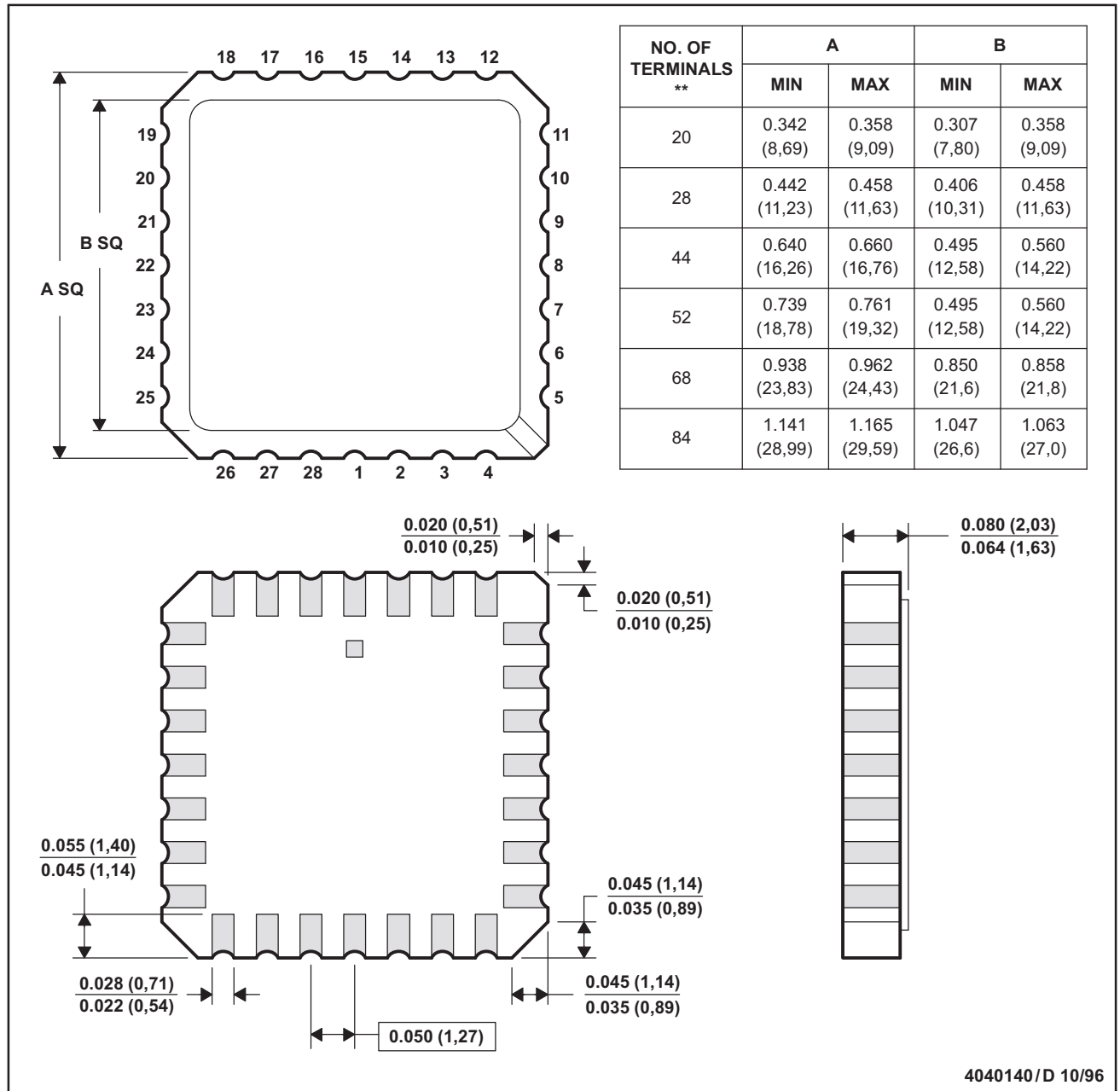

- NOTES: A. All linear dimensions are in inches (millimeters).
 B. This drawing is subject to change without notice.
 C. This package can be hermetically sealed with a metal lid.
 D. The terminals are gold plated.
 E. Falls within JEDEC MS-004



POST OFFICE BOX 655303 • DALLAS, TEXAS 75265

MECHANICAL DATA

N (R-PDIP-T**)

16 PINS SHOWN

PLASTIC DUAL-IN-LINE PACKAGE

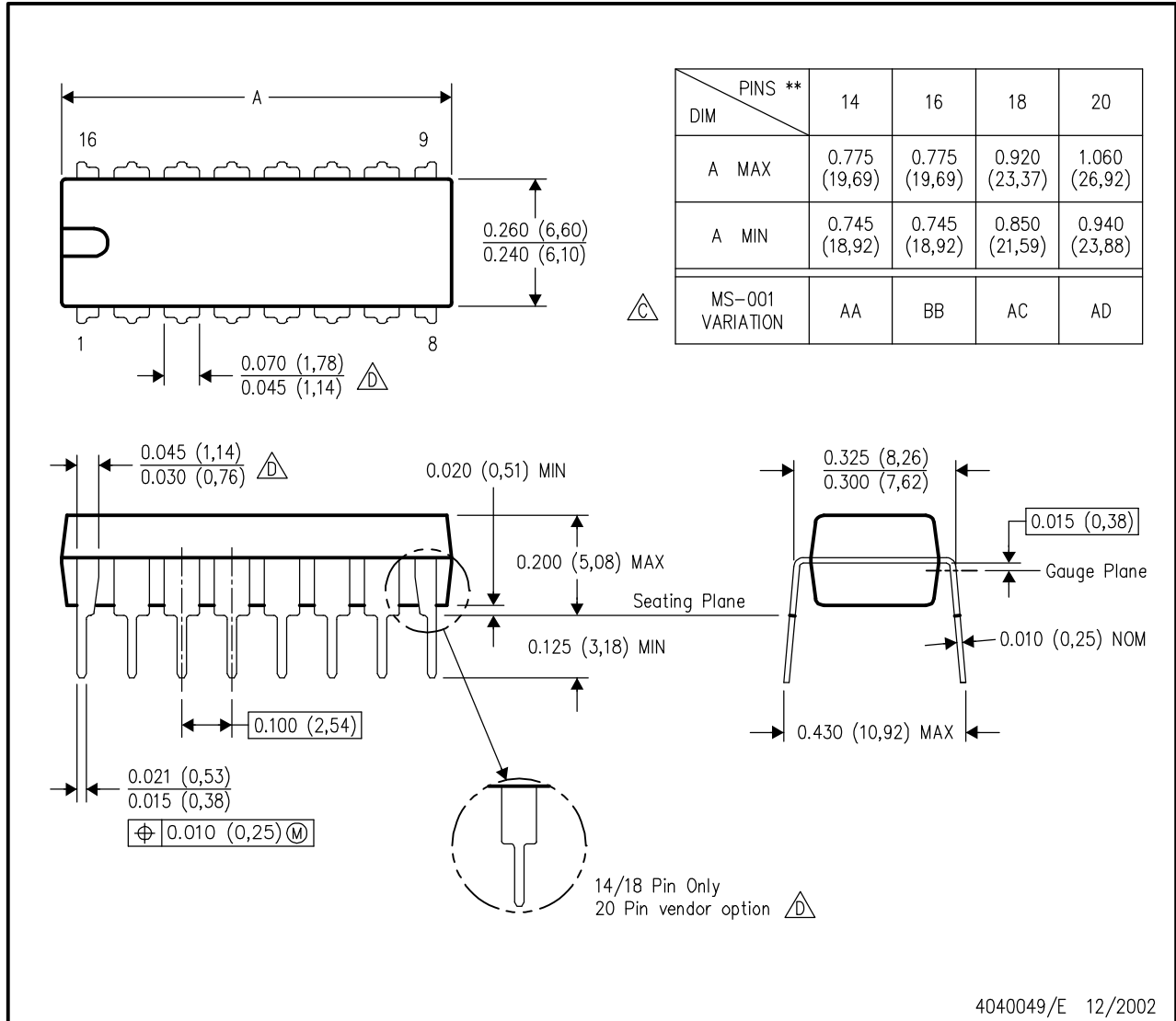

- NOTES:
- A. All linear dimensions are in inches (millimeters).
 - B. This drawing is subject to change without notice.
 - Falls within JEDEC MS-001, except 18 and 20 pin minimum body length (Dim A).
 - The 20 pin end lead shoulder width is a vendor option, either half or full width.

D (R-PDSO-G16)

PLASTIC SMALL-OUTLINE PACKAGE

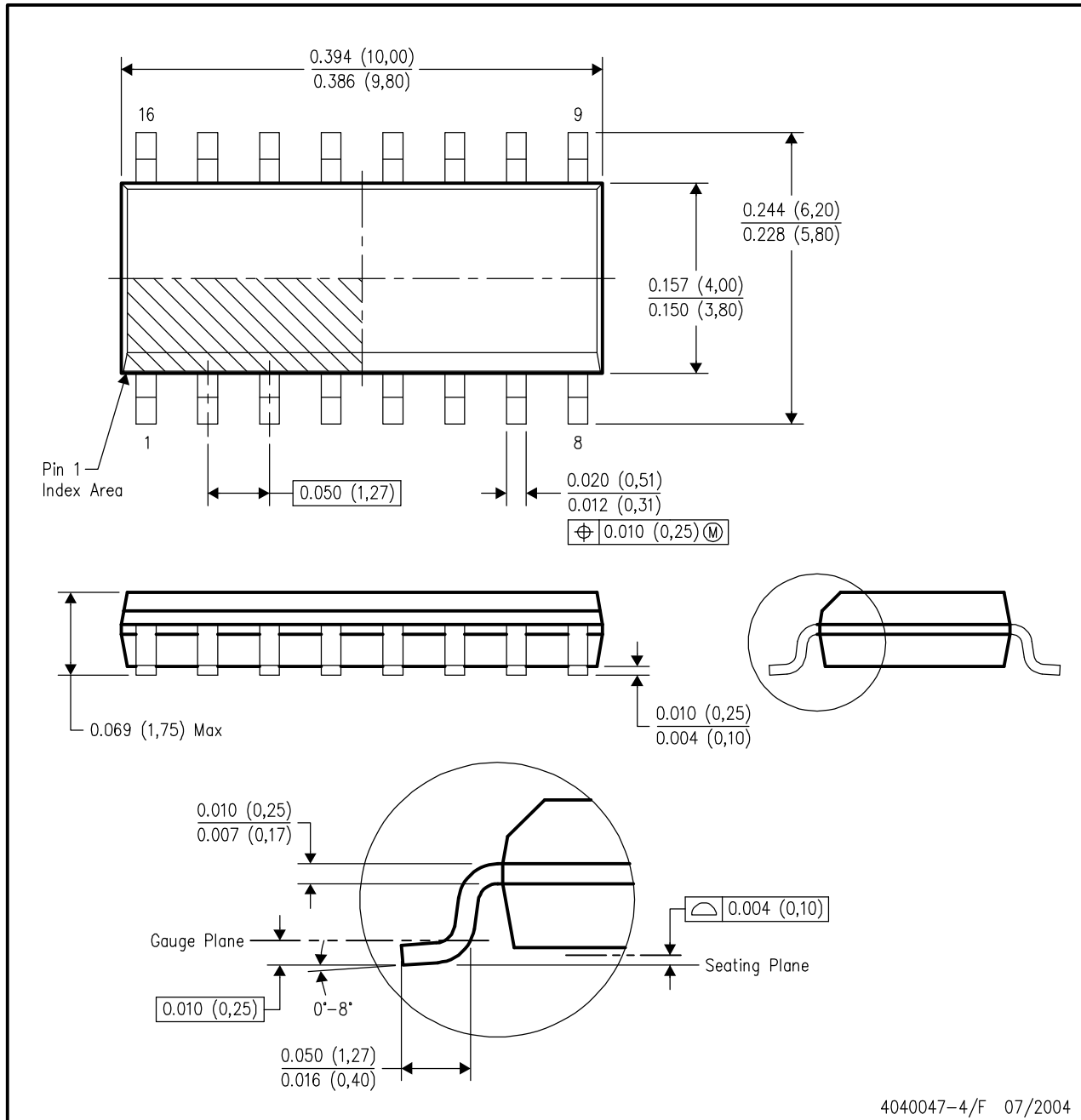

4040047-4/F 07/2004

- NOTES:
- A. All linear dimensions are in inches (millimeters).
 - B. This drawing is subject to change without notice.
 - C. Body dimensions do not include mold flash or protrusion not to exceed 0.006 (0,15).
 - D. Falls within JEDEC MS-012 variation AC.

MECHANICAL DATA

NS (R-PDSO-G)**

PLASTIC SMALL-OUTLINE PACKAGE

14-PINS SHOWN

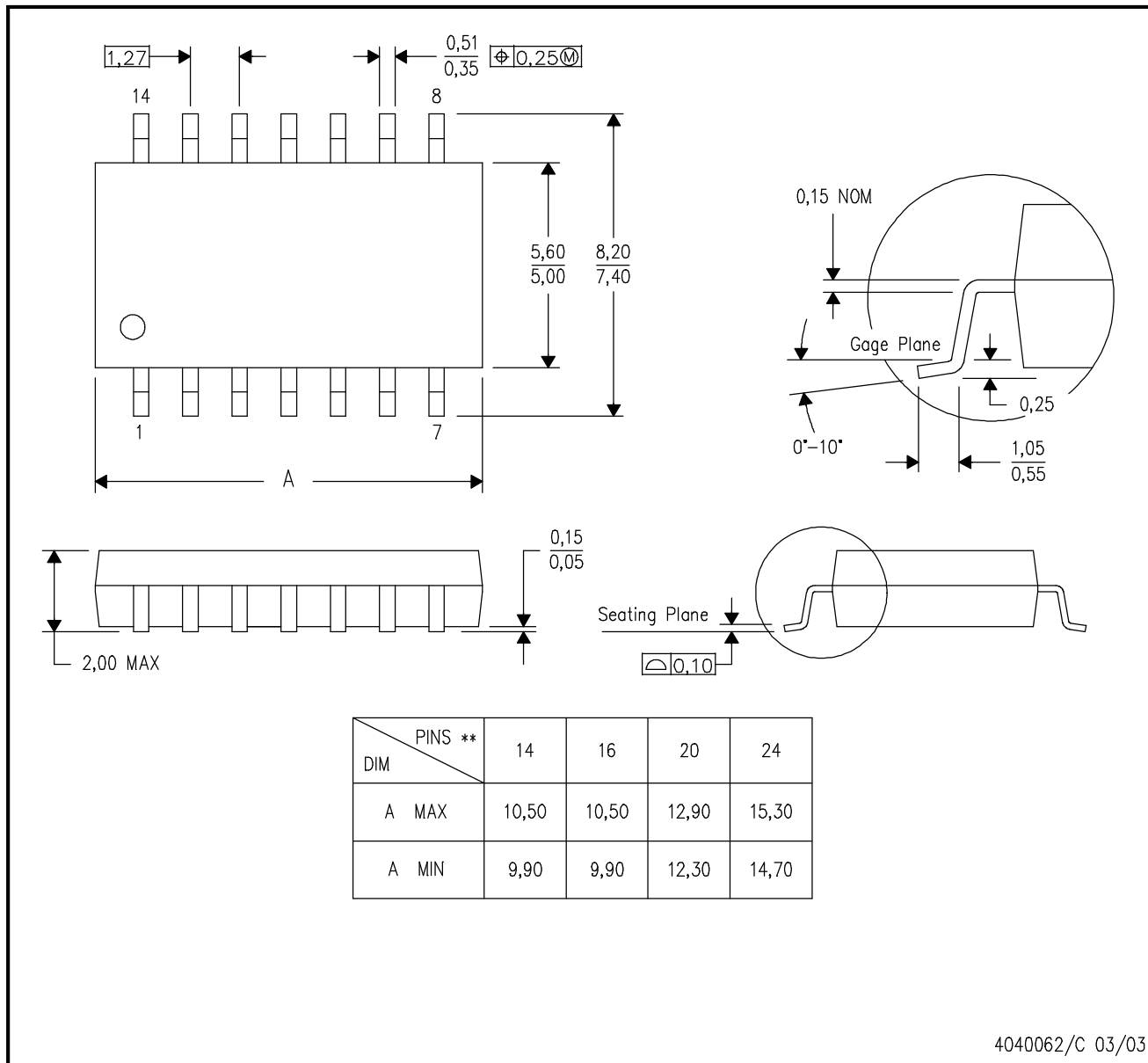

- NOTES:
- A. All linear dimensions are in millimeters.
 - B. This drawing is subject to change without notice.
 - C. Body dimensions do not include mold flash or protrusion, not to exceed 0,15.

IMPORTANT NOTICE

Texas Instruments Incorporated and its subsidiaries (TI) reserve the right to make corrections, modifications, enhancements, improvements, and other changes to its products and services at any time and to discontinue any product or service without notice. Customers should obtain the latest relevant information before placing orders and should verify that such information is current and complete. All products are sold subject to TI's terms and conditions of sale supplied at the time of order acknowledgment.

TI warrants performance of its hardware products to the specifications applicable at the time of sale in accordance with TI's standard warranty. Testing and other quality control techniques are used to the extent TI deems necessary to support this warranty. Except where mandated by government requirements, testing of all parameters of each product is not necessarily performed.

TI assumes no liability for applications assistance or customer product design. Customers are responsible for their products and applications using TI components. To minimize the risks associated with customer products and applications, customers should provide adequate design and operating safeguards.

TI does not warrant or represent that any license, either express or implied, is granted under any TI patent right, copyright, mask work right, or other TI intellectual property right relating to any combination, machine, or process in which TI products or services are used. Information published by TI regarding third-party products or services does not constitute a license from TI to use such products or services or a warranty or endorsement thereof. Use of such information may require a license from a third party under the patents or other intellectual property of the third party, or a license from TI under the patents or other intellectual property of TI.

Reproduction of information in TI data books or data sheets is permissible only if reproduction is without alteration and is accompanied by all associated warranties, conditions, limitations, and notices. Reproduction of this information with alteration is an unfair and deceptive business practice. TI is not responsible or liable for such altered documentation.

Resale of TI products or services with statements different from or beyond the parameters stated by TI for that product or service voids all express and any implied warranties for the associated TI product or service and is an unfair and deceptive business practice. TI is not responsible or liable for any such statements.

Following are URLs where you can obtain information on other Texas Instruments products and application solutions:

Products		Applications	
Amplifiers	amplifier.ti.com	Audio	www.ti.com/audio
Data Converters	dataconverter.ti.com	Automotive	www.ti.com/automotive
DSP	dsp.ti.com	Broadband	www.ti.com/broadband
Interface	interface.ti.com	Digital Control	www.ti.com/digitalcontrol
Logic	logic.ti.com	Military	www.ti.com/military
Power Mgmt	power.ti.com	Optical Networking	www.ti.com/opticalnetwork
Microcontrollers	microcontroller.ti.com	Security	www.ti.com/security
		Telephony	www.ti.com/telephony
		Video & Imaging	www.ti.com/video
		Wireless	www.ti.com/wireless

Mailing Address: Texas Instruments
Post Office Box 655303 Dallas, Texas 75265

Copyright © 2005, Texas Instruments Incorporated