

SN54155, SN54156, SN54LS155A, SN54LS156, SN74155, SN74156, SN74LS155A, SN74LS156 DUAL 2-LINE TO 4-LINE DECODERS/DEMULTIPLEXERS

SDLS057 - MARCH 1974 - REVISED MARCH 1988

- **Applications:**
 - Dual 2-to 4-Line Decoder
 - Dual 1-to 4-Line Demultiplexer
 - 3-to 8-Line Decoder
 - 1-to 8-Line Demultiplexer
- **Individual Strobes Simplify Cascading for Decoding or Demultiplexing Larger Words**
- **Input Clamping Diodes Simplify System Design**
- **Choice of Outputs:**
 - Totem Pole ('155, 'LS155A)
 - Open-Collector ('156, 'LS156)

SN54155, SN54156, SN54LS155A,
SN54LS156 . . . J OR W PACKAGE
SN74155, SN74156 . . . N PACKAGE
SN74LS155A, SN74LS156 . . . D OR N PACKAGE
(TOP VIEW)

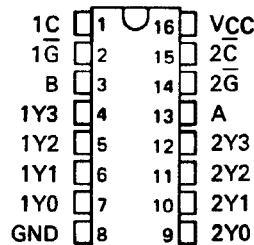

TYPES	TYPICAL AVERAGE PROPAGATION DELAY 3 GATE LEVELS	TYPICAL POWER DISSIPATION
'155, '156	21 ns	125 mW
'LS155A	18 ns	31 mW
'LS156	32 ns	31 mW

description

These monolithic transistor-transistor-logic (TTL) circuits feature dual 1-line-to-4-line demultiplexers with individual strobes and common binary-address inputs in a single 16-pin package. When both sections are enabled by the strobes, the common binary-address inputs sequentially select and route associated input data to the appropriate output of each section. The individual strobes permit activating or inhibiting each of the 4-bit sections as desired. Data applied to input 1C is inverted at its outputs and data applied at 2C is not inverted through its outputs. The inverter following the 1C data input permits use as a 3-to-8-line decoder or 1-to-8-line demultiplexer without external gating. Input clamping diodes are provided on all of these circuits to minimize transmission-line effects and simplify system design.

SN54LS155A, SN54LS156 . . . FK PACKAGE
(TOP VIEW)

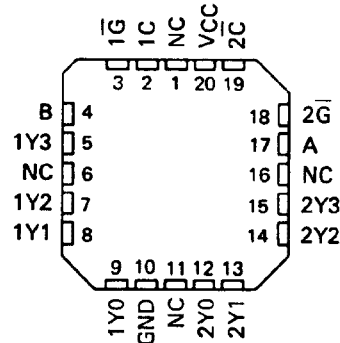

NC - No internal connection

logic symbols (2-line to 4-line decoder)†

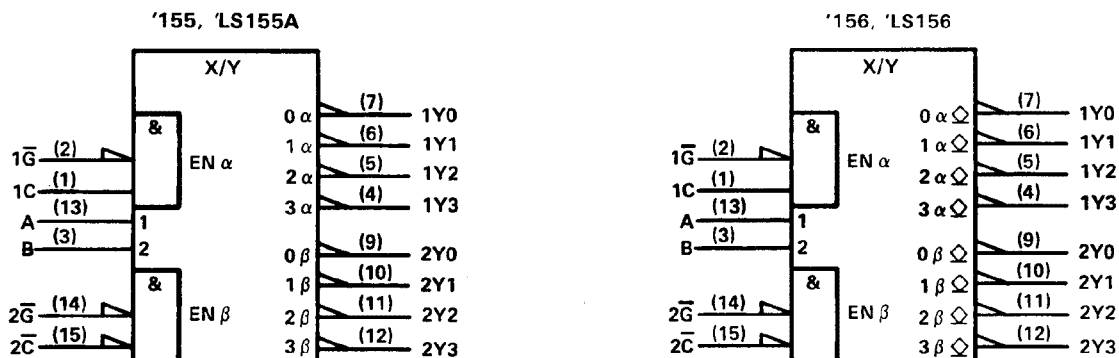

† These symbols are in accordance with ANSI/IEEE Std. 91-1984 and IEC Publication 617-12. For alternative symbols for other applications, see the following page.

Pin numbers shown are for D, J, N, and W packages.

PRODUCTION DATA information is current as of publication date. Products conform to specifications per the terms of Texas Instruments standard warranty. Production processing does not necessarily include testing of all parameters.

 **TEXAS
INSTRUMENTS**

POST OFFICE BOX 655303 • DALLAS, TEXAS 75265

Copyright © 1988, Texas Instruments Incorporated

SN54155, SN54156, SN54LS155A, SN54LS156, SN74155, SN74156, SN74LS155A, SN74LS156

DUAL 2-LINE TO 4-LINE DECODERS/DEMULTIPLEXERS

SDLS057 – MARCH 1974 – REVISED MARCH 1988

additional logic symbols (alternatives)†

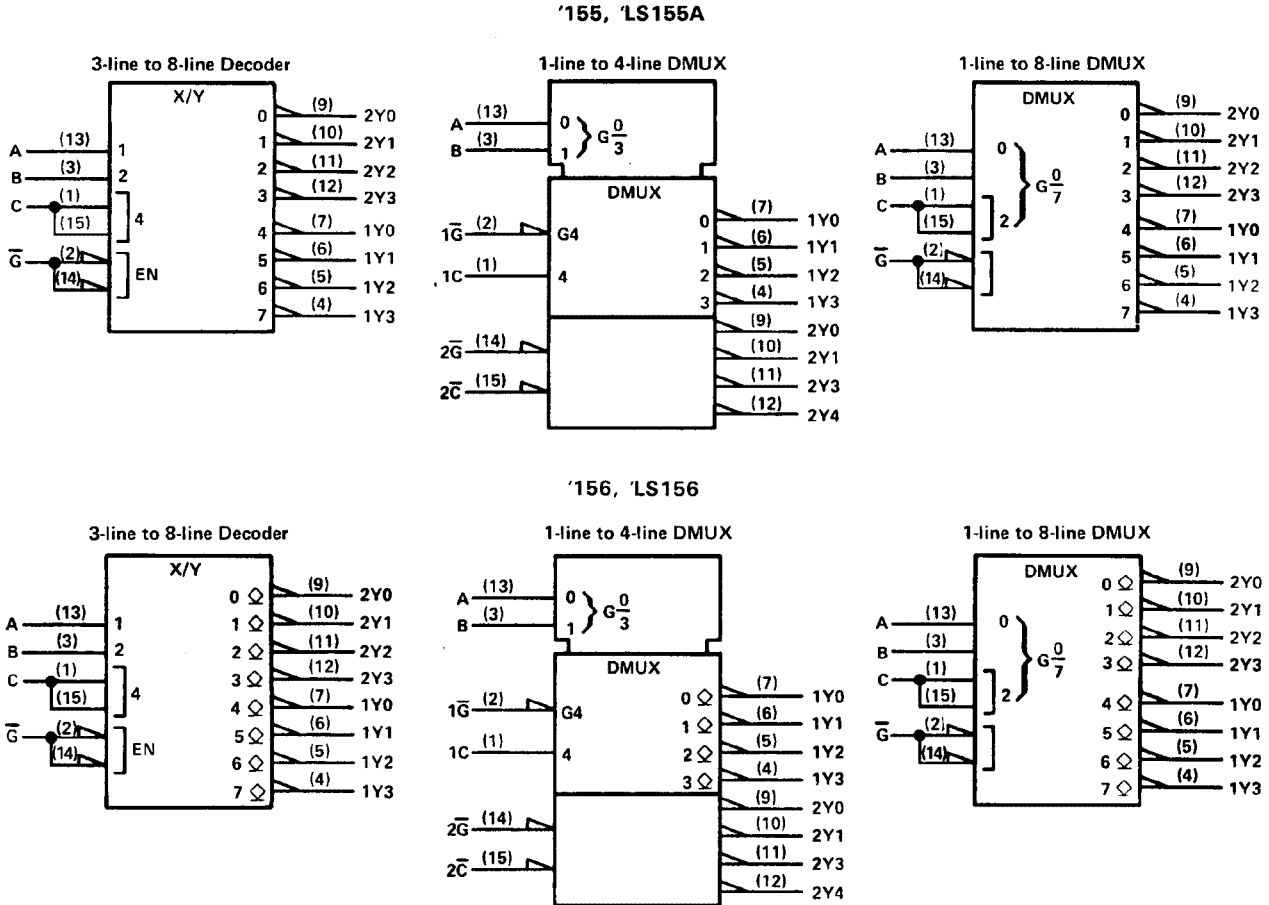

†These symbols are in accordance with ANSI/IEEE Std 91-1984 and IEC Publication 617-12. Pin numbers shown are for D, J, N, and W packages.

schematics of inputs and outputs

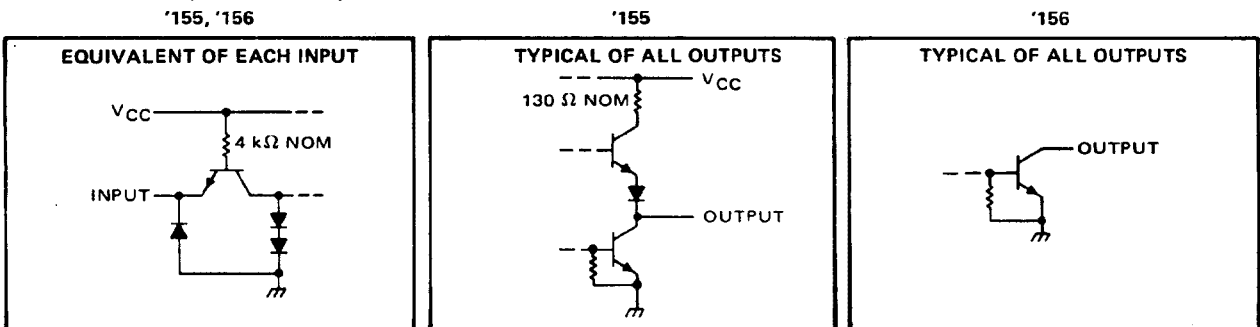

SN54155, SN54156, SN54LS155A, SN54LS156, SN74155, SN74156, SN74LS155A, SN74LS156 DUAL 2-LINE TO 4-LINE DECODERS/DEMULTIPLEXERS

SDLS057 - MARCH 1974 - REVISED MARCH 1988

schematics of inputs and outputs (continued)

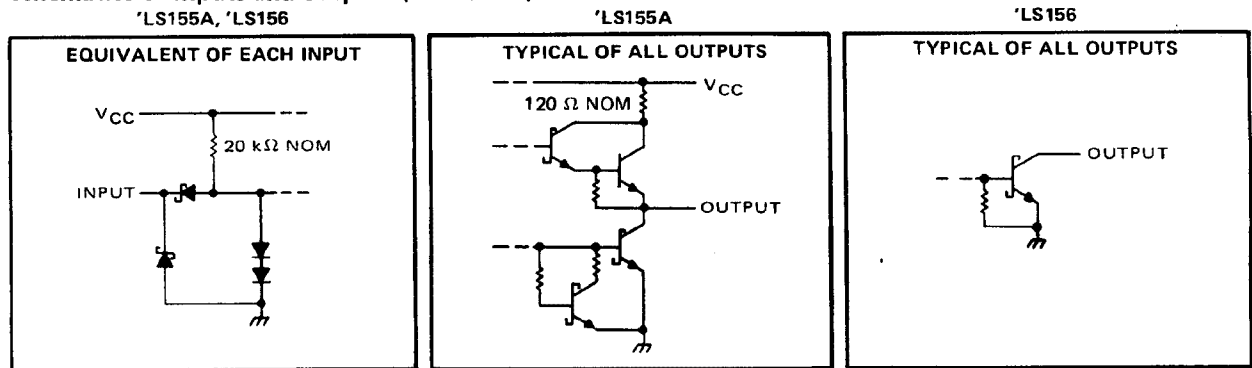

logic diagram (positive logic)

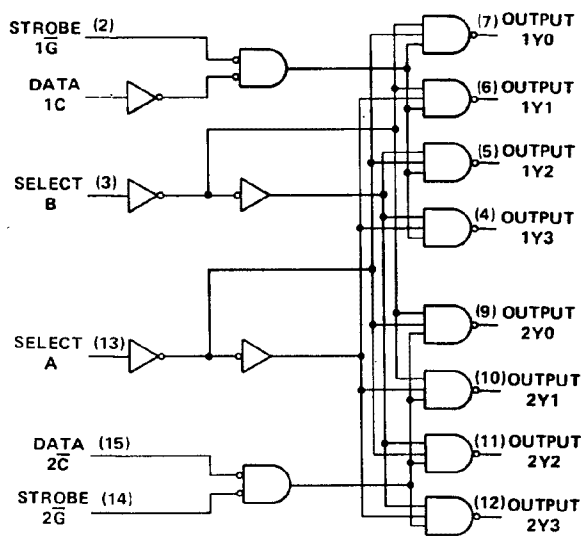

FUNCTION TABLES

2-LINE-TO-4-LINE DECODER

OR 1-LINE-TO-4-LINE DEMULTIPLEXER

INPUTS				OUTPUTS			
SELECT		STROBE	DATA	1Y0	1Y1	1Y2	1Y3
B	A	1G	1C				
X	X	H	X	H	H	H	H
L	L	L	H	L	H	H	H
L	H	L	H	H	L	H	H
H	L	L	H	H	H	L	H
H	H	L	H	H	H	H	L
X	X	X	L	H	H	H	H

INPUTS				OUTPUTS			
SELECT		STROBE	DATA	2Y0	2Y1	2Y2	2Y3
B	A	2G	2C				
X	X	H	X	H	H	H	H
L	L	L	L	L	H	H	H
L	H	L	L	H	L	H	H
H	L	L	L	H	H	L	H
H	H	L	L	H	H	H	L
X	X	X	H	H	H	H	H

FUNCTION TABLE

3-LINE-TO-8-LINE DECODER

OR 1-LINE-TO-8-LINE DEMULTIPLEXER

INPUTS				OUTPUTS							
SELECT			STROBE OR DATA	(0)	(1)	(2)	(3)	(4)	(5)	(6)	(7)
C†	B	A	G‡	2Y0	2Y1	2Y2	2Y3	1Y0	1Y1	1Y2	1Y3
X	X	X	H	H	H	H	H	H	H	H	H
L	L	L	L	L	H	H	H	H	H	H	H
L	L	H	L	H	L	H	H	H	H	H	H
L	H	L	L	H	H	L	H	H	H	H	H
L	H	H	L	H	H	H	L	H	H	H	H
H	L	L	L	H	H	H	H	L	H	H	H
H	L	H	L	H	H	H	H	H	L	H	H
H	H	L	L	H	H	H	H	H	H	L	H
H	H	H	L	H	H	H	H	H	H	H	L

† C = inputs 1C and 2C connected together

‡ G = inputs 1G and 2G connected together

H = high level, L = low level, X = irrelevant



POST OFFICE BOX 655303 • DALLAS, TEXAS 75265

SN54155, SN54156, SN54LS155A, SN54LS156, SN74155, SN74156, SN74LS155A, SN74LS156 DUAL 2-LINE TO 4-LINE DECODERS/DEMULTIPLEXERS

SDLS057 – MARCH 1974 – REVISED MARCH 1988

absolute maximum ratings over operating free-air temperature range (unless otherwise noted)

Supply voltage, V_{CC} (see Note 1)	7 V
Input voltage: '155, '156	5.5 V
'LS155A, 'LS156	7 V
Off-state output voltage: '156	5.5 V
'LS156	7 V
Operating free-air temperature range: SN54', SN54LS' Circuits	-55°C to 125°C
SN74', SN74LS' Circuits	0°C to 70°C
Storage temperature range	-65°C to 150°C

NOTE 1: Voltage values are with respect to network ground terminal.

recommended operating conditions

	SN54155			SN74155			UNIT
	MIN	NOM	MAX	MIN	NOM	MAX	
Supply voltage, V_{CC}	4.5	5	5.5	4.75	5	5.25	V
High-level output current, I_{OH}			-800			-800	μ A
Low-level output current, I_{OL}			16			16	mA
Operating free-air temperature, T_A	-55		125	0		70	°C

electrical characteristics over recommended operating free-air temperature range (unless otherwise noted)

PARAMETER	TEST CONDITIONS†	SN54155 SN74155			UNIT
		MIN	TYP‡	MAX	
V_{IH} High-level input voltage		2			V
V_{IL} Low-level input voltage				0.8	V
V_{IK} Input clamp voltage	$V_{CC} = \text{MIN}, I_I = -8 \text{ mA}$			-1.5	V
V_{OH} High-level output voltage	$V_{CC} = \text{MIN}, V_{IH} = 2 \text{ V}, V_{IL} = 0.8 \text{ V}, I_{OH} = -800 \mu\text{A}$	2.4	3.4		V
V_{OL} Low-level output voltage	$V_{CC} = \text{MIN}, V_{IH} = 2 \text{ V}, V_{IL} = 0.8 \text{ V}, I_{OL} = 16 \text{ mA}$	0.2	0.4		V
I_I Input current at maximum input voltage	$V_{CC} = \text{MAX}, V_I = 5.5 \text{ V}$			1	mA
I_{IH} High-level input current	$V_{CC} = \text{MAX}, V_I = 2.4 \text{ V}$			40	μ A
I_{IL} Low-level input current	$V_{CC} = \text{MAX}, V_I = 0.4 \text{ V}$			-1.6	mA
I_{OS} Short-circuit output current§	$V_{CC} = \text{MAX}$	SN54155	-20	-55	mA
		SN74155	-18	-57	
I_{CC} Supply current	$V_{CC} = \text{MAX},$ See Note 2	SN54155	25	35	mA
		SN74155	25	40	

†For conditions shown as MIN or MAX, use the appropriate value specified under recommended operating conditions.

‡All typical values are at $V_{CC} = 5 \text{ V}, T_A = 25^\circ\text{C}$.

§Not more than one output should be shorted at a time.

NOTE 2: I_{CC} is measured with outputs open, A, B, and 1C inputs at 4.5 V, and 2C, 1G, and 2G inputs grounded.

switching characteristics, $V_{CC} = 5 \text{ V}, T_A = 25^\circ\text{C}$

PARAMETER	FROM (INPUT)	TO (OUTPUT)	LEVELS OF LOGIC	TEST CONDITIONS	SN54155 SN74155			UNIT
					MIN	TYP	MAX	
t_{PLH}	A, B, 2C, 1G, or 2G	Y	2	$C_L = 15 \text{ pF}, R_L = 400 \Omega,$ See Note 3	13	20	ns	
t_{PHL}	A, B, 2C, 1G, or 2G	Y	2		18	27	ns	
t_{PLH}	A or B	y	3		21	32	ns	
t_{PHL}	A or B	Y	3		21	32	ns	
t_{PLH}	1C	Y	3		16	24	ns	
t_{PHL}	1C	Y	3		20	30	ns	

NOTE 3: Load circuits and voltage waveforms are shown in Section 1.



SN54155A, SN74155A

DUAL 2-LINE TO 4-LINE DECODERS/DEMULTIPLEXERS

SDLS057 – MARCH 1974 – REVISED MARCH 1988

recommended operating conditions

	SN54156			SN74156			UNIT
	MIN	NOM	MAX	MIN	NOM	MAX	
Supply voltage, V_{CC}	4.5	5	5.5	4.75	5	5.25	V
High-level output voltage, V_{OH}				5.5			V
Low-level output current, I_{OL}	16			16			mA
Operating free-air temperature, T_A	-55			125			°C

electrical characteristics over recommended operating free-air temperature range (unless otherwise noted)

PARAMETER	TEST CONDITIONS†	SN54156		UNIT	
		SN74156			
		MIN	TYP‡	MAX	
V_{IH} High-level input voltage		2		V	
V_{IL} Low-level input voltage		0.8		V	
V_{IK} Input clamp voltage		-1.5		V	
I_{OH} High-level output current	$V_{CC} = \text{MIN}, V_{IH} = 2 \text{ V}, V_{IL} = 0.8 \text{ V}, V_{OH} = 5.5 \text{ V}$	250		µA	
V_{OL} Low-level output voltage	$V_{CC} = \text{MIN}, V_{IH} = 2 \text{ V}, V_{IL} = 0.8 \text{ V}, I_{OL} = 16 \text{ mA}$	0.2	0.4	V	
I_I Input current at maximum input voltage	$V_{CC} = \text{MAX}, V_I = 5.5 \text{ V}$	1		mA	
I_{IH} High-level input current	$V_{CC} = \text{MAX}, V_I = 2.4 \text{ V}$	40		µA	
I_{IL} Low-level input current	$V_{CC} = \text{MAX}, V_I = 0.4 \text{ V}$	-1.6		mA	
I_{CC} Supply current	$V_{CC} = \text{MAX},$ See Note 2	SN54156	25	35	mA
		SN74156	25	40	

† For conditions shown as MIN or MAX, use the appropriate value specified under recommended operating conditions.

‡ All typical values are at $V_{CC} = 5 \text{ V}, T_A = 25^\circ\text{C}$.

NOTE 2: I_{CC} is measured with outputs open, A, B, and 1C inputs at 4.5 V, and 2C, 1G, and 2G inputs grounded.

switching characteristics, $V_{CC} = 5 \text{ V}, T_A = 25^\circ\text{C}$

PARAMETER§	FROM (INPUT)	TO (OUTPUT)	LEVELS OF LOGIC	TEST CONDITIONS	SN54156			UNIT
					SN74156	MIN	TYP	
t_{PLH}	A, B, 2C, 1G, or 2G	Y	2	$C_L = 15 \text{ pF},$ $R_L = 400 \Omega,$ See Note 3	15	23	ns	
t_{PHL}	A, B, 2C, 1G, or 2G	Y	2		20	30	ns	
t_{PLH}	A or B	y	3		23	34	ns	
t_{PHL}	A or B	Y	3		23	34	ns	
t_{PLH}	1C	Y	3		18	27	ns	
t_{PHL}	1C	Y	3		22	33	ns	

§ t_{PLH} = propagation delay time, low-to-high-level output

t_{PHL} = propagation delay time, high-to-low-level output

NOTE 3: Load circuits and voltage waveforms are shown in Section 1.



SN54LS155A, SN74LS155A DUAL 2-LINE TO 4-LINE DECODERS/DEMULTIPLEXERS

SDLS057 – MARCH 1974 – REVISED MARCH 1988

recommended operating conditions

	SN54LS155A			SN74LS155A			UNIT
	MIN	NOM	MAX	MIN	NOM	MAX	
Supply voltage, V_{CC}	4.5	5	5.5	4.75	5	5.25	V
High-level output current, I_{OH}			-400			-400	μ A
Low-level output current, I_{OL}			4			8	mA
Operating free-air temperature, T_A	-55		125	0		70	$^{\circ}$ C

electrical characteristics over recommended operating free-air temperature range (unless otherwise noted)

PARAMETER	TEST CONDITIONS†	SN54LS155A		SN74LS155A		UNIT		
		MIN	TYP‡	MAX	MIN		TYP‡	MAX
V_{IH} High-level input voltage		2			2	V		
V_{IL} Low-level input voltage				0.7		0.8	V	
V_{IK} Input clamp voltage	$V_{CC} = \text{MIN}, I_I = -18 \text{ mA}$			-1.5		-1.5	V	
V_{OH} High-level output voltage	$V_{CC} = \text{MIN}, V_{IH} = 2 \text{ V}, V_{IL} = V_{IL \text{ max}}, I_{OH} = -400 \mu\text{A}$	2.5	3.4		2.7	3.4	V	
V_{OL} Low-level output voltage	$V_{CC} = \text{MIN}, V_{IH} = 2 \text{ V}, V_{IL} = V_{IL \text{ max}}$			0.25	0.4	0.25	0.4	V
				$I_{OL} = 4 \text{ mA}$		0.35	0.5	
				$I_{OL} = 8 \text{ mA}$				
I_I Input current at maximum input voltage	$V_{CC} = \text{MAX}, V_I = 7 \text{ V}$			0.1		0.1	mA	
I_{IH} High-level input current	$V_{CC} = \text{MAX}, V_I = 2.7 \text{ V}$			20		20	μ A	
I_{IL} Low-level input current	$V_{CC} = \text{MAX}, V_I = 0.4 \text{ V}$			-0.4		-0.4	mA	
I_{OS} Short-circuit output current§	$V_{CC} = \text{MAX}$	-20		-100		-20	-100	mA
I_{CC} Supply current	$V_{CC} = \text{MAX}, \text{ See Note 2}$		6.1	10		6.1	10	mA

† For conditions shown as MIN or MAX, use the appropriate value specified under recommended operating conditions.

‡ All typical values are at $V_{CC} = 5 \text{ V}, T_A = 25^{\circ}\text{C}$.

§ Not more than one output should be shorted at a time.

NOTE 2: I_{CC} is measured with outputs open, A, B, and 1C inputs at 4.5 V, and 2C, 1G, and 2G inputs grounded.

switching characteristics, $V_{CC} = 5 \text{ V}, T_A = 25^{\circ}\text{C}$

PARAMETER¶	FROM (INPUT)	TO (OUTPUT)	LEVELS OF LOGIC	TEST CONDITIONS	SN54LS155A SN74LS155A		UNIT
					MIN	TYP	
t_{PLH}	A, B, 2C, 1G, or 2G	Y	2	$C_L = 15 \text{ pF}, R_L = 2 \text{ k}\Omega, \text{ See Note 3}$	10	15	ns
t_{PHL}	A, B, 2C, 1G, or 2G	Y	2		19	30	ns
t_{PLH}	A or B	Y	3		17	26	ns
t_{PHL}	A or B	Y	3		19	30	ns
t_{PLH}	1C	Y	3		18	27	ns
t_{PHL}	1C	Y	3		18	27	ns

¶ t_{PLH} = propagation delay time, low-to-high-level output

t_{PHL} = propagation delay time, high-to-low-level output

NOTE 3: Load circuits and voltage waveforms are shown in Section 1.



POST OFFICE BOX 655303 • DALLAS, TEXAS 75265

SN54LS156A, SN74LS156A DUAL 2-LINE TO 4-LINE DECODERS/DEMULTIPLEXERS

SDLS057 – MARCH 1974 – REVISED MARCH 1988

recommended operating conditions

	SN54LS156			SN74LS156			UNIT		
	MIN	NOM	MAX	MIN	NOM	MAX			
Supply voltage, V_{CC}	4.5	5	5.5	4.75	5	5.25	V		
High-level output voltage, V_{OH}	5.5			5.5			V		
Low-level output current, I_{OL}	4			8			mA		
Operating free-air temperature, T_A	-55			125			0	70	°C

electrical characteristics over recommended operating free-air temperature range (unless otherwise noted)

PARAMETER	TEST CONDITIONS†	SN54LS156		SN74LS156		UNIT	
		MIN	TYP‡	MAX	MIN		TYP‡
V_{IH} High-level input voltage		2		2		V	
V_{IL} Low-level input voltage		0.7		0.8		V	
V_{IK} Input clamp voltage	$V_{CC} = \text{MIN}, I_I = -18 \text{ mA}$	-1.5		-1.5		V	
I_{OH} High-level output current	$V_{CC} = \text{MIN}, V_{IH} = 2 \text{ V}, V_{IL} = V_{IL \text{ max}}, V_{OH} = 5.5 \text{ V}$	100		100		μA	
V_{OL} Low-level output voltage	$V_{CC} = \text{MIN}, V_{IH} = 2 \text{ V}, V_{IL} = V_{IL \text{ max}}$	$I_{OL} = 4 \text{ mA}$	0.25	0.4	0.25	0.4	V
		$I_{OL} = 8 \text{ mA}$			0.35	0.5	
I_I Input current at maximum input voltage	$V_{CC} = \text{MAX}, V_I = 7 \text{ V}$	0.1		0.1		mA	
I_{IH} High-level input current	$V_{CC} = \text{MAX}, V_I = 2.7 \text{ V}$	20		20		μA	
I_{IL} Low-level input current	$V_{CC} = \text{MAX}, V_I = 0.4 \text{ V}$	-0.4		-0.4		mA	
I_{CC} Supply current	$V_{CC} = \text{MAX},$ See Note 2	6.1	10	6.1	10	mA	

† For conditions shown as MIN or MAX, use the appropriate value specified under recommended operating conditions.

‡ All typical values are at $V_{CC} = 5 \text{ V}, T_A = 25^\circ \text{C}$.

NOTE 2: I_{CC} is measured with outputs open, A, B, and 1C inputs at 4.5 V, and 2C, 1G, and 2G inputs grounded.

switching characteristics, $V_{CC} = 5 \text{ V}, T_A = 25^\circ \text{C}$

PARAMETER§	FROM (INPUT)	TO (OUTPUT)	LEVELS OF LOGIC	TEST CONDITIONS	SN54LS156 SN74LS156			UNIT
					MIN	TYP	MAX	
t_{PLH}	A, B, $2\bar{C}$ $1\bar{G}$, or $2\bar{G}$	Y	2	$C_L = 15 \text{ pF},$ $R_L = 2 \text{ k}\Omega,$ See Note 3	25	40	ns	
t_{PHL}	A, B, $2\bar{C}$, $1\bar{G}$, or $2\bar{G}$	Y	2		34	51	ns	
t_{PLH}	A or B	Y	3		31	46	ns	
t_{PHL}	A or B	Y	3		34	51	ns	
t_{PLH}	1C	Y	3		32	48	ns	
t_{PHL}	1C	Y	3		32	48	ns	

§ t_{PLH} = propagation delay time, low-to-high-level output

t_{PHL} = propagation delay time, high-to-low-level output

NOTE 3: Load circuits and voltage waveforms are shown in Section 1.



PACKAGING INFORMATION

Orderable Device	Status ⁽¹⁾	Package Type	Package Drawing	Pins	Package Qty	Eco Plan ⁽²⁾	Lead/Ball Finish	MSL Peak Temp ⁽³⁾
5962-9750801Q2A	ACTIVE	LCCC	FK	20	1	TBD	Call TI	Level-NC-NC-NC
5962-9750801QEA	ACTIVE	CDIP	J	16	1	TBD	Call TI	Level-NC-NC-NC
5962-9750801QEA	ACTIVE	CDIP	J	16	1	TBD	Call TI	Level-NC-NC-NC
5962-9750801QFA	ACTIVE	CFP	W	16	1	TBD	Call TI	Level-NC-NC-NC
5962-9750801QFA	ACTIVE	CFP	W	16	1	TBD	Call TI	Level-NC-NC-NC
SN54155J	OBSOLETE	CDIP	J	16		TBD	Call TI	Call TI
SN54155J	OBSOLETE	CDIP	J	16		TBD	Call TI	Call TI
SN54LS155AJ	ACTIVE	CDIP	J	16	1	TBD	Call TI	Level-NC-NC-NC
SN54LS155AJ	ACTIVE	CDIP	J	16	1	TBD	Call TI	Level-NC-NC-NC
SN54LS156J	ACTIVE	CDIP	J	16	1	TBD	Call TI	Level-NC-NC-NC
SN54LS156J	ACTIVE	CDIP	J	16	1	TBD	Call TI	Level-NC-NC-NC
SN74155N	OBSOLETE	PDIP	N	16		TBD	Call TI	Call TI
SN74155N	OBSOLETE	PDIP	N	16		TBD	Call TI	Call TI
SN74155N3	OBSOLETE	PDIP	N	16		TBD	Call TI	Call TI
SN74155N3	OBSOLETE	PDIP	N	16		TBD	Call TI	Call TI
SN74156N	OBSOLETE	PDIP	N	16		TBD	Call TI	Call TI
SN74156N	OBSOLETE	PDIP	N	16		TBD	Call TI	Call TI
SN74LS155AD	ACTIVE	SOIC	D	16	40	Green (RoHS & no Sb/Br)	CU NIPDAU	Level-1-260C-UNLIM
SN74LS155AD	ACTIVE	SOIC	D	16	40	Green (RoHS & no Sb/Br)	CU NIPDAU	Level-1-260C-UNLIM
SN74LS155ADE4	ACTIVE	SOIC	D	16	40	Green (RoHS & no Sb/Br)	CU NIPDAU	Level-1-260C-UNLIM
SN74LS155ADE4	ACTIVE	SOIC	D	16	40	Green (RoHS & no Sb/Br)	CU NIPDAU	Level-1-260C-UNLIM
SN74LS155ADR	ACTIVE	SOIC	D	16	2500	Green (RoHS & no Sb/Br)	CU NIPDAU	Level-1-260C-UNLIM
SN74LS155ADR	ACTIVE	SOIC	D	16	2500	Green (RoHS & no Sb/Br)	CU NIPDAU	Level-1-260C-UNLIM
SN74LS155ADRE4	ACTIVE	SOIC	D	16	2500	Green (RoHS & no Sb/Br)	CU NIPDAU	Level-1-260C-UNLIM
SN74LS155ADRE4	ACTIVE	SOIC	D	16	2500	Green (RoHS & no Sb/Br)	CU NIPDAU	Level-1-260C-UNLIM
SN74LS155AN	ACTIVE	PDIP	N	16	25	Pb-Free (RoHS)	CU NIPDAU	Level-NC-NC-NC
SN74LS155AN	ACTIVE	PDIP	N	16	25	Pb-Free (RoHS)	CU NIPDAU	Level-NC-NC-NC
SN74LS155ANE4	ACTIVE	PDIP	N	16	25	Pb-Free (RoHS)	CU NIPDAU	Level-NC-NC-NC
SN74LS155ANE4	ACTIVE	PDIP	N	16	25	Pb-Free (RoHS)	CU NIPDAU	Level-NC-NC-NC
SN74LS155ANSR	ACTIVE	SO	NS	16	2000	Green (RoHS & no Sb/Br)	CU NIPDAU	Level-1-260C-UNLIM
SN74LS155ANSR	ACTIVE	SO	NS	16	2000	Green (RoHS & no Sb/Br)	CU NIPDAU	Level-1-260C-UNLIM
SN74LS155ANSRE4	ACTIVE	SO	NS	16	2000	Green (RoHS & no Sb/Br)	CU NIPDAU	Level-1-260C-UNLIM

Orderable Device	Status ⁽¹⁾	Package Type	Package Drawing	Pins	Package Qty	Eco Plan ⁽²⁾	Lead/Ball Finish	MSL Peak Temp ⁽³⁾
						no Sb/Br)		
SN74LS155ANSRE4	ACTIVE	SO	NS	16	2000	Green (RoHS & no Sb/Br)	CU NIPDAU	Level-1-260C-UNLIM
SN74LS156D	ACTIVE	SOIC	D	16	40	Green (RoHS & no Sb/Br)	CU NIPDAU	Level-1-260C-UNLIM
SN74LS156D	ACTIVE	SOIC	D	16	40	Green (RoHS & no Sb/Br)	CU NIPDAU	Level-1-260C-UNLIM
SN74LS156DE4	ACTIVE	SOIC	D	16	40	Green (RoHS & no Sb/Br)	CU NIPDAU	Level-1-260C-UNLIM
SN74LS156DE4	ACTIVE	SOIC	D	16	40	Green (RoHS & no Sb/Br)	CU NIPDAU	Level-1-260C-UNLIM
SN74LS156DR	ACTIVE	SOIC	D	16	2500	Green (RoHS & no Sb/Br)	CU NIPDAU	Level-1-260C-UNLIM
SN74LS156DR	ACTIVE	SOIC	D	16	2500	Green (RoHS & no Sb/Br)	CU NIPDAU	Level-1-260C-UNLIM
SN74LS156DRE4	ACTIVE	SOIC	D	16	2500	Green (RoHS & no Sb/Br)	CU NIPDAU	Level-1-260C-UNLIM
SN74LS156DRE4	ACTIVE	SOIC	D	16	2500	Green (RoHS & no Sb/Br)	CU NIPDAU	Level-1-260C-UNLIM
SN74LS156N	ACTIVE	PDIP	N	16	25	Pb-Free (RoHS)	CU NIPDAU	Level-NC-NC-NC
SN74LS156N	ACTIVE	PDIP	N	16	25	Pb-Free (RoHS)	CU NIPDAU	Level-NC-NC-NC
SN74LS156N3	OBSOLETE	PDIP	N	16		TBD	Call TI	Call TI
SN74LS156N3	OBSOLETE	PDIP	N	16		TBD	Call TI	Call TI
SN74LS156NSR	ACTIVE	SO	NS	16	2000	Green (RoHS & no Sb/Br)	CU NIPDAU	Level-1-260C-UNLIM
SN74LS156NSR	ACTIVE	SO	NS	16	2000	Green (RoHS & no Sb/Br)	CU NIPDAU	Level-1-260C-UNLIM
SN74LS156NSRE4	ACTIVE	SO	NS	16	2000	Green (RoHS & no Sb/Br)	CU NIPDAU	Level-1-260C-UNLIM
SN74LS156NSRE4	ACTIVE	SO	NS	16	2000	Green (RoHS & no Sb/Br)	CU NIPDAU	Level-1-260C-UNLIM
SNJ54155J	OBSOLETE	CDIP	J	16		TBD	Call TI	Call TI
SNJ54155J	OBSOLETE	CDIP	J	16		TBD	Call TI	Call TI
SNJ54155W	OBSOLETE	CFP	W	16		TBD	Call TI	Call TI
SNJ54155W	OBSOLETE	CFP	W	16		TBD	Call TI	Call TI
SNJ54LS155AFK	ACTIVE	LCCC	FK	20	1	TBD	Call TI	Level-NC-NC-NC
SNJ54LS155AFK	ACTIVE	LCCC	FK	20	1	TBD	Call TI	Level-NC-NC-NC
SNJ54LS155AJ	ACTIVE	CDIP	J	16	1	TBD	Call TI	Level-NC-NC-NC
SNJ54LS155AJ	ACTIVE	CDIP	J	16	1	TBD	Call TI	Level-NC-NC-NC
SNJ54LS155AW	ACTIVE	CFP	W	16	1	TBD	Call TI	Level-NC-NC-NC
SNJ54LS155AW	ACTIVE	CFP	W	16	1	TBD	Call TI	Level-NC-NC-NC
SNJ54LS156FK	OBSOLETE	LCCC	FK	20		TBD	Call TI	Call TI
SNJ54LS156FK	OBSOLETE	LCCC	FK	20		TBD	Call TI	Call TI
SNJ54LS156J	ACTIVE	CDIP	J	16	1	TBD	Call TI	Level-NC-NC-NC
SNJ54LS156J	ACTIVE	CDIP	J	16	1	TBD	Call TI	Level-NC-NC-NC
SNJ54LS156W	ACTIVE	CFP	W	16	1	TBD	Call TI	Level-NC-NC-NC

Orderable Device	Status ⁽¹⁾	Package Type	Package Drawing	Pins	Package Qty	Eco Plan ⁽²⁾	Lead/Ball Finish	MSL Peak Temp ⁽³⁾
SNJ54LS156W	ACTIVE	CFP	W	16	1	TBD	Call TI	Level-NC-NC-NC

⁽¹⁾ The marketing status values are defined as follows:

ACTIVE: Product device recommended for new designs.

LIFEBUY: TI has announced that the device will be discontinued, and a lifetime-buy period is in effect.

NRND: Not recommended for new designs. Device is in production to support existing customers, but TI does not recommend using this part in a new design.

PREVIEW: Device has been announced but is not in production. Samples may or may not be available.

OBSELETE: TI has discontinued the production of the device.

⁽²⁾ Eco Plan - The planned eco-friendly classification: Pb-Free (RoHS) or Green (RoHS & no Sb/Br) - please check <http://www.ti.com/productcontent> for the latest availability information and additional product content details.

TBD: The Pb-Free/Green conversion plan has not been defined.

Pb-Free (RoHS): TI's terms "Lead-Free" or "Pb-Free" mean semiconductor products that are compatible with the current RoHS requirements for all 6 substances, including the requirement that lead not exceed 0.1% by weight in homogeneous materials. Where designed to be soldered at high temperatures, TI Pb-Free products are suitable for use in specified lead-free processes.

Green (RoHS & no Sb/Br): TI defines "Green" to mean Pb-Free (RoHS compatible), and free of Bromine (Br) and Antimony (Sb) based flame retardants (Br or Sb do not exceed 0.1% by weight in homogeneous material)

⁽³⁾ MSL, Peak Temp. -- The Moisture Sensitivity Level rating according to the JEDEC industry standard classifications, and peak solder temperature.

Important Information and Disclaimer:The information provided on this page represents TI's knowledge and belief as of the date that it is provided. TI bases its knowledge and belief on information provided by third parties, and makes no representation or warranty as to the accuracy of such information. Efforts are underway to better integrate information from third parties. TI has taken and continues to take reasonable steps to provide representative and accurate information but may not have conducted destructive testing or chemical analysis on incoming materials and chemicals. TI and TI suppliers consider certain information to be proprietary, and thus CAS numbers and other limited information may not be available for release.

In no event shall TI's liability arising out of such information exceed the total purchase price of the TI part(s) at issue in this document sold by TI to Customer on an annual basis.

J (R-GDIP-T**)

14 LEADS SHOWN

CERAMIC DUAL IN-LINE PACKAGE

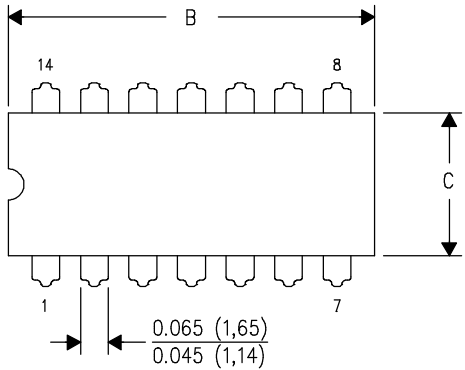

DIM \ PINS **	14	16	18	20
A	0.300 (7,62) BSC	0.300 (7,62) BSC	0.300 (7,62) BSC	0.300 (7,62) BSC
B MAX	0.785 (19,94)	.840 (21,34)	0.960 (24,38)	1.060 (26,92)
B MIN	—	—	—	—
C MAX	0.300 (7,62)	0.300 (7,62)	0.310 (7,87)	0.300 (7,62)
C MIN	0.245 (6,22)	0.245 (6,22)	0.220 (5,59)	0.245 (6,22)

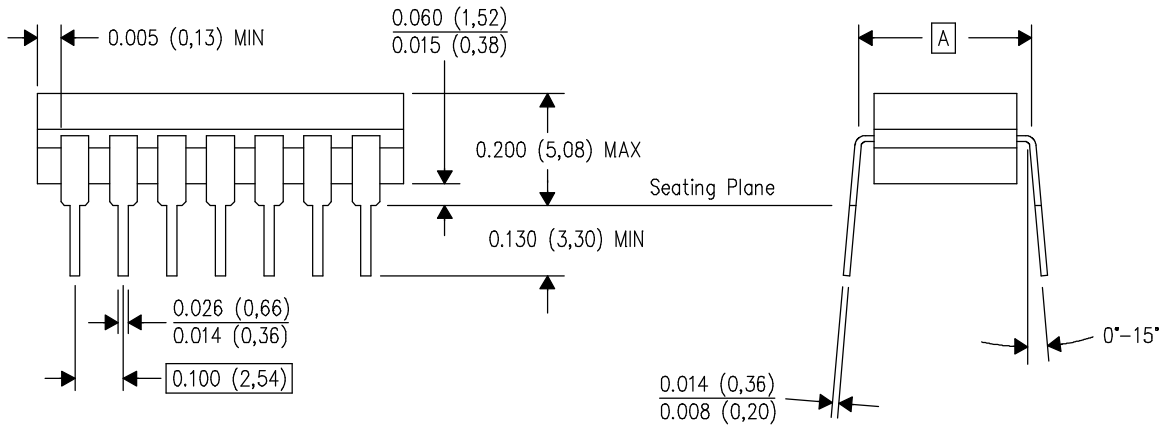

4040083/F 03/03

- NOTES:
- A. All linear dimensions are in inches (millimeters).
 - B. This drawing is subject to change without notice.
 - C. This package is hermetically sealed with a ceramic lid using glass frit.
 - D. Index point is provided on cap for terminal identification only on press ceramic glass frit seal only.
 - E. Falls within MIL STD 1835 GDIP1-T14, GDIP1-T16, GDIP1-T18 and GDIP1-T20.

MECHANICAL DATA

W (R-GDFP-F16)

CERAMIC DUAL FLATPACK

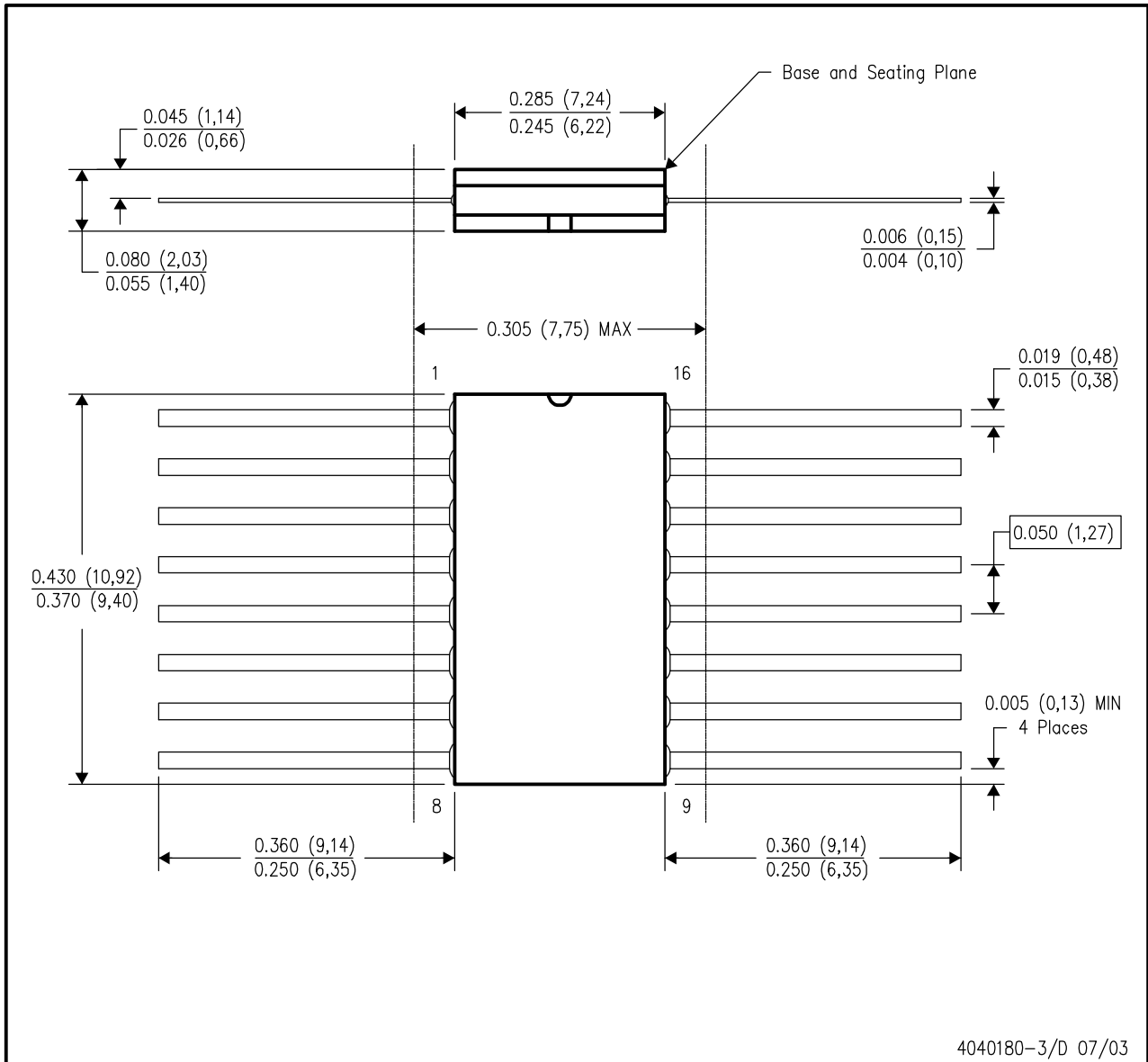

- NOTES:
- All linear dimensions are in inches (millimeters).
 - This drawing is subject to change without notice.
 - This package can be hermetically sealed with a ceramic lid using glass frit.
 - Index point is provided on cap for terminal identification only.
 - Falls within MIL STD 1835 GDFP1-F16 and JEDEC MO-092AC

MECHANICAL DATA

MLCC006B – OCTOBER 1996

FK (S-CQCC-N**)

LEADLESS CERAMIC CHIP CARRIER

28 TERMINAL SHOWN

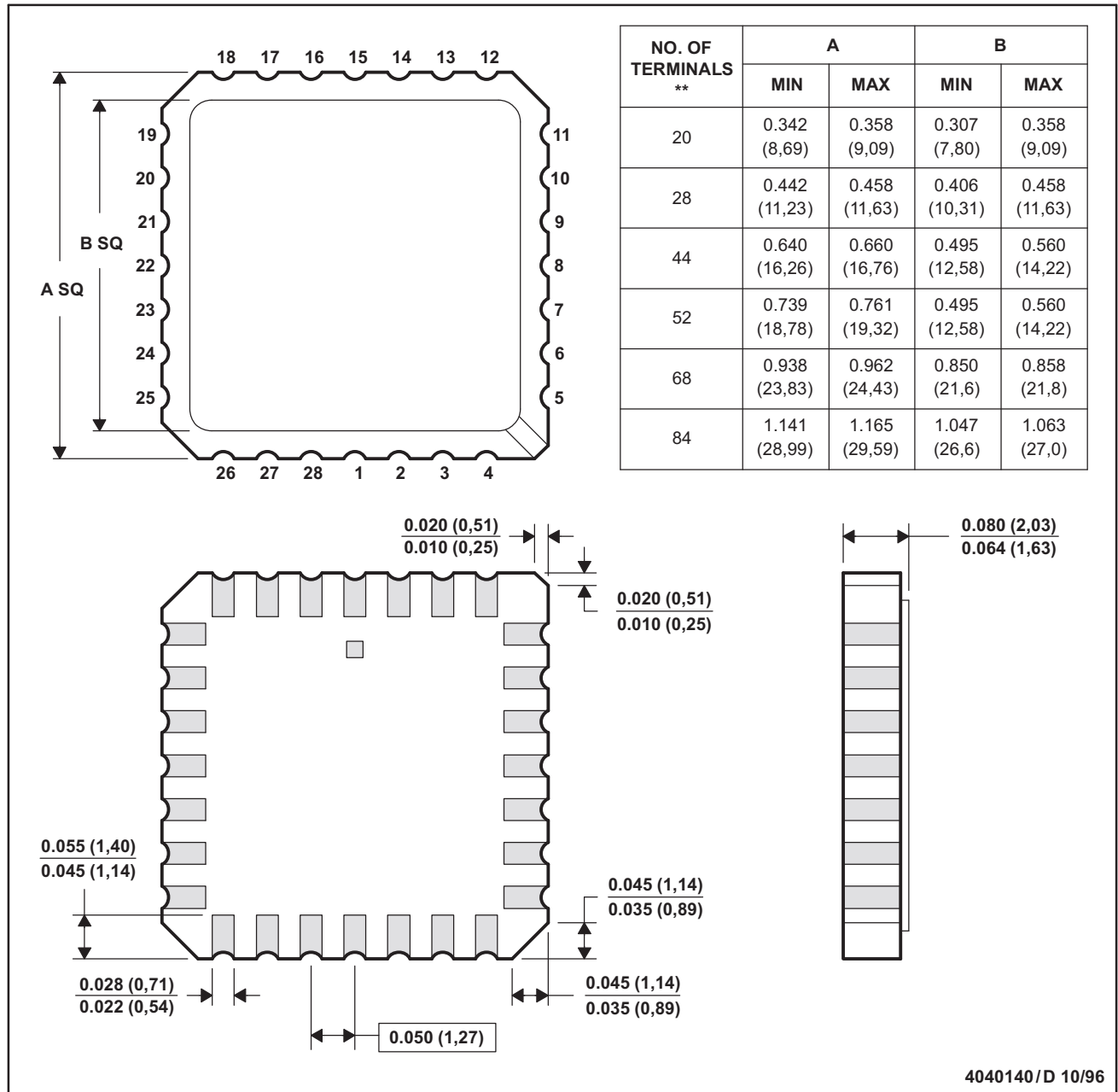

- NOTES:
- All linear dimensions are in inches (millimeters).
 - This drawing is subject to change without notice.
 - This package can be hermetically sealed with a metal lid.
 - The terminals are gold plated.
 - Falls within JEDEC MS-004

 **TEXAS
INSTRUMENTS**

POST OFFICE BOX 655303 • DALLAS, TEXAS 75265

MECHANICAL DATA

N (R-PDIP-T**)

16 PINS SHOWN

PLASTIC DUAL-IN-LINE PACKAGE

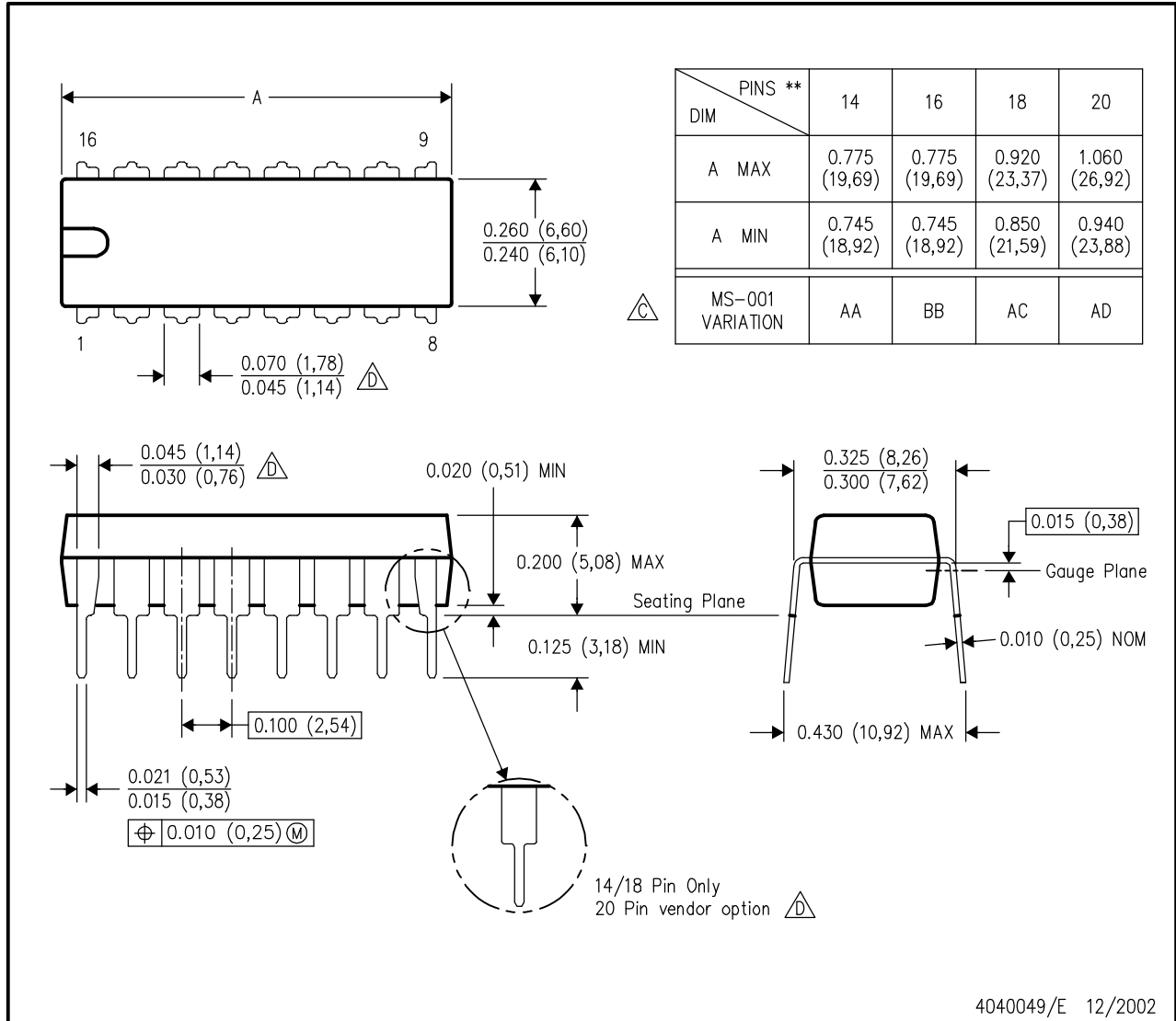

- NOTES:
- A. All linear dimensions are in inches (millimeters).
 - B. This drawing is subject to change without notice.
 - Falls within JEDEC MS-001, except 18 and 20 pin minimum body length (Dim A).
 - The 20 pin end lead shoulder width is a vendor option, either half or full width.

MECHANICAL DATA

D (R-PDSO-G16)

PLASTIC SMALL-OUTLINE PACKAGE

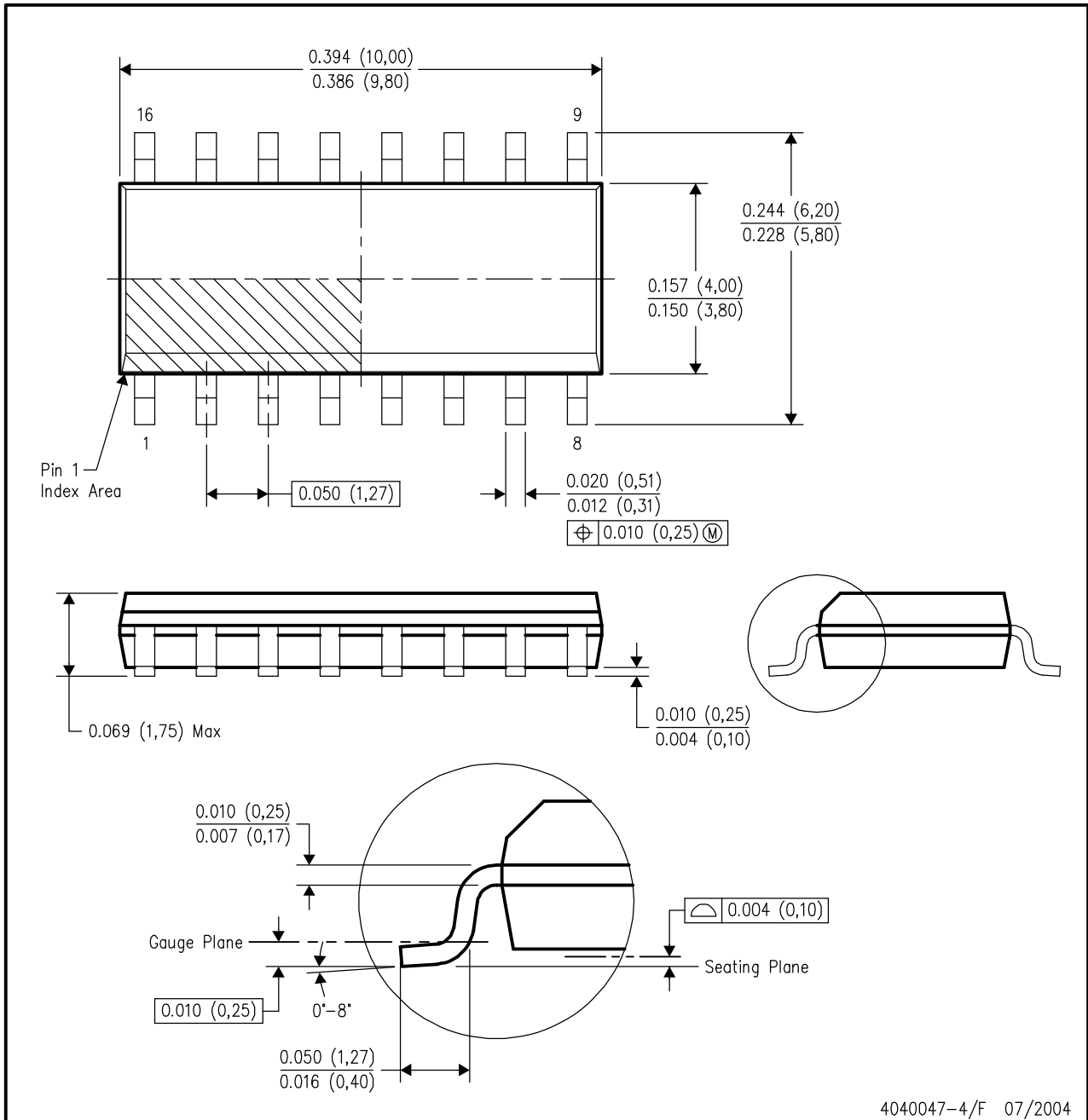

4040047-4/F 07/2004

- NOTES:
- All linear dimensions are in inches (millimeters).
 - This drawing is subject to change without notice.
 - Body dimensions do not include mold flash or protrusion not to exceed 0.006 (0,15).
 - Falls within JEDEC MS-012 variation AC.

MECHANICAL DATA

NS (R-PDSO-G)**

PLASTIC SMALL-OUTLINE PACKAGE

14-PINS SHOWN

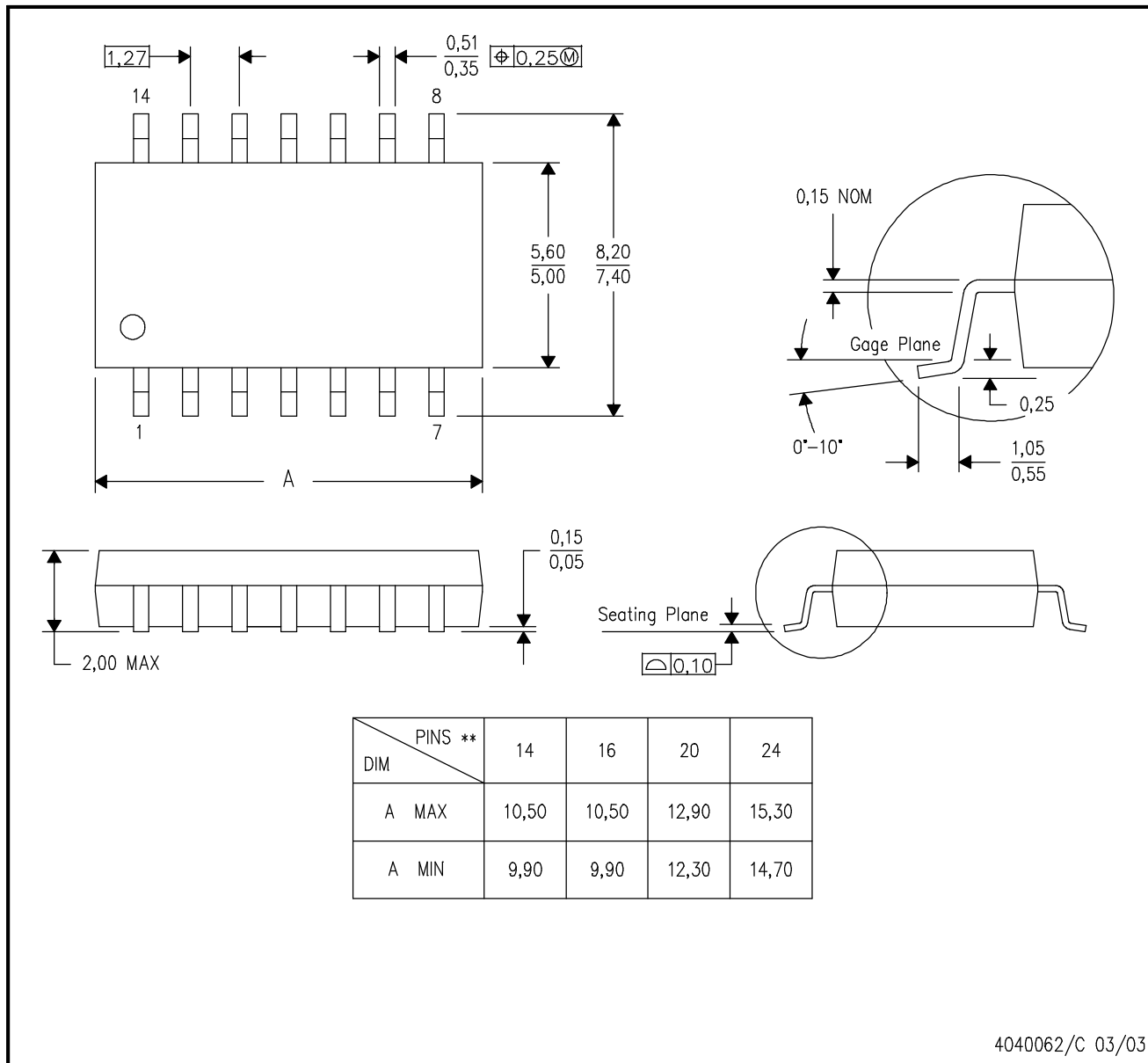

- NOTES:
- A. All linear dimensions are in millimeters.
 - B. This drawing is subject to change without notice.
 - C. Body dimensions do not include mold flash or protrusion, not to exceed 0,15.

IMPORTANT NOTICE

Texas Instruments Incorporated and its subsidiaries (TI) reserve the right to make corrections, modifications, enhancements, improvements, and other changes to its products and services at any time and to discontinue any product or service without notice. Customers should obtain the latest relevant information before placing orders and should verify that such information is current and complete. All products are sold subject to TI's terms and conditions of sale supplied at the time of order acknowledgment.

TI warrants performance of its hardware products to the specifications applicable at the time of sale in accordance with TI's standard warranty. Testing and other quality control techniques are used to the extent TI deems necessary to support this warranty. Except where mandated by government requirements, testing of all parameters of each product is not necessarily performed.

TI assumes no liability for applications assistance or customer product design. Customers are responsible for their products and applications using TI components. To minimize the risks associated with customer products and applications, customers should provide adequate design and operating safeguards.

TI does not warrant or represent that any license, either express or implied, is granted under any TI patent right, copyright, mask work right, or other TI intellectual property right relating to any combination, machine, or process in which TI products or services are used. Information published by TI regarding third-party products or services does not constitute a license from TI to use such products or services or a warranty or endorsement thereof. Use of such information may require a license from a third party under the patents or other intellectual property of the third party, or a license from TI under the patents or other intellectual property of TI.

Reproduction of information in TI data books or data sheets is permissible only if reproduction is without alteration and is accompanied by all associated warranties, conditions, limitations, and notices. Reproduction of this information with alteration is an unfair and deceptive business practice. TI is not responsible or liable for such altered documentation.

Resale of TI products or services with statements different from or beyond the parameters stated by TI for that product or service voids all express and any implied warranties for the associated TI product or service and is an unfair and deceptive business practice. TI is not responsible or liable for any such statements.

Following are URLs where you can obtain information on other Texas Instruments products and application solutions:

Products		Applications	
Amplifiers	amplifier.ti.com	Audio	www.ti.com/audio
Data Converters	dataconverter.ti.com	Automotive	www.ti.com/automotive
DSP	dsp.ti.com	Broadband	www.ti.com/broadband
Interface	interface.ti.com	Digital Control	www.ti.com/digitalcontrol
Logic	logic.ti.com	Military	www.ti.com/military
Power Mgmt	power.ti.com	Optical Networking	www.ti.com/opticalnetwork
Microcontrollers	microcontroller.ti.com	Security	www.ti.com/security
		Telephony	www.ti.com/telephony
		Video & Imaging	www.ti.com/video
		Wireless	www.ti.com/wireless

Mailing Address: Texas Instruments
Post Office Box 655303 Dallas, Texas 75265

Copyright © 2005, Texas Instruments Incorporated