

SN5414, SN54LS14, SN7414, SN74LS14 HEX SCHMITT-TRIGGER INVERTERS

SDLS049B – DECEMBER 1983 – REVISED FEBRUARY 2002

- Operation From Very Slow Edges
- Improved Line-Receiving Characteristics
- High Noise Immunity

description

Each circuit functions as an inverter, but because of the Schmitt action, it has different input threshold levels for positive-going (V_{T+}) and negative-going (V_{T-}) signals.

These circuits are temperature compensated and can be triggered from the slowest of input ramps and still give clean, jitter-free output signals.

SN5414, SN54LS14 . . . J OR W PACKAGE
SN7414 . . . D, N, OR NS PACKAGE
SN74LS14 . . . D, DB, OR N PACKAGE

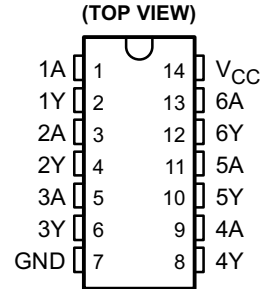

SN54LS14 . . . FK PACKAGE
(TOP VIEW)

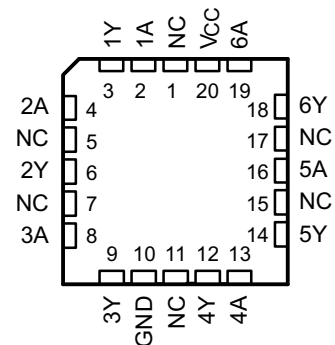

NC – No internal connection

ORDERING INFORMATION

T_A	PACKAGE†		ORDERABLE PART NUMBER	TOP-SIDE MARKING
0°C to 70°C	PDIP – N	Tube	SN7414N	SN7414N
		Tube	SN74LS14N	SN74LS14N
	SOIC – D	Tube	SN7414D	7414
		Tape and reel	SN7414DR	
		Tube	SN74LS14D	LS14
	Tape and reel	SN74LS14DR		
	SOP – NS	Tape and reel	SN7414NSR	SN7414
SSOP – DB	Tape and reel	SN74LS14DBR	LS14	
–55°C to 125°C	CDIP – J	Tube	SN5414J	SN5414J
		Tube	SNJ5414J	SNJ5414J
		Tube	SN54LS14J	SN54LS14J
		Tube	SNJ54LS14J	SNJ54LS14J
	CFP – W	Tube	SNJ5414W	SNJ5414W
		Tube	SNJ54LS14W	SNJ54LS14W
LCCC – FK	Tube	SNJ54LS14FK	SNJ54LS14FK	

† Package drawings, standard packing quantities, thermal data, symbolization, and PCB design guidelines are available at www.ti.com/sc/package.



Please be aware that an important notice concerning availability, standard warranty, and use in critical applications of Texas Instruments semiconductor products and disclaimers thereto appears at the end of this data sheet.

PRODUCTION DATA information is current as of publication date. Products conform to specifications per the terms of Texas Instruments standard warranty. Production processing does not necessarily include testing of all parameters.

 **TEXAS
INSTRUMENTS**

POST OFFICE BOX 655303 • DALLAS, TEXAS 75265

Copyright © 2002, Texas Instruments Incorporated
On products compliant to MIL-PRF-38535, all parameters are tested unless otherwise noted. On all other products, production processing does not necessarily include testing of all parameters.

**SN5414, SN54LS14,
SN7414, SN74LS14**
HEX SCHMITT-TRIGGER INVERTERS
SDLS049B – DECEMBER 1983 – REVISED FEBRUARY 2002

logic diagram (positive logic)

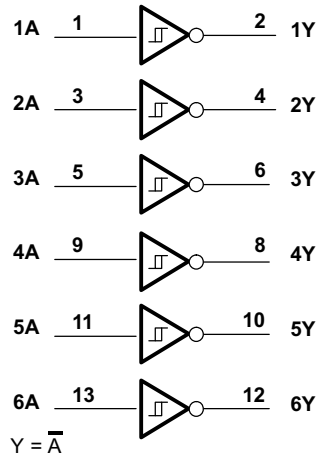

Pin numbers shown are for the D, DB, J, N, NS, and W packages.

schematic

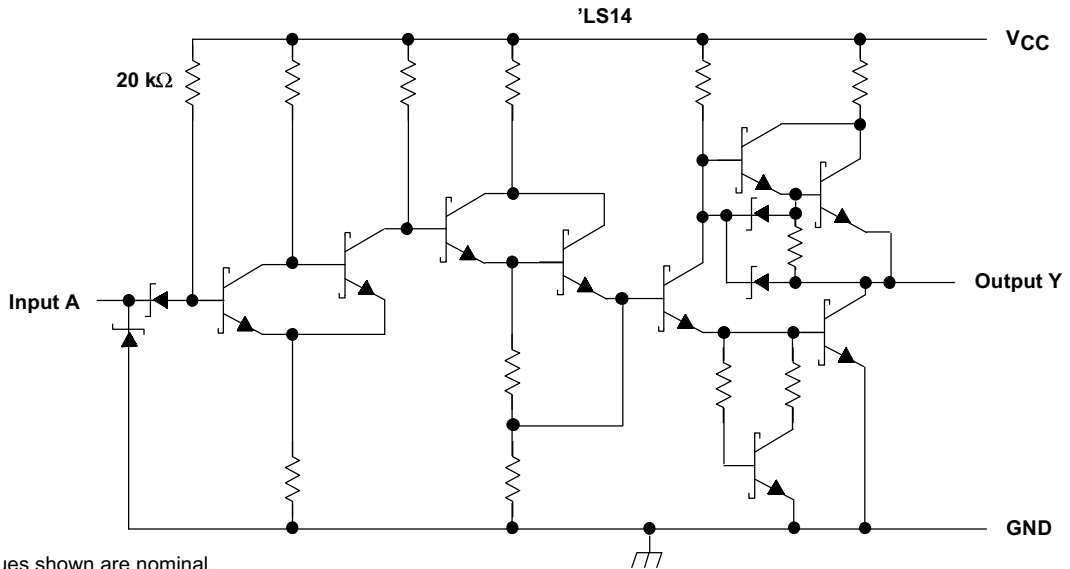
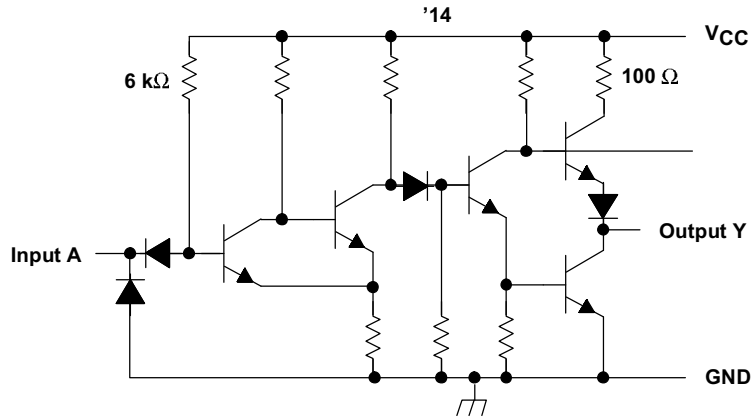

Resistor values shown are nominal.

**SN5414, SN54LS14,
SN7414, SN74LS14**
HEX SCHMITT-TRIGGER INVERTERS

SDLS049B – DECEMBER 1983 – REVISED FEBRUARY 2002

absolute maximum ratings over operating free-air temperature (unless otherwise noted)†

Supply voltage, V_{CC} (see Note 1)	7 V
Input voltage: '14	5.5 V
'LS14	7 V
Package thermal impedance, θ_{JA} (see Note 2): D package	86°C/W
DB package	96°C/W
N package	80°C/W
NS package	76°C/W
Storage temperature range, T_{stg}	-65°C to 150°C

† Stresses beyond those listed under “absolute maximum ratings” may cause permanent damage to the device. These are stress ratings only, and functional operation of the device at these or any other conditions beyond those indicated under “recommended operating conditions” is not implied. Exposure to absolute-maximum-rated conditions for extended periods may affect device reliability.

- NOTES: 1. Voltage values are with respect to network ground terminal.
2. The package thermal impedance is calculated in accordance with JESD 51-7

recommended operating conditions

		SN5414			SN7414			UNIT
		MIN	NOM	MAX	MIN	NOM	MAX	
V_{CC}	Supply voltage	4.5	5	5.5	4.75	5	5.25	V
I_{OH}	High-level output current			-0.8			-0.8	mA
I_{OL}	Low-level output current			16			16	mA
T_A	Operating free-air temperature	-55		125	0		70	°C

electrical characteristics over recommended operating free-air temperature range (unless otherwise noted)

PARAMETER	TEST CONDITIONS‡	SN5414 SN7414			UNIT
		MIN	TYP§	MAX	
V_{T+}	$V_{CC} = 5 V$	1.5	1.7	2	V
V_{T-}	$V_{CC} = 5 V$	0.6	0.9	1.1	V
Hysteresis ($V_{T+} - V_{T-}$)	$V_{CC} = 5 V$	0.4	0.8		V
V_{IK}	$V_{CC} = \text{MIN}, I_I = -12 \text{ mA}$			-1.5	V
V_{OH}	$V_{CC} = \text{MIN}, V_I = 0.6 V, I_{OH} = -0.8 \text{ mA}$	2.4	3.4		V
V_{OL}	$V_{CC} = \text{MIN}, V_I = 2 V, I_{OL} = 16 \text{ mA}$		0.2	0.4	V
I_{T+}	$V_{CC} = 5 V, V_I = V_{T+}$		-0.43		mA
I_{T-}	$V_{CC} = 5 V, V_I = V_{T-}$		-0.56		mA
I_I	$V_{CC} = \text{MAX}, V_I = 5.5 V$			1	mA
I_{IH}	$V_{CC} = \text{MAX}, V_{IH} = 2.4 V$			40	µA
I_{IL}	$V_{CC} = \text{MAX}, V_{IL} = 0.4 V$		-0.8	-1.2	mA
$I_{OS}\ \ $	$V_{CC} = \text{MAX}$	-18		-55	mA
I_{CCH}	$V_{CC} = \text{MAX}$		22	36	mA
I_{CCL}	$V_{CC} = \text{MAX}$		39	60	mA

‡ For conditions shown as MIN or MAX, use the appropriate value specified under recommended operating conditions.

§ All typical values are at $V_{CC} = 5 V, T_A = 25^\circ C$.

\|\| Not more than one output should be shorted at a time.



**SN5414, SN54LS14,
SN7414, SN74LS14**
HEX SCHMITT-TRIGGER INVERTERS
SDLS049B – DECEMBER 1983 – REVISED FEBRUARY 2002

switching characteristics, $V_{CC} = 5\text{ V}$, $T_A = 25^\circ\text{C}$ (see Figure 1)

PARAMETER	FROM (INPUT)	TO (OUTPUT)	TEST CONDITIONS	SN5414 SN7414			UNIT
				MIN	TYP	MAX	
t_{PLH}	A	Y	$R_L = 400\ \Omega$, $C_L = 15\ \text{pF}$		15	22	ns
t_{PHL}					15	22	

recommended operating conditions

		SN54LS14			SN74LS14			UNIT
		MIN	NOM	MAX	MIN	NOM	MAX	
V_{CC}	Supply voltage	4.5	5	5.5	4.75	5	5.25	V
I_{OH}	High-level output current			-0.4			-0.4	mA
I_{OL}	Low-level output current			4			8	mA
T_A	Operating free-air temperature	-55		125	0		70	$^\circ\text{C}$

electrical characteristics over recommended operating free-air temperature range (unless otherwise noted)

PARAMETER	TEST CONDITIONS†	SN54LS14			SN74LS14			UNIT	
		MIN	TYP‡	MAX	MIN	TYP‡	MAX		
V_{T+}	$V_{CC} = 5\text{ V}$	1.4	1.6	1.9	1.4	1.6	1.9	V	
V_{T-}	$V_{CC} = 5\text{ V}$	0.5	0.8	1	0.5	0.8	1	V	
Hysteresis ($V_{T+} - V_{T-}$)	$V_{CC} = 5\text{ V}$	0.4	0.8		0.4	0.8		V	
V_{IK}	$V_{CC} = \text{MIN}$, $I_I = -18\ \text{mA}$			-1.5			-1.5	V	
V_{OH}	$V_{CC} = \text{MIN}$, $V_I = 0.5\text{ V}$, $I_{OH} = -0.4\ \text{mA}$	2.5	3.4		2.7	3.4		V	
V_{OL}	$V_{CC} = \text{MIN}$, $V_I = -1.9\text{ V}$	$I_{OL} = 4\ \text{mA}$		0.25	0.4	$I_{OL} = 4\ \text{mA}$		0.25	0.4
		$I_{OL} = 8\ \text{mA}$				$I_{OL} = 8\ \text{mA}$		0.35	0.5
I_{T+}	$V_{CC} = 5\text{ V}$, $V_I = V_{T+}$		-0.14			-0.14		mA	
I_{T-}	$V_{CC} = 5\text{ V}$, $V_I = V_{T-}$		-0.18			-0.18		mA	
I_I	$V_{CC} = \text{MAX}$, $V_I = 7\text{ V}$			0.1			0.1	mA	
I_{IH}	$V_{CC} = \text{MAX}$, $V_{IH} = 2.7\text{ V}$			20			20	μA	
I_{IL}	$V_{CC} = \text{MAX}$, $V_{IL} = 0.4\text{ V}$			-0.4			-0.4	mA	
I_{OS}^{\S}	$V_{CC} = \text{MAX}$	-20		-100	-20		-100	mA	
I_{CCH}	$V_{CC} = \text{MAX}$		8.6	16		8.6	16	mA	
I_{CCL}	$V_{CC} = \text{MAX}$		12	21		12	21	mA	

† For conditions shown as MIN or MAX, use the appropriate value specified under recommended operating conditions.

‡ All typical values are at $V_{CC} = 5\text{ V}$, $T_A = 25^\circ\text{C}$.

§ Not more than one output should be shorted at a time, and duration of the short-circuit should not exceed one second.

switching characteristics, $V_{CC} = 5\text{ V}$, $T_A = 25^\circ\text{C}$ (see Figure 2)

PARAMETER	FROM (INPUT)	TO (OUTPUT)	TEST CONDITIONS	MIN	TYP	MAX	UNIT
t_{PLH}	A	Y	$R_L = 2\ \text{k}\Omega$, $C_L = 15\ \text{pF}$		15	22	ns
t_{PHL}					15	22	



PARAMETER MEASUREMENT INFORMATION
SERIES 54/74 DEVICES

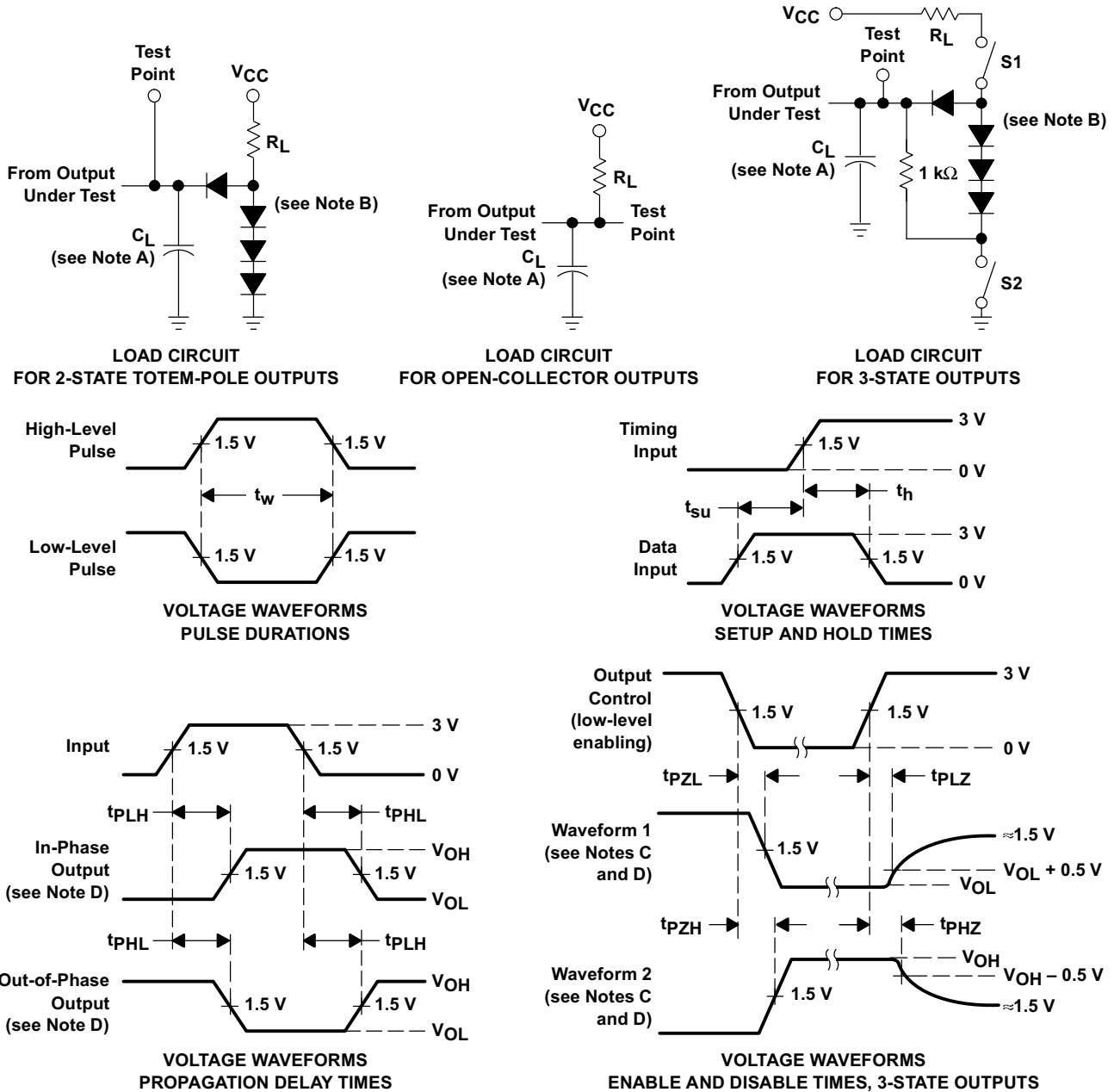

- NOTES: A. C_L includes probe and jig capacitance.
B. All diodes are 1N3064 or equivalent.
C. Waveform 1 is for an output with internal conditions such that the output is low except when disabled by the output control. Waveform 2 is for an output with internal conditions such that the output is high except when disabled by the output control.
D. S1 and S2 are closed for t_{PLH} , t_{PHL} , t_{PHZ} , and t_{PLZ} ; S1 is open and S2 is closed for t_{PZH} ; S1 is closed and S2 is open for t_{PZL} .
E. All input pulses are supplied by generators having the following characteristics: $PRR \leq 1$ MHz, $Z_O \approx 50 \Omega$; t_r and $t_f \leq 7$ ns for Series 54/74 devices and t_r and $t_f \leq 2.5$ ns for Series 54S/74S devices.
F. The outputs are measured one at a time with one input transition per measurement.

Figure 1. Load Circuits and Voltage Waveforms

PARAMETER MEASUREMENT INFORMATION
SERIES 54LS/74LS DEVICES

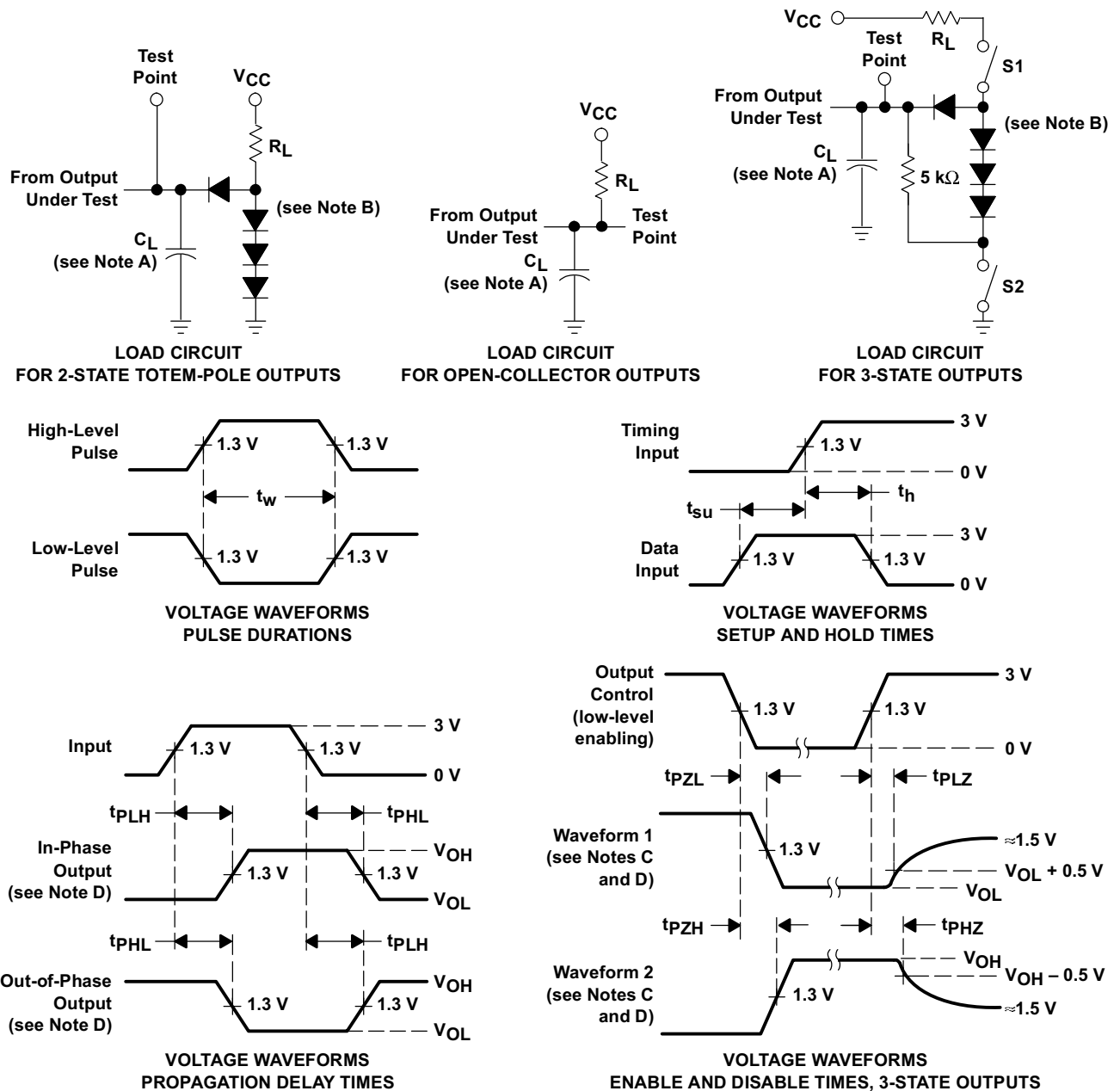

- NOTES: A. C_L includes probe and jig capacitance.
 B. All diodes are 1N3064 or equivalent.
 C. Waveform 1 is for an output with internal conditions such that the output is low except when disabled by the output control. Waveform 2 is for an output with internal conditions such that the output is high except when disabled by the output control.
 D. S1 and S2 are closed for t_{PLH} , t_{PHL} , t_{PHZ} , and t_{PZL} ; S1 is open and S2 is closed for t_{PZH} ; S1 is closed and S2 is open for t_{PZL} .
 E. Phase relationships between inputs and outputs have been chosen arbitrarily for these examples.
 F. All input pulses are supplied by generators having the following characteristics: $PRR \leq 1$ MHz, $Z_O \approx 50 \Omega$, $t_r \leq 1.5$ ns, $t_f \leq 2.6$ ns.
 G. The outputs are measured one at a time with one input transition per measurement.

Figure 2. Load Circuits and Voltage Waveforms

TYPICAL CHARACTERISTICS OF '14 CIRCUIT†

POSITIVE-GOING THRESHOLD VOLTAGE
 vs
 FREE-AIR TEMPERATURE

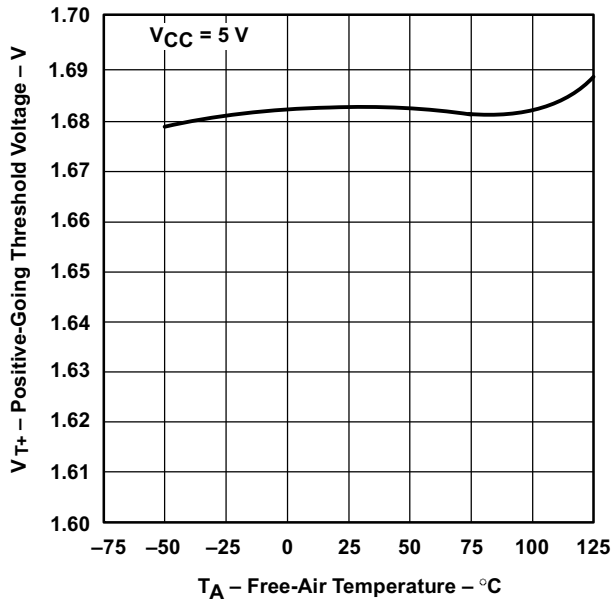

Figure 3

NEGATIVE-GOING THRESHOLD VOLTAGE
 vs
 FREE-AIR TEMPERATURE

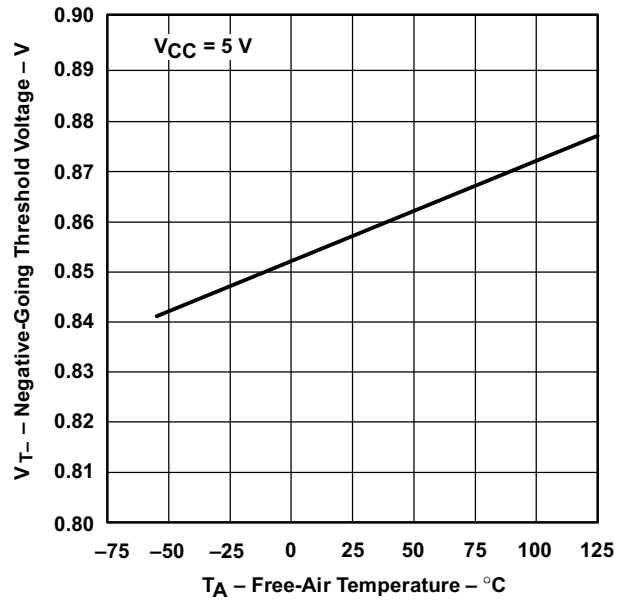

Figure 4

HYSTERESIS
 vs
 FREE-AIR TEMPERATURE

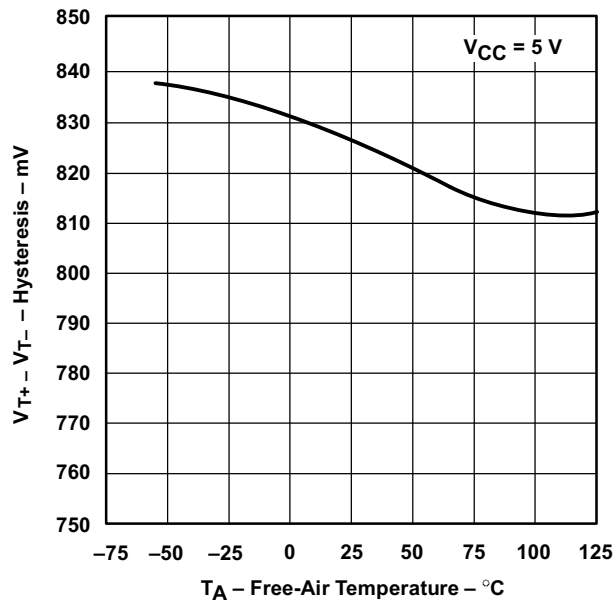

Figure 5

† Data for temperatures below 0°C and above 70°C and supply voltage below 4.75 V and above 5.25 V are applicable for SN5414 only.

TYPICAL CHARACTERISTICS OF '14 CIRCUITS†

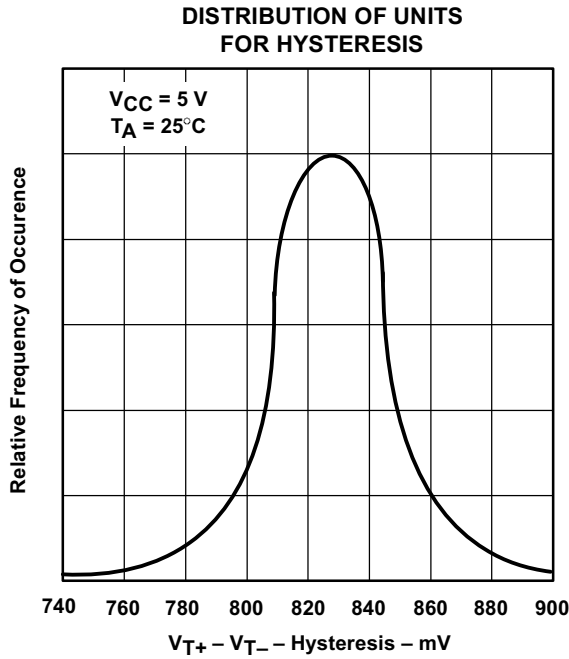

Figure 6

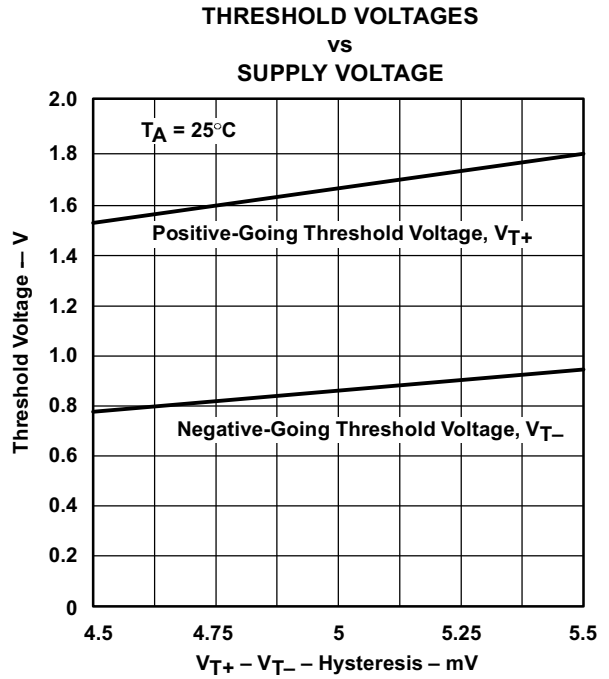

Figure 7

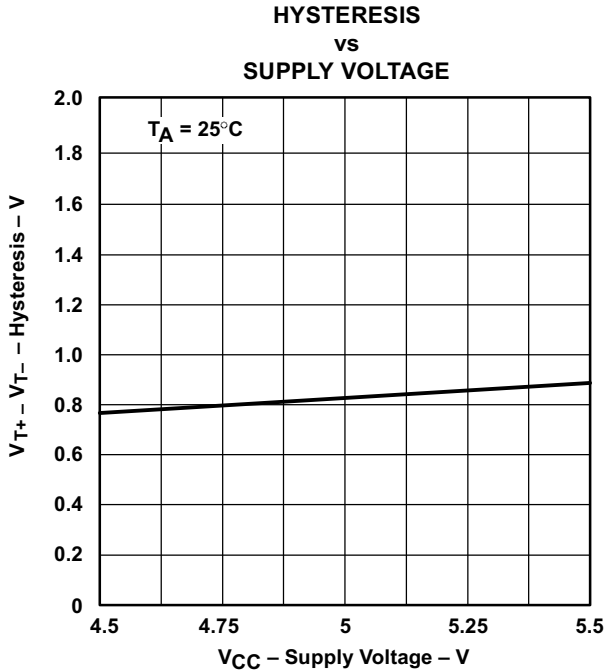

Figure 8

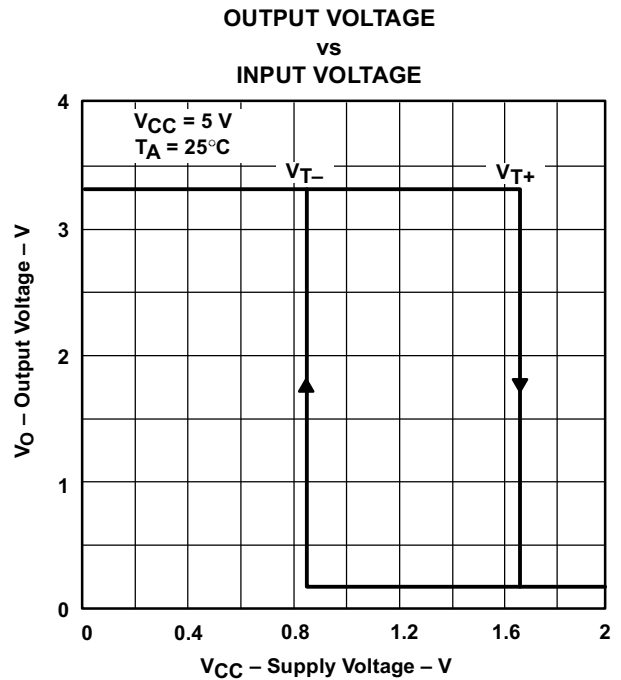

Figure 9

† Data for temperatures below 0°C and above 70°C and supply voltage below 4.75 V and above 5.25 V are applicable for SN5414 only.

**SN5414, SN54LS14,
SN7414, SN74LS14
HEX SCHMITT-TRIGGER INVERTERS**

SDLS049B – DECEMBER 1983 – REVISED FEBRUARY 2002

TYPICAL CHARACTERISTICS OF 'LS14 CIRCUITS†

**POSITIVE-GOING THRESHOLD VOLTAGE
vs
FREE-AIR TEMPERATURE**

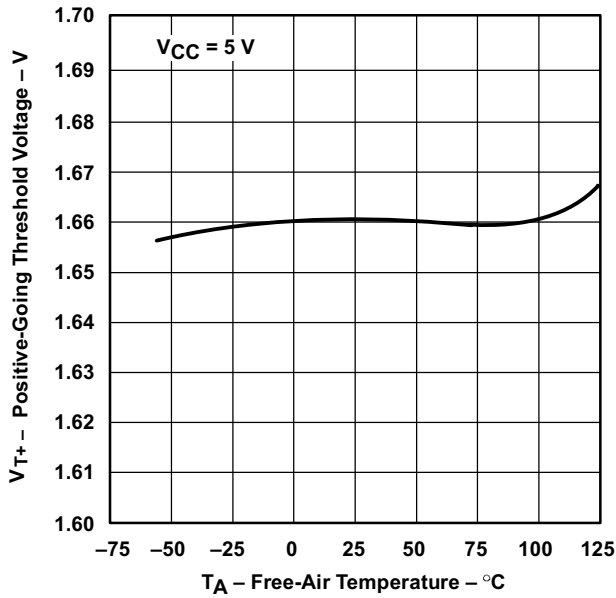

Figure 10

**NEGATIVE-GOING THRESHOLD VOLTAGE
vs
FREE-AIR TEMPERATURE**

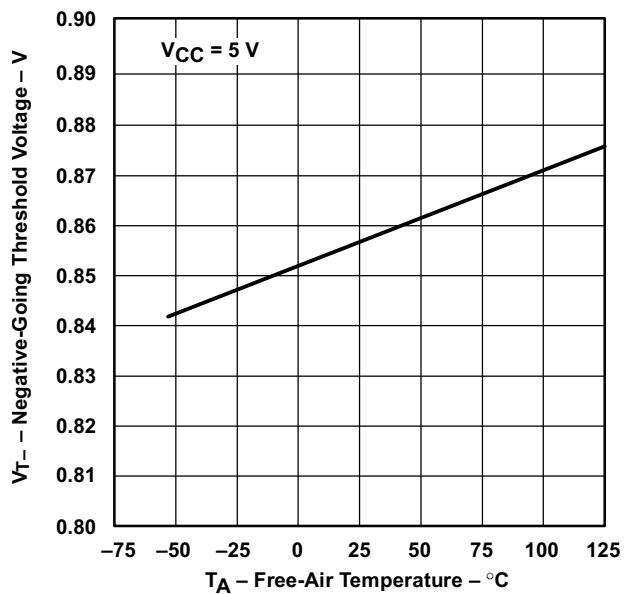

Figure 11

**HYSTERESIS
vs
FREE-AIR TEMPERATURE**

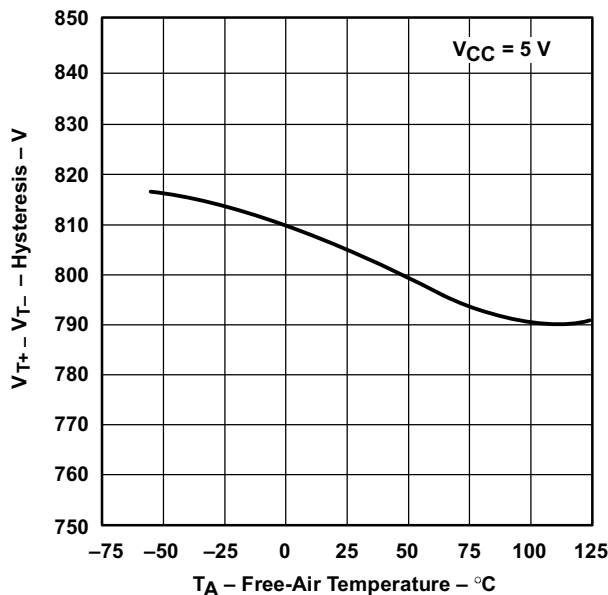

Figure 12

**DISTRIBUTION OF UNITS
FOR HYSTERESIS**

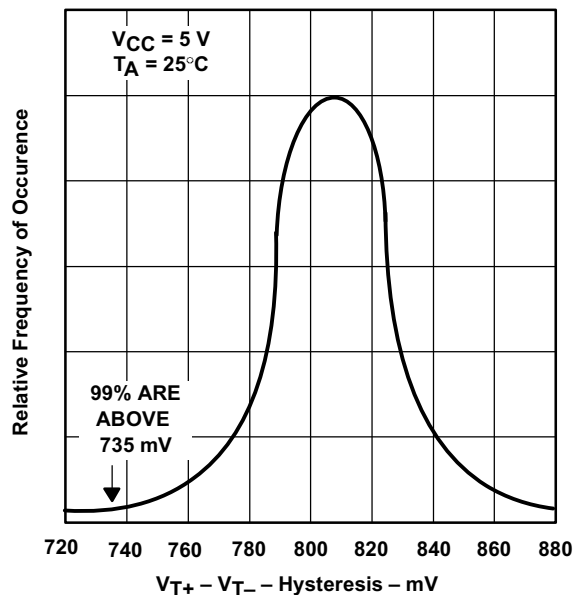

Figure 13

† Data for temperatures below 0°C and above 70°C and supply voltage below 4.75 V and above 5.25 V are applicable for SN5414 only.



TYPICAL CHARACTERISTICS OF 'LS14 CIRCUITS†

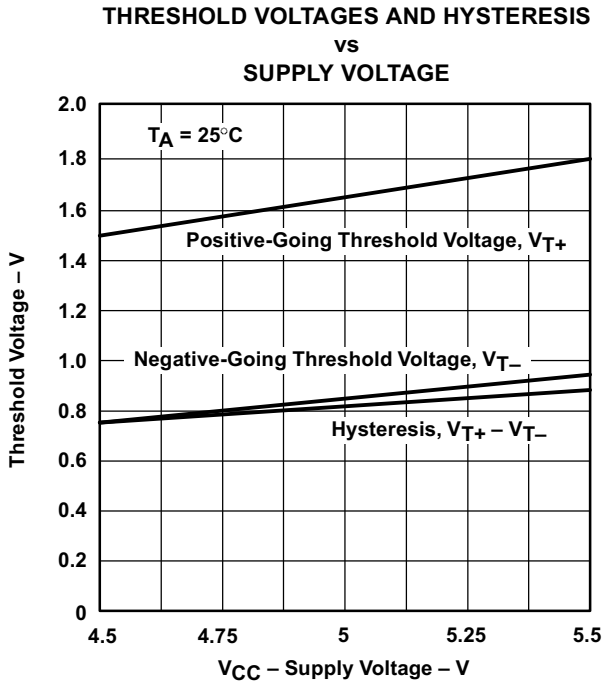

Figure 14

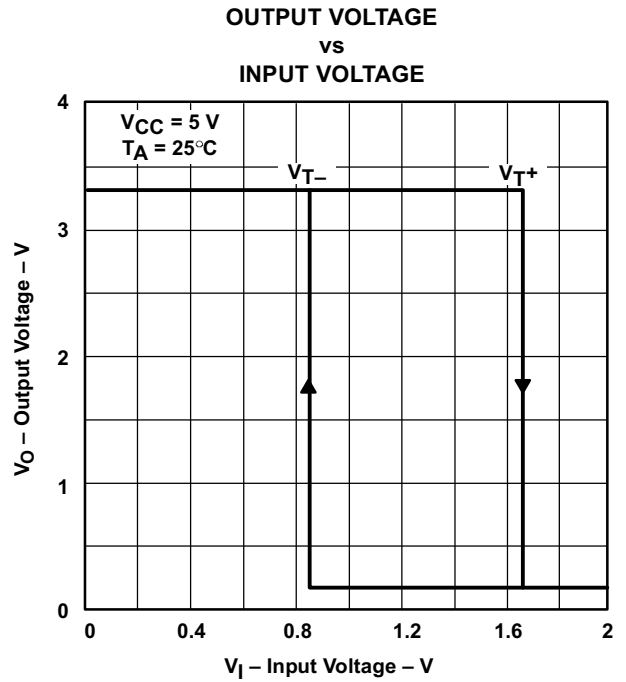

Figure 15

† Data for temperatures below 0°C and above 70°C and supply voltage below 4.75 V and above 5.25 V are applicable for SN5414 only.

**SN5414, SN54LS14,
SN7414, SN74LS14**
HEX SCHMITT-TRIGGER INVERTERS

SDLS049B – DECEMBER 1983 – REVISED FEBRUARY 2002

TYPICAL APPLICATION DATA

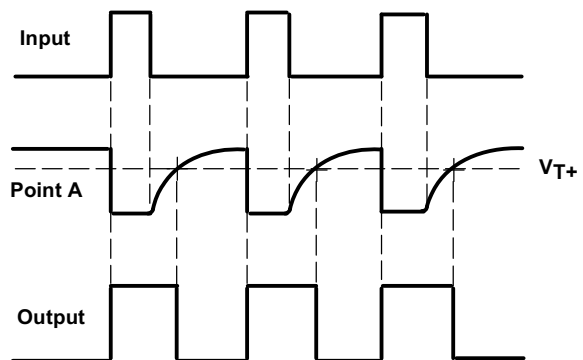
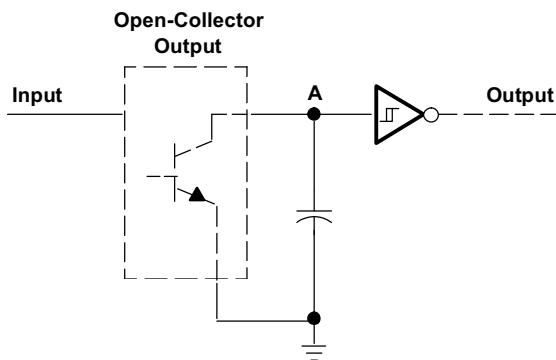
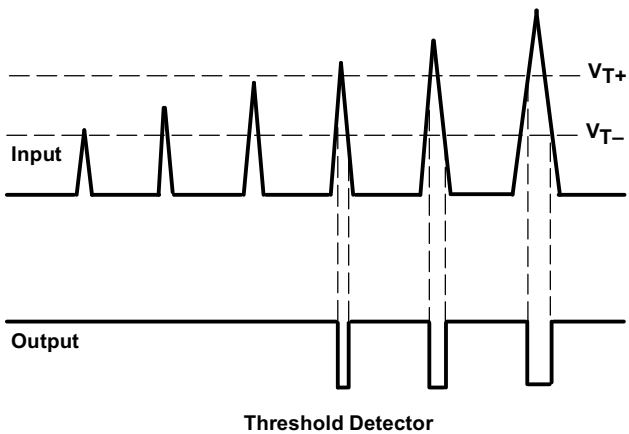
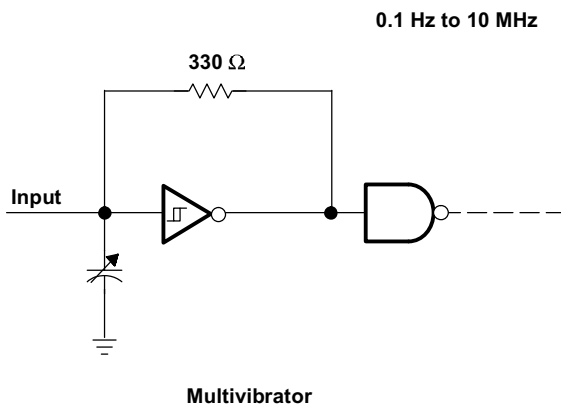
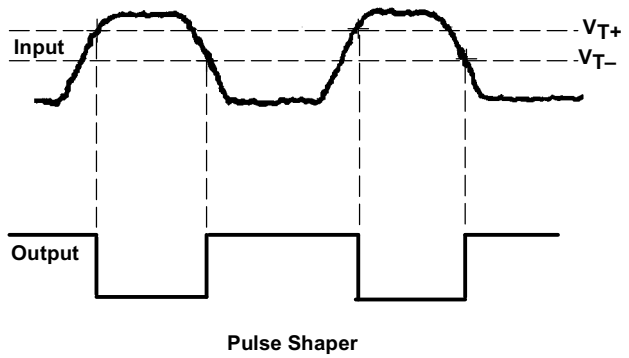
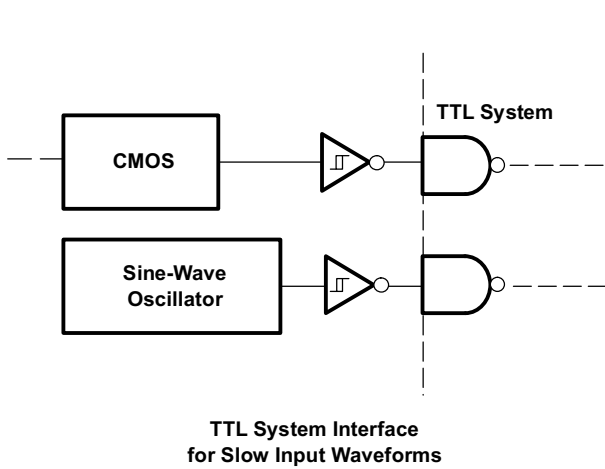

PACKAGING INFORMATION

Orderable Device	Status ⁽¹⁾	Package Type	Package Drawing	Pins	Package Qty	Eco Plan ⁽²⁾	Lead/Ball Finish	MSL Peak Temp ⁽³⁾
5962-9665801Q2A	ACTIVE	LCCC	FK	20	1	TBD	Call TI	Level-NC-NC-NC
5962-9665801QCA	ACTIVE	CDIP	J	14	1	TBD	Call TI	Level-NC-NC-NC
5962-9665801QDA	ACTIVE	CFP	W	14	1	TBD	Call TI	Level-NC-NC-NC
5962-9665801VCA	ACTIVE	CDIP	J	14	1	TBD	Call TI	Level-NC-NC-NC
5962-9665801VDA	ACTIVE	CFP	W	14	1	TBD	Call TI	Level-NC-NC-NC
JM38510/31302BCA	ACTIVE	CDIP	J	14	1	TBD	Call TI	Level-NC-NC-NC
SN5414J	ACTIVE	CDIP	J	14	1	TBD	Call TI	Level-NC-NC-NC
SN54LS14J	ACTIVE	CDIP	J	14	1	TBD	Call TI	Level-NC-NC-NC
SN7414D	ACTIVE	SOIC	D	14	50	Pb-Free (RoHS)	CU NIPDAU	Level-2-260C-1 YEAR/ Level-1-235C-UNLIM
SN7414DE4	ACTIVE	SOIC	D	14	50	Pb-Free (RoHS)	CU NIPDAU	Level-2-260C-1 YEAR/ Level-1-235C-UNLIM
SN7414DR	ACTIVE	SOIC	D	14	2500	Pb-Free (RoHS)	CU NIPDAU	Level-2-260C-1 YEAR/ Level-1-235C-UNLIM
SN7414DRE4	ACTIVE	SOIC	D	14	2500	Pb-Free (RoHS)	CU NIPDAU	Level-2-260C-1 YEAR/ Level-1-235C-UNLIM
SN7414N	ACTIVE	PDIP	N	14	25	Pb-Free (RoHS)	CU NIPDAU	Level-NC-NC-NC
SN7414N3	OBSOLETE	PDIP	N	14		TBD	Call TI	Call TI
SN7414NSR	ACTIVE	SO	NS	14	2000	Pb-Free (RoHS)	CU NIPDAU	Level-2-260C-1 YEAR/ Level-1-235C-UNLIM
SN7414NSRE4	ACTIVE	SO	NS	14	2000	Pb-Free (RoHS)	CU NIPDAU	Level-2-260C-1 YEAR/ Level-1-235C-UNLIM
SN74LS14D	ACTIVE	SOIC	D	14	50	Pb-Free (RoHS)	CU NIPDAU	Level-2-260C-1 YEAR/ Level-1-235C-UNLIM
SN74LS14DBR	ACTIVE	SSOP	DB	14	2000	Pb-Free (RoHS)	CU NIPDAU	Level-2-260C-1 YEAR/ Level-1-235C-UNLIM
SN74LS14DBRE4	ACTIVE	SSOP	DB	14	2000	Pb-Free (RoHS)	CU NIPDAU	Level-2-260C-1 YEAR/ Level-1-235C-UNLIM
SN74LS14DR	ACTIVE	SOIC	D	14	2500	Pb-Free (RoHS)	CU NIPDAU	Level-2-260C-1 YEAR/ Level-1-235C-UNLIM
SN74LS14N	ACTIVE	PDIP	N	14	25	Pb-Free (RoHS)	CU NIPDAU	Level-NC-NC-NC
SN74LS14N3	OBSOLETE	PDIP	N	14		TBD	Call TI	Call TI
SN74LS14NE4	ACTIVE	PDIP	N	14	25	TBD	Call TI	Call TI
SN74LS14NSRG4	ACTIVE	SO	NS	14	2000	Green (RoHS & no Sb/Br)	CU NIPDAU	Level-1-260C-UNLIM
SNJ5414J	ACTIVE	CDIP	J	14	1	TBD	Call TI	Level-NC-NC-NC
SNJ5414W	ACTIVE	CFP	W	14	1	TBD	Call TI	Level-NC-NC-NC
SNJ54LS14FK	ACTIVE	LCCC	FK	20	1	TBD	Call TI	Level-NC-NC-NC
SNJ54LS14J	ACTIVE	CDIP	J	14	1	TBD	Call TI	Level-NC-NC-NC
SNJ54LS14W	ACTIVE	CFP	W	14	1	TBD	Call TI	Level-NC-NC-NC

⁽¹⁾ The marketing status values are defined as follows:

ACTIVE: Product device recommended for new designs.

LIFEBUY: TI has announced that the device will be discontinued, and a lifetime-buy period is in effect.

NRND: Not recommended for new designs. Device is in production to support existing customers, but TI does not recommend using this part in a new design.

PREVIEW: Device has been announced but is not in production. Samples may or may not be available.
OBSOLETE: TI has discontinued the production of the device.

⁽²⁾ Eco Plan - The planned eco-friendly classification: Pb-Free (RoHS) or Green (RoHS & no Sb/Br) - please check <http://www.ti.com/productcontent> for the latest availability information and additional product content details.

TBD: The Pb-Free/Green conversion plan has not been defined.

Pb-Free (RoHS): TI's terms "Lead-Free" or "Pb-Free" mean semiconductor products that are compatible with the current RoHS requirements for all 6 substances, including the requirement that lead not exceed 0.1% by weight in homogeneous materials. Where designed to be soldered at high temperatures, TI Pb-Free products are suitable for use in specified lead-free processes.

Green (RoHS & no Sb/Br): TI defines "Green" to mean Pb-Free (RoHS compatible), and free of Bromine (Br) and Antimony (Sb) based flame retardants (Br or Sb do not exceed 0.1% by weight in homogeneous material)

⁽³⁾ MSL, Peak Temp. -- The Moisture Sensitivity Level rating according to the JEDEC industry standard classifications, and peak solder temperature.

Important Information and Disclaimer:The information provided on this page represents TI's knowledge and belief as of the date that it is provided. TI bases its knowledge and belief on information provided by third parties, and makes no representation or warranty as to the accuracy of such information. Efforts are underway to better integrate information from third parties. TI has taken and continues to take reasonable steps to provide representative and accurate information but may not have conducted destructive testing or chemical analysis on incoming materials and chemicals. TI and TI suppliers consider certain information to be proprietary, and thus CAS numbers and other limited information may not be available for release.

In no event shall TI's liability arising out of such information exceed the total purchase price of the TI part(s) at issue in this document sold by TI to Customer on an annual basis.

J (R-GDIP-T**)

14 LEADS SHOWN

CERAMIC DUAL IN-LINE PACKAGE

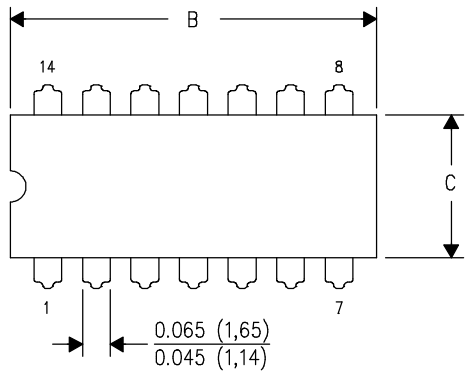

DIM \ PINS **	14	16	18	20
A	0.300 (7,62) BSC	0.300 (7,62) BSC	0.300 (7,62) BSC	0.300 (7,62) BSC
B MAX	0.785 (19,94)	.840 (21,34)	0.960 (24,38)	1.060 (26,92)
B MIN	—	—	—	—
C MAX	0.300 (7,62)	0.300 (7,62)	0.310 (7,87)	0.300 (7,62)
C MIN	0.245 (6,22)	0.245 (6,22)	0.220 (5,59)	0.245 (6,22)

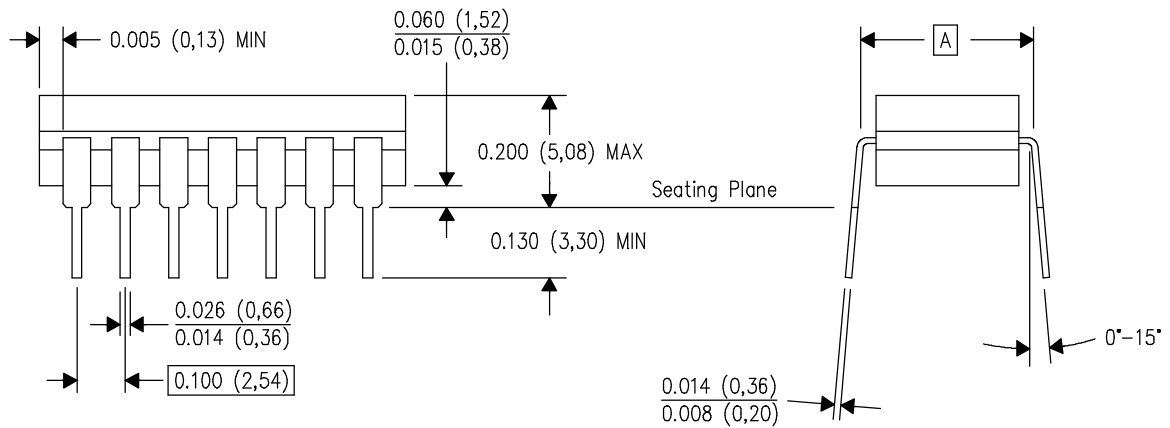

4040083/F 03/03

- NOTES:
- A. All linear dimensions are in inches (millimeters).
 - B. This drawing is subject to change without notice.
 - C. This package is hermetically sealed with a ceramic lid using glass frit.
 - D. Index point is provided on cap for terminal identification only on press ceramic glass frit seal only.
 - E. Falls within MIL STD 1835 GDIP1-T14, GDIP1-T16, GDIP1-T18 and GDIP1-T20.

MECHANICAL DATA

W (R-GDFP-F14)

CERAMIC DUAL FLATPACK

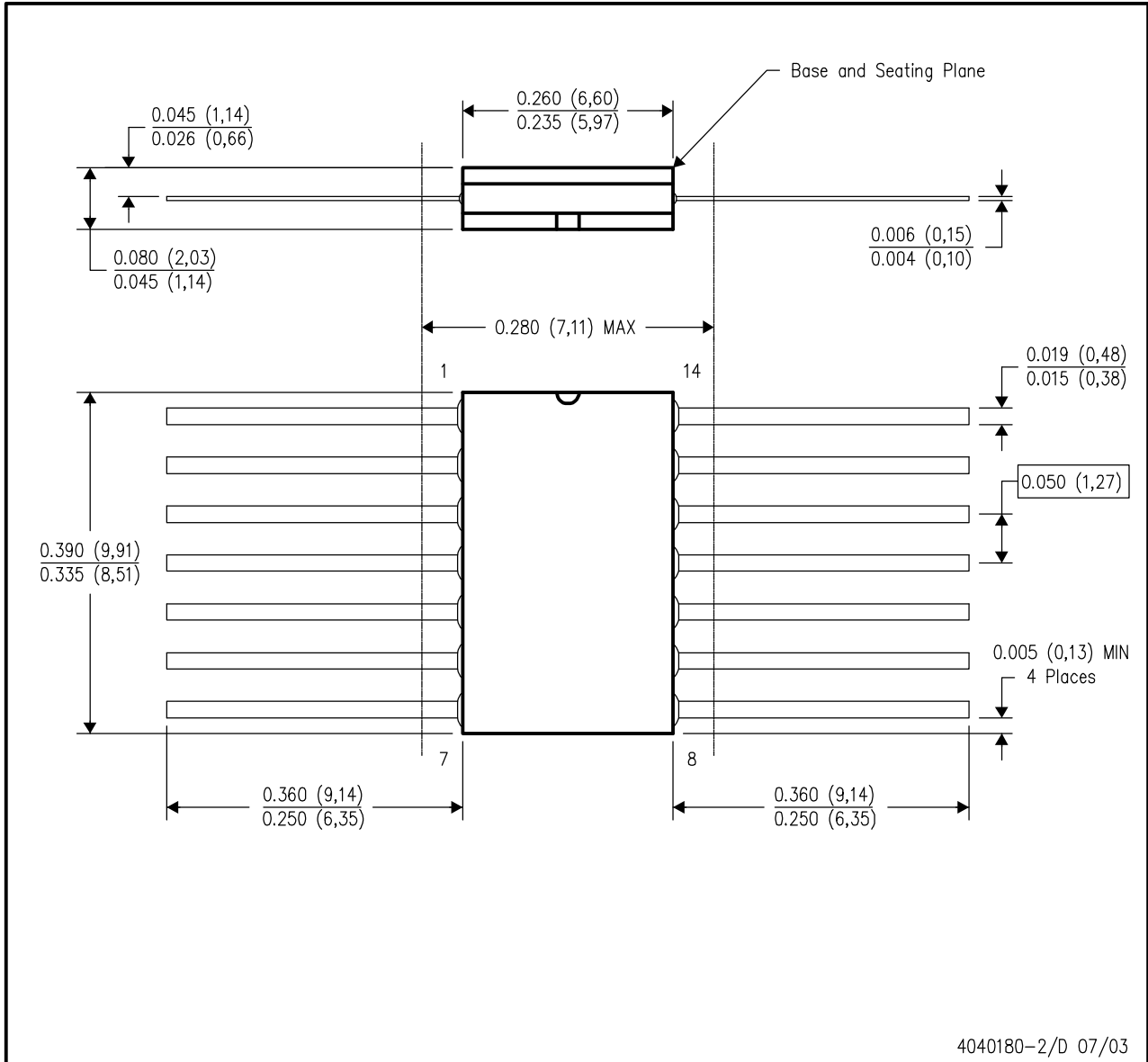

- NOTES:
- A. All linear dimensions are in inches (millimeters).
 - B. This drawing is subject to change without notice.
 - C. This package can be hermetically sealed with a ceramic lid using glass frit.
 - D. Index point is provided on cap for terminal identification only.
 - E. Falls within MIL STD 1835 GDFP1-F14 and JEDEC MO-092AB

MECHANICAL DATA

MLCC006B – OCTOBER 1996

FK (S-CQCC-N**)

LEADLESS CERAMIC CHIP CARRIER

28 TERMINAL SHOWN

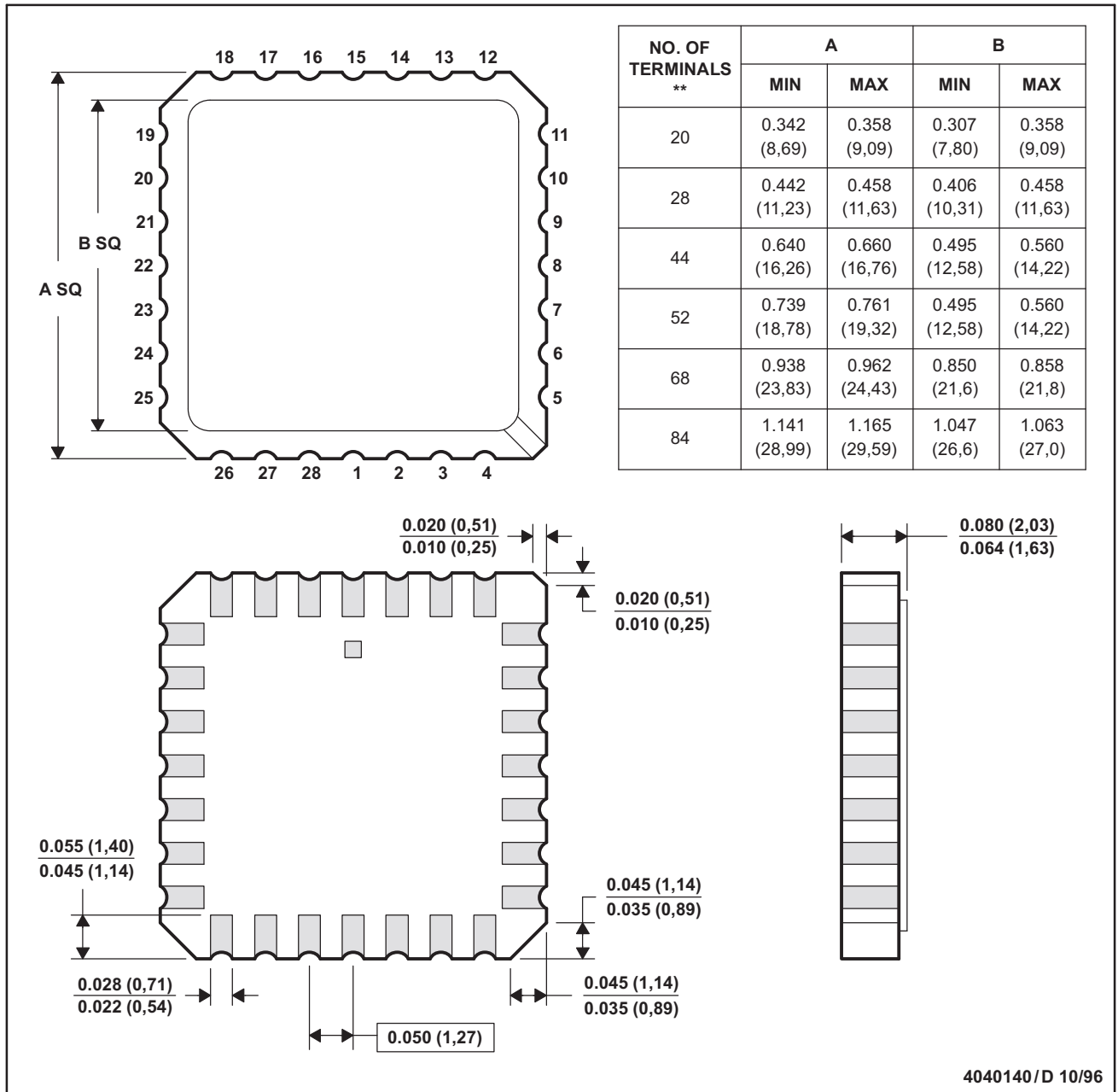

- NOTES:
- A. All linear dimensions are in inches (millimeters).
 - B. This drawing is subject to change without notice.
 - C. This package can be hermetically sealed with a metal lid.
 - D. The terminals are gold plated.
 - E. Falls within JEDEC MS-004

 **TEXAS
INSTRUMENTS**

POST OFFICE BOX 655303 • DALLAS, TEXAS 75265

MECHANICAL DATA

N (R-PDIP-T**)

16 PINS SHOWN

PLASTIC DUAL-IN-LINE PACKAGE

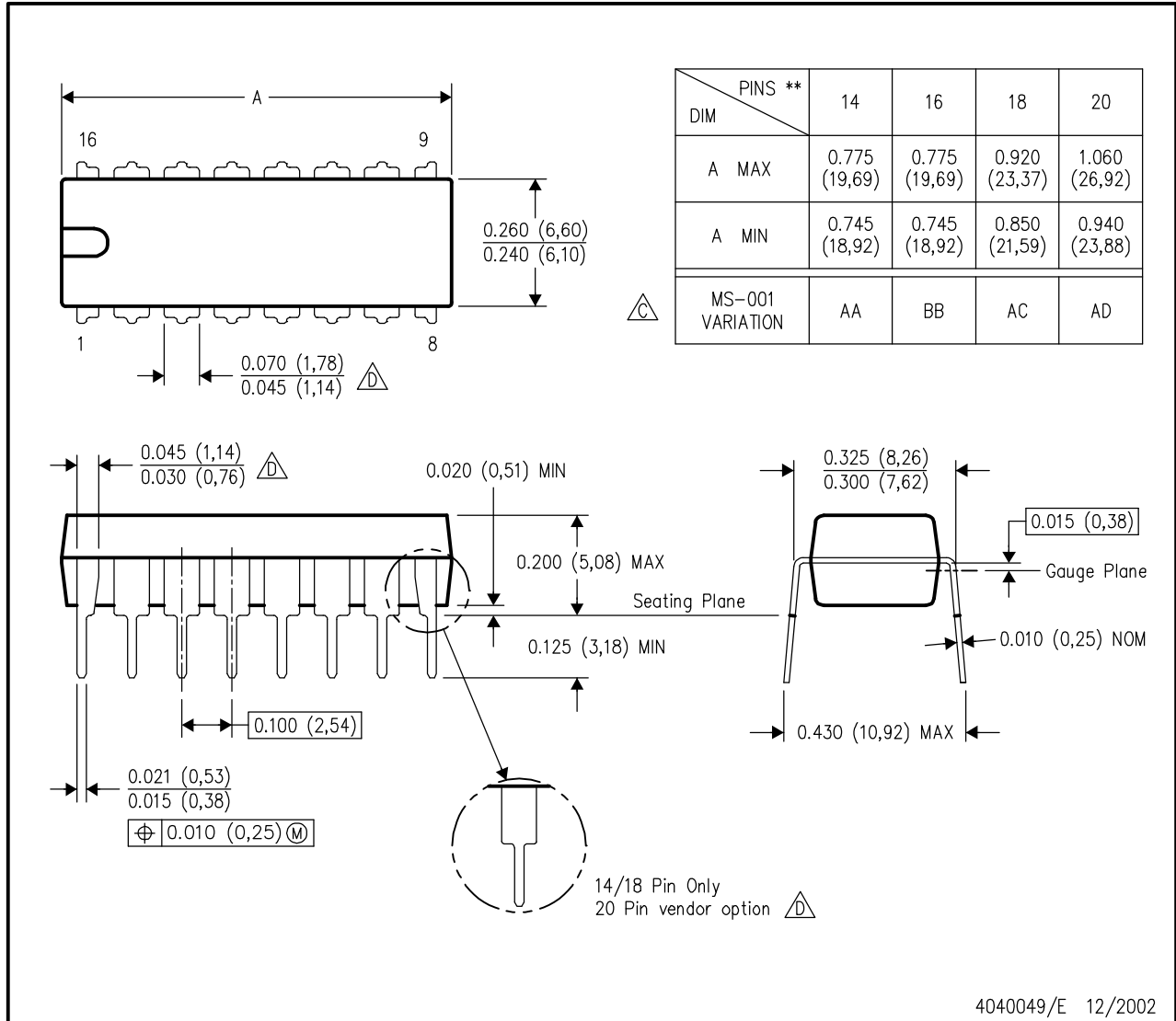

- NOTES:
- A. All linear dimensions are in inches (millimeters).
 - B. This drawing is subject to change without notice.
 - Falls within JEDEC MS-001, except 18 and 20 pin minimum body length (Dim A).
 - The 20 pin end lead shoulder width is a vendor option, either half or full width.

D (R-PDSO-G14)

PLASTIC SMALL-OUTLINE PACKAGE

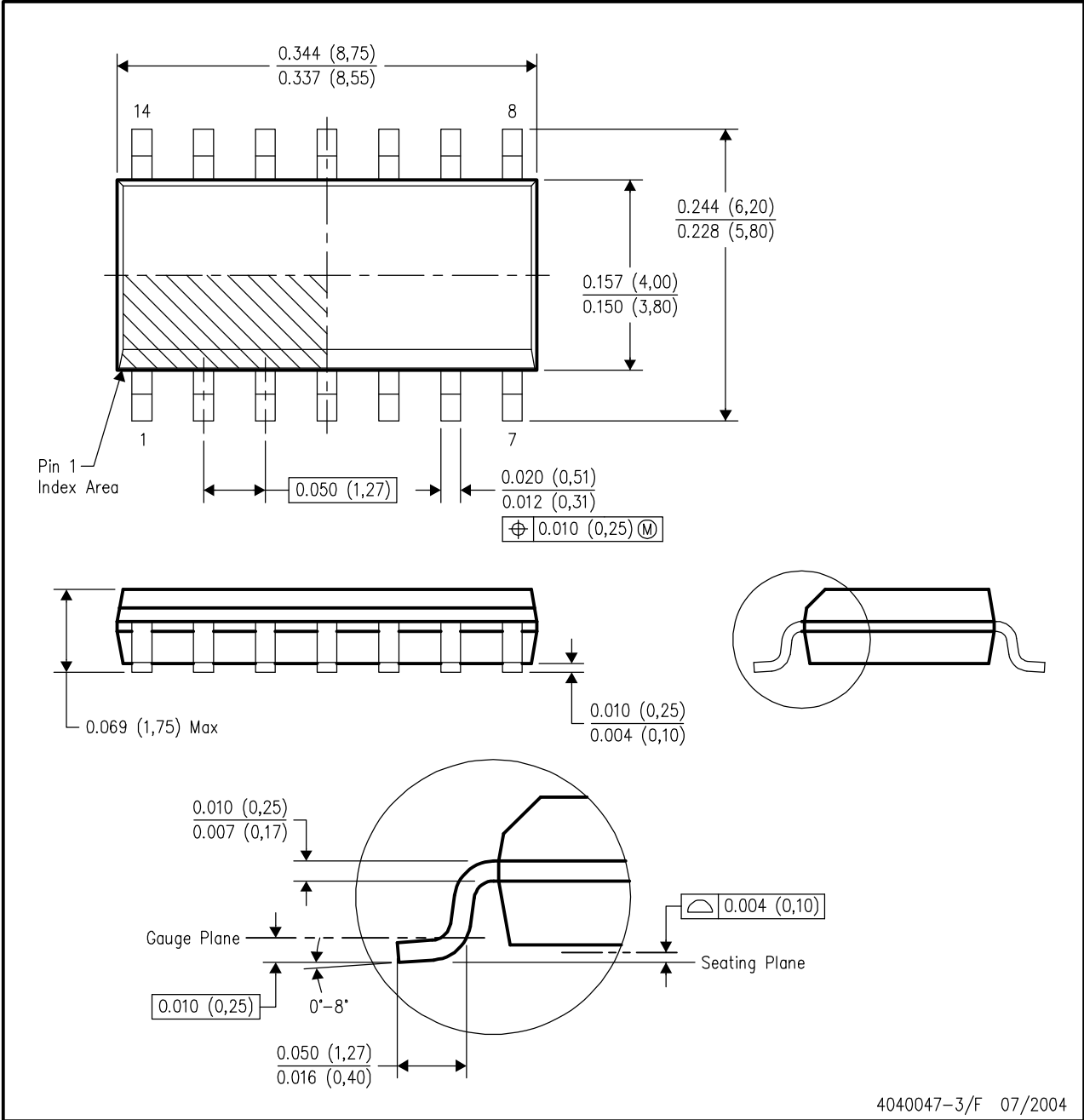

4040047-3/F 07/2004

- NOTES:
- A. All linear dimensions are in inches (millimeters).
 - B. This drawing is subject to change without notice.
 - C. Body dimensions do not include mold flash or protrusion not to exceed 0.006 (0,15).
 - D. Falls within JEDEC MS-012 variation AB.

MECHANICAL DATA

NS (R-PDSO-G)**

PLASTIC SMALL-OUTLINE PACKAGE

14-PINS SHOWN

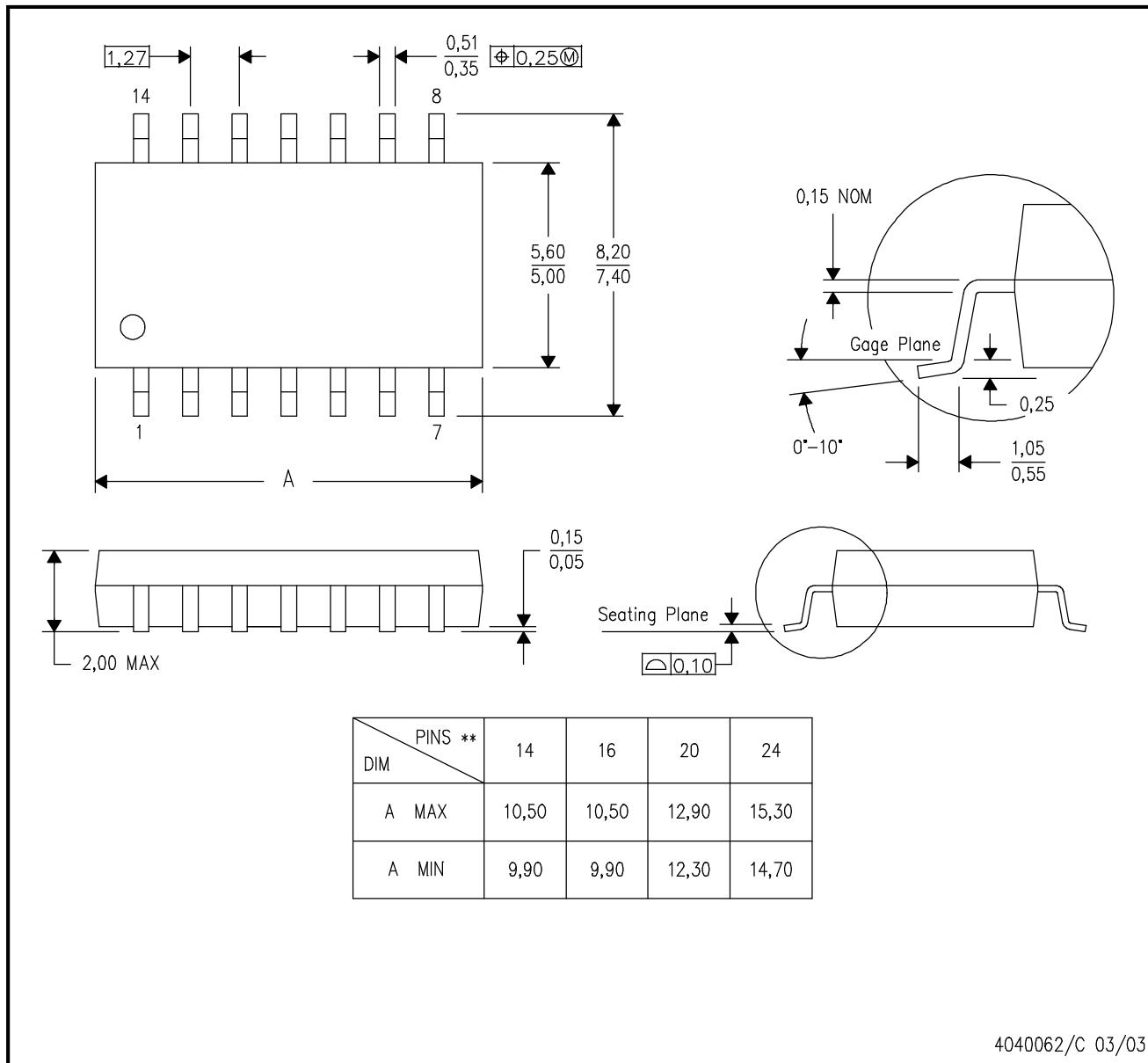

- NOTES:
- A. All linear dimensions are in millimeters.
 - B. This drawing is subject to change without notice.
 - C. Body dimensions do not include mold flash or protrusion, not to exceed 0,15.

MECHANICAL DATA

MSS0002E – JANUARY 1995 – REVISED DECEMBER 2001

DB (R-PDSO-G**)

PLASTIC SMALL-OUTLINE

28 PINS SHOWN

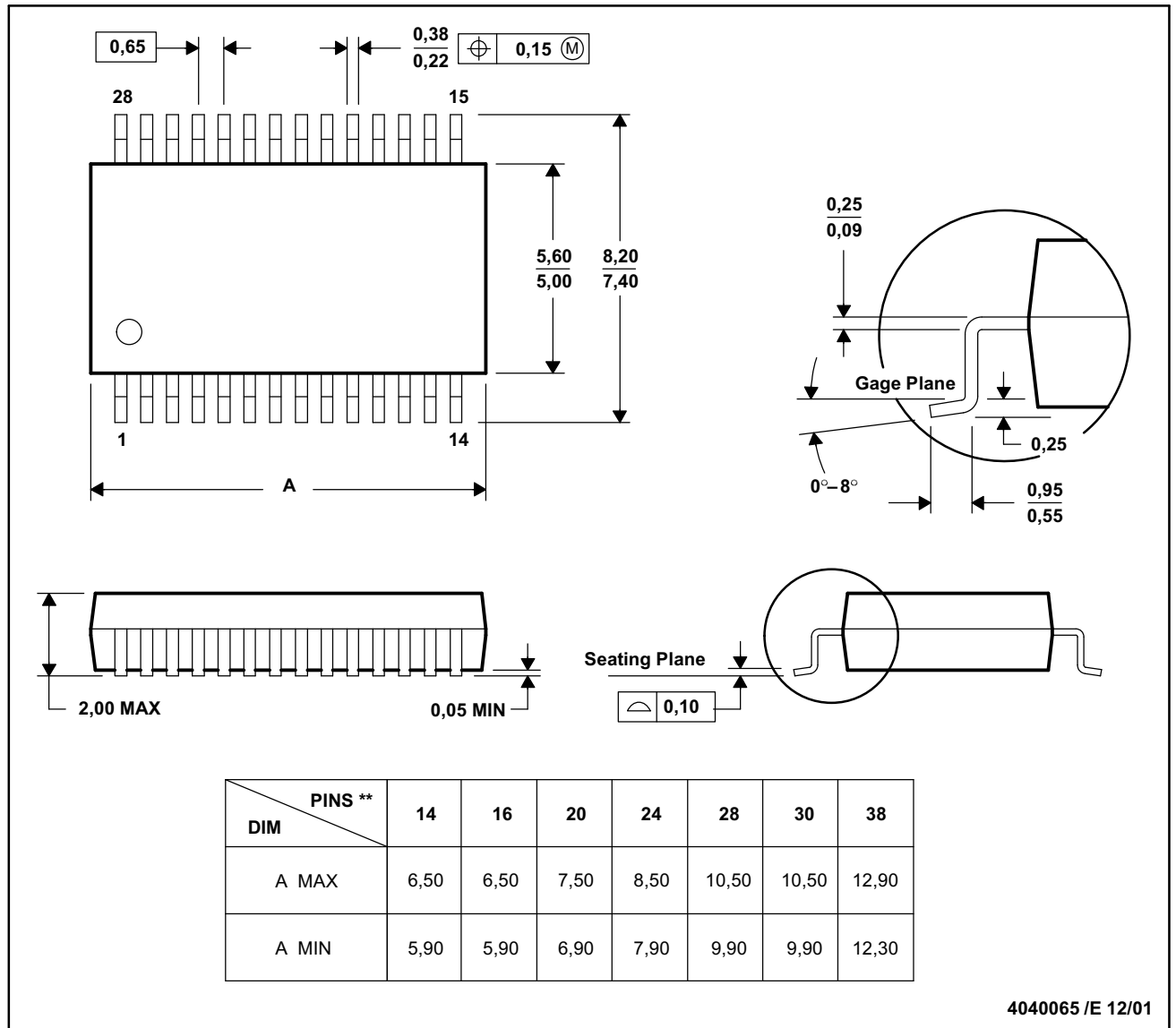

- NOTES: A. All linear dimensions are in millimeters.
 B. This drawing is subject to change without notice.
 C. Body dimensions do not include mold flash or protrusion not to exceed 0,15.
 D. Falls within JEDEC MO-150

IMPORTANT NOTICE

Texas Instruments Incorporated and its subsidiaries (TI) reserve the right to make corrections, modifications, enhancements, improvements, and other changes to its products and services at any time and to discontinue any product or service without notice. Customers should obtain the latest relevant information before placing orders and should verify that such information is current and complete. All products are sold subject to TI's terms and conditions of sale supplied at the time of order acknowledgment.

TI warrants performance of its hardware products to the specifications applicable at the time of sale in accordance with TI's standard warranty. Testing and other quality control techniques are used to the extent TI deems necessary to support this warranty. Except where mandated by government requirements, testing of all parameters of each product is not necessarily performed.

TI assumes no liability for applications assistance or customer product design. Customers are responsible for their products and applications using TI components. To minimize the risks associated with customer products and applications, customers should provide adequate design and operating safeguards.

TI does not warrant or represent that any license, either express or implied, is granted under any TI patent right, copyright, mask work right, or other TI intellectual property right relating to any combination, machine, or process in which TI products or services are used. Information published by TI regarding third-party products or services does not constitute a license from TI to use such products or services or a warranty or endorsement thereof. Use of such information may require a license from a third party under the patents or other intellectual property of the third party, or a license from TI under the patents or other intellectual property of TI.

Reproduction of information in TI data books or data sheets is permissible only if reproduction is without alteration and is accompanied by all associated warranties, conditions, limitations, and notices. Reproduction of this information with alteration is an unfair and deceptive business practice. TI is not responsible or liable for such altered documentation.

Resale of TI products or services with statements different from or beyond the parameters stated by TI for that product or service voids all express and any implied warranties for the associated TI product or service and is an unfair and deceptive business practice. TI is not responsible or liable for any such statements.

Following are URLs where you can obtain information on other Texas Instruments products and application solutions:

Products		Applications	
Amplifiers	amplifier.ti.com	Audio	www.ti.com/audio
Data Converters	dataconverter.ti.com	Automotive	www.ti.com/automotive
DSP	dsp.ti.com	Broadband	www.ti.com/broadband
Interface	interface.ti.com	Digital Control	www.ti.com/digitalcontrol
Logic	logic.ti.com	Military	www.ti.com/military
Power Mgmt	power.ti.com	Optical Networking	www.ti.com/opticalnetwork
Microcontrollers	microcontroller.ti.com	Security	www.ti.com/security
		Telephony	www.ti.com/telephony
		Video & Imaging	www.ti.com/video
		Wireless	www.ti.com/wireless

Mailing Address: Texas Instruments
Post Office Box 655303 Dallas, Texas 75265

Copyright © 2005, Texas Instruments Incorporated