

TOSHIBA PHOTOCOUPLER GaAlAs IRED & PHOTO IC

# 6N135, 6N136

- DIGITAL LOGIC ISOLATION.
- LINE RECEIVER.
- POWER SUPPLY CONTROL
- SWITCHING POWER SUPPLY
- TRANSISTOR INVERTER

The TOSHIBA 6N135 and 6N136 consists of a high emitting diode and a one chip photo diode-transistor.

Each unit is 8-lead DIP package.

- Isolation Voltage : 2500V<sub>rms</sub> (Min.)
- High Speed :  $t_{pHL}, t_{pLH} = 0.5\mu s$  (Typ.) ( $R_L = 1.9k\Omega$ )
- TTL Compatible
- If Base Pin is Open, Output Signal will be Noisy by Environmental Condition. For This Base, TLP550 is Suitable
- UL Recognized : UL1577, File No. E67349

Unit in mm

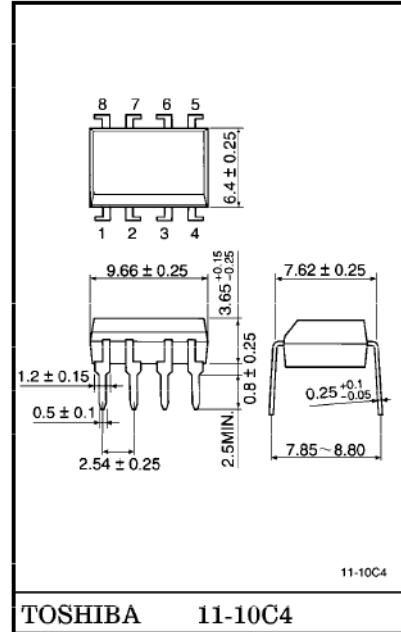

Weight : 0.54g

**PIN CONFIGURATIONS**

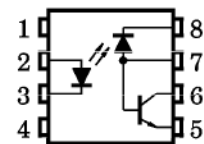

- 1 : N.C.
- 2 : ANODE
- 3 : CATHODE
- 4 : N.C.
- 5 : EMITTER
- 6 : COLLECTOR
- 7 : BASE, ANODE
- 8 : CATHODE

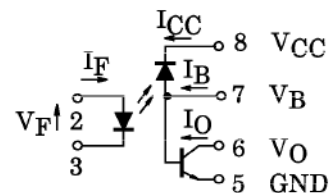

961001EBC2

● TOSHIBA is continually working to improve the quality and the reliability of its products. Nevertheless, semiconductor devices in general can malfunction or fail due to their inherent electrical sensitivity and vulnerability to physical stress. It is the responsibility of the buyer, when utilizing TOSHIBA products, to observe standards of safety, and to avoid situations in which a malfunction or failure of a TOSHIBA product could cause loss of human life, bodily injury or damage to property. In developing your designs, please ensure that TOSHIBA products are used within specified operating ranges as set forth in the most recent products specifications. Also, please keep in mind the precautions and conditions set forth in the TOSHIBA Semiconductor Reliability Handbook.

## MAXIMUM RATINGS (Ta = 25°C)

CHARACTERISTIC		SYMBOL	RATING	UNIT
LED	Forward Current (Note 1)	I <sub>F</sub>	25	mA
	Pulse Forward Current (Note 2)	I <sub>FP</sub>	50	mA
	Total Pulse Forward Current (Note 3)	I <sub>FPT</sub>	1	A
	Reverse Voltage	V <sub>R</sub>	5	V
	Diode Power Dissipation (Note 4)	P <sub>D</sub>	45	mW
DETECTOR	Output Current	I <sub>O</sub>	8	mA
	Peak Output Current	I <sub>OP</sub>	16	mA
	Emitter-Base Reverse Voltage (Pin 5-7)	V <sub>EB</sub>	5	V
	Supply Voltage	V <sub>CC</sub>	-0.5~15	V
	Output Voltage	V <sub>O</sub>	-0.5~15	V
	Base Current (Pin 7)	I <sub>B</sub>	5	mA
	Output Power Dissipation (Note 5)	P <sub>o</sub>	100	mW
Operating Temperature Range		T <sub>opr</sub>	-55~100	°C
Storage Temperature Range		T <sub>stg</sub>	-55~125	°C
Lead Solder Temperature (10s) (Note 6)		T <sub>sol</sub>	260	°C
Isolation Voltage (Note 7)		BV <sub>S</sub>	2500	V <sub>rms</sub>

(Note 1) Derate 0.8mA above 70°C.

(Note 2) 50% duty cycle, 1ms pulse width.  
Derate 1.6mA/°C above 70°C.

(Note 3) Pulse width 1μs, 300pps.

(Note 4) Derate 0.9mW/°C above 70°C.

(Note 5) Derate 2mW/°C above 70°C.

(Note 6) Soldering portion of lead : up to 2mm from the body of the device.

(Note 7) R.H. ≤ 60%, AC / 1min.

961001EBC2'

- Gallium arsenide (GaAs) is a substance used in the products described in this document. GaAs dust and fumes are toxic. Do not break, cut or pulverize the product, or use chemicals to dissolve them. When disposing of the products, follow the appropriate regulations. Do not dispose of the products with other industrial waste or with domestic garbage.
- The products described in this document are subject to foreign exchange and foreign trade control laws.
- The information contained herein is presented only as a guide for the applications of our products. No responsibility is assumed by TOSHIBA CORPORATION for any infringements of intellectual property or other rights of the third parties which may result from its use. No license is granted by implication or otherwise under any intellectual property or other rights of TOSHIBA CORPORATION or others.
- The information contained herein is subject to change without notice.

ELECTRICAL CHARACTERISTICS  
OVER RECOMMENDED TEMPERATURE ( $T_a = 0^\circ\text{C} \sim 70^\circ\text{C}$  unless otherwise noted)

CHARACTERISTIC		SYMBOL	TEST CONDITION	MIN.	(**)TYP.	MAX.	UNIT
Current Transfer Ratio	6N135	CTR	$I_F = 16\text{mA}$ , $V_O = 0.4\text{V}$ $V_{CC} = 4.5\text{V}$ , $T_a = 25^\circ\text{C}$ (Note 8)	7	18	—	%
	6N136			19	24	—	%
	6N135	CTR	$I_F = 16\text{mA}$ , $V_O = 0.5\text{V}$ $V_{CC} = 4.5\text{V}$ (Note 1)	5	13	—	%
	6N136			15	21	—	%
Logic Low Output Voltage	6N135	VOL	$I_F = 16\text{mA}$ , $I_O = 1.1\text{mA}$ $V_{CC} = 4.5\text{V}$	—	0.1	0.4	V
	6N136		$I_F = 16\text{mA}$ , $I_O = 2.4\text{mA}$ $V_{CC} = 4.5\text{V}$	—	0.1	0.4	V
Logic High Output Current		IOH	$I_F = 0\text{mA}$ , $V_O = V_{CC} = 5.5\text{V}$ $T_a = 25^\circ\text{C}$	—	3	500	nA
			$I_F = 0\text{mA}$ , $V_O = V_{CC} = 15\text{V}$ $T_a = 25^\circ\text{C}$	—	0.1	1	$\mu\text{A}$
		IOH	$I_F = 0\text{mA}$ , $V_O = V_{CC} = 15\text{V}$	—	—	50	$\mu\text{A}$
Logic Low Supply Current		ICCL	$I_F = 16\text{mA}$ , $V_O = \text{Open}$ $V_{CC} = 15\text{V}$	—	40	—	$\mu\text{A}$
Logic High Supply Current		ICCH	$I_F = 0\text{mA}$ , $V_O = \text{Open}$ $V_{CC} = 15\text{V}$ , $T_a = 25^\circ\text{C}$	—	0.01	1	$\mu\text{A}$
		ICCH	$I_F = 0\text{mA}$ , $V_O = \text{Open}$ $V_{CC} = 15\text{V}$	—	—	2	$\mu\text{A}$
Input Forward Voltage		$V_F$	$I_F = 16\text{mA}$ , $T_a = 25^\circ\text{C}$	—	1.65	1.7	V
Temperature Coefficient of Forward Voltage		$\Delta V_F / \Delta T_a$	$I_F = 16\text{mA}$	—	-1.9	—	$\text{mV}/^\circ\text{C}$
Input Reverse Breakdown Voltage		$BV_R$	$I_R = 10\mu\text{A}$ , $T_a = 25^\circ\text{C}$	5	—	—	V
Input Capacitance		$C_{IN}$	$f = 1\text{MHz}$ , $V_F = 0$	—	60	—	pF
Resistance (Input-Output)		$R_{I-O}$	$V_{I-O} = 500\text{V}$ (Note 9) $R.H. \leq 60\%$	—	$10^{12}$	—	$\Omega$
Capacitance (Input-Output)		$C_{I-O}$	$f = 1\text{MHz}$ (Note 9)	—	0.6	—	pF
Transistor DC Current Gain		$h_{FE}$	$V_O = 5\text{V}$ , $I_O = 3\text{mA}$	—	80	—	—

(\*\*) All typicals at  $T_a = 25^\circ\text{C}$

## SWITCHING SPECIFICATIONS

(Unless otherwise specified.  $T_a = 25^\circ\text{C}$ ,  $V_{CC} = 5\text{V}$ ,  $I_F = 16\text{mA}$ )

CHARACTERISTIC		SYMBOL	TEST CIRCUIT	TEST CONDITION	MIN.	TYP.	MAX.	UNIT
Propagation Delay Time to Logic Low at Output	6N135	$t_{pHL}$	1	$R_L = 4.1\text{k}\Omega$	—	0.2	1.5	$\mu\text{s}$
	6N136			$R_L = 1.9\text{k}\Omega$	—	0.2	0.8	$\mu\text{s}$
Propagation Delay Time to Logic High at Output	6N135	$t_{pLH}$	1	$R_L = 4.1\text{k}\Omega$	—	1.0	1.5	$\mu\text{s}$
	6N136			$R_L = 1.9\text{k}\Omega$	—	0.5	0.8	$\mu\text{s}$
Common Mode Transient Immunity at Logic High Level Output (Note 10)	6N135	$CM_H$	2	$I_F = 0\text{mA}$ $V_{CM} = 10V_{p-p}$ $R_L = 4.1\text{k}\Omega$	—	1000	—	$V / \mu\text{s}$
	6N136			$I_F = 0\text{mA}$ $V_{CM} = 10V_{p-p}$ $R_L = 1.9\text{k}\Omega$	—	1000	—	$V / \mu\text{s}$
Common Mode Transient Immunity at Logic Low Level Output (Note 10)	6N135	$CM_L$	2	$V_{CM} = 10V_{p-p}$ $R_L = 4.1\text{k}\Omega$ $I_F = 16\text{mA}$	—	-1000	—	$V / \mu\text{s}$
	6N136			$V_{CM} = 10V_{p-p}$ $R_L = 1.9\text{k}\Omega$ $I_F = 16\text{mA}$	—	-1000	—	$V / \mu\text{s}$
Bandwidth (Note 11)		BW	—	$R_L = 100\Omega$	—	2	—	MHz

(Note 8) DC CURRENT TRANSFER RATIO is defined as the ratio of output collector current,  $I_O$ , to the forward LED input current,  $I_F$ , times 100%.

(Note 9) Device considered a two-terminal device : Pins 1, 2, 3, and 4 shorted together and Pins 5, 6, 7 and 8 shorted together.

(Note 10) Common mode transient immunity in Logic High level is the maximum tolerable (positive)  $dv_{CM}/dt$  on the leading edge of the common mode pulse,  $V_{CM}$ , to assure that the output will remain in a Logic High state (i.e.,  $V_O > 2.0\text{V}$ ).  
Common mode transient immunity in Logic Low level is the maximum tolerable (negative)  $dv_{CM}/dt$  on the trailing edge of the common mode pulse signal,  $V_{CM}$ , to assure that the output will remain in a Logic Low state (i.e.,  $V_O < 0.8\text{V}$ ).

(Note 11) The frequency at which the AC output voltage is 3dB below the low frequency asymptote.

TEST CIRCUIT 1.

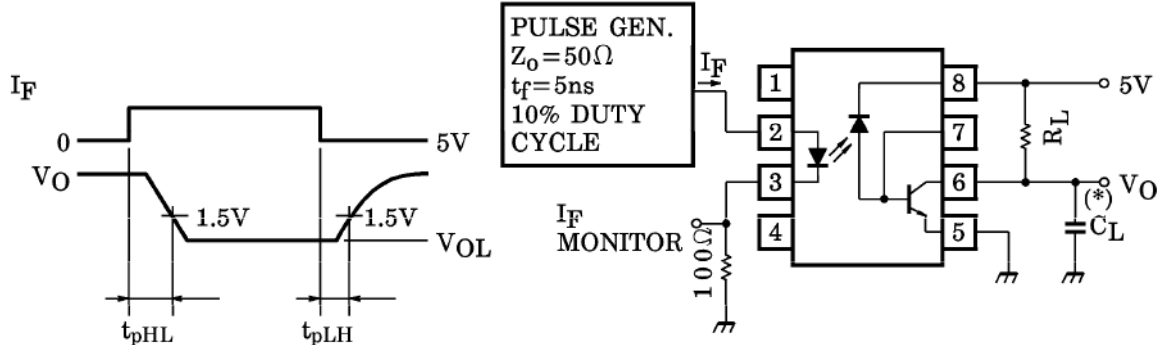

(\*)  $C_L$  is approximately 15pF which includes probe and stray wiring capacitance.

TEST CIRCUIT 2.

