

Tous droits strictement reserves. Reproduction ou communication a des tiers interdite sous quelque forme que ce soit sans autorisation ecrite du proprietaire. Propriete de c FCI. Droits de reproduction FCI.

**A**  
**FCI**

All rights strictly reserved. Reproduction or issue to third parties in any form whatever is not permitted without written authority from the proprietor. Property of FCI. Copyright FCI.

**B**

PRODUCT NUMBER  
SEE TABLE

1 | 2

3

4

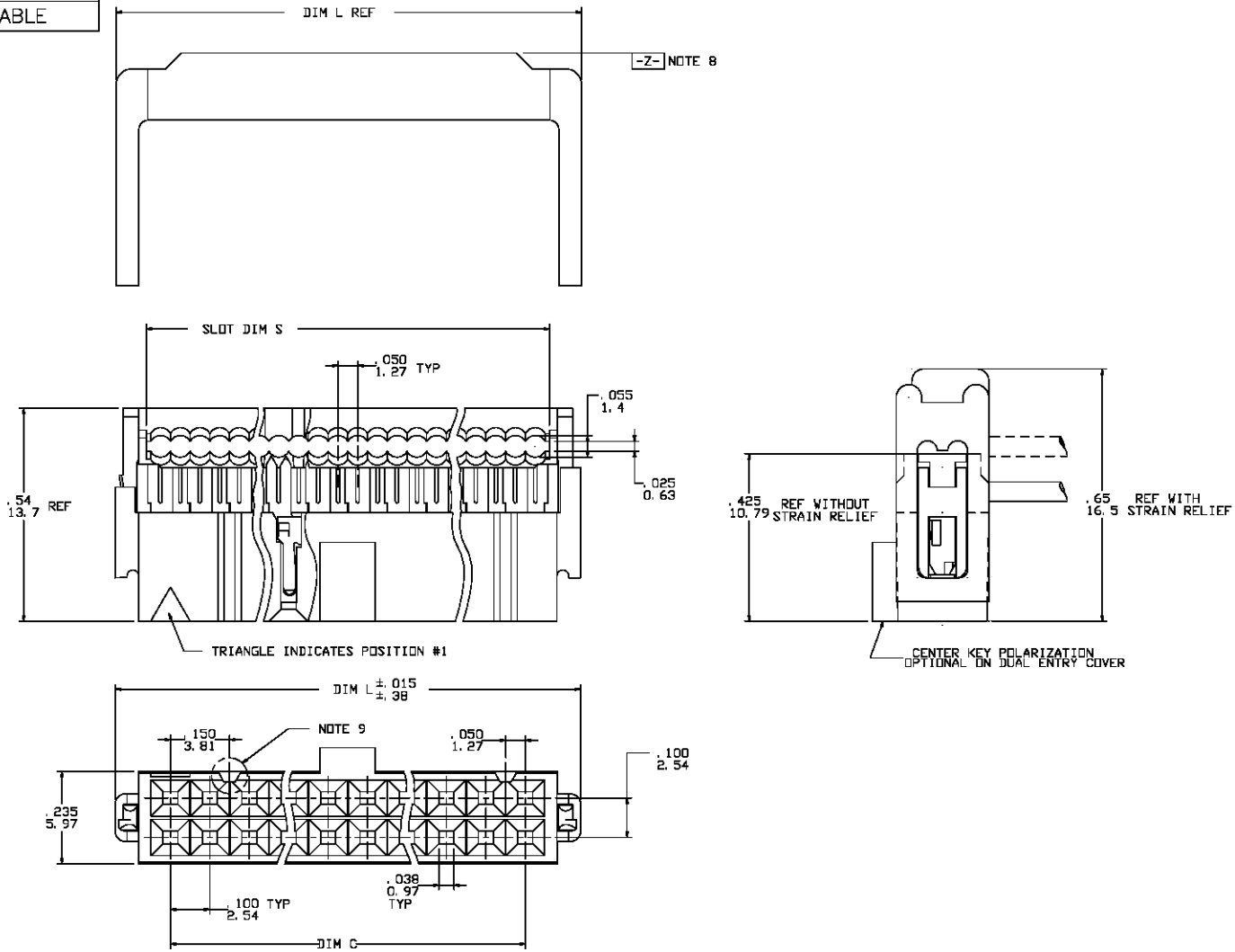

mat'l. code				tolerances unless otherwise specified				CUSTOMER COPY		 www.fciconnect.com	
ltr	ecn no	dr	date	linear	.XX ±.01/.X±.3			projection	title		
N	REDRAW	MRC	1/3/91		.XXX ±.005/.XX±.13				DUAL POLARIZED QUICKIE II ASSEMBLY		
P	V13269	JM	12/12/91	angles	.XXXX ±.0020/.XXX±.051			 INCH/MM	product family QUICKIE		code
R	V22169	MSC	5/21/92		0° ±2°				size   dwg no		sheet
S	N05-0060	MHT	7/25/05	dr	M. CORNMAN	1/3/91	scale	A	66900	1 of 2	
				enr	M. SMYK	1/3/91					
				chr	M. SMYK	1/3/91					
				appd	M. SMYK	1/3/91	8:1				
sheet index	revision sheet	S	S								
		1	2								

1 | 2

3

4

ACAD

PDM: Rev:S

STATUS: Released

cage code  
22526

Printed: Feb 19, 2008

PRODUCT No. NOTE 12	SIZE	DIM L	DIM S	DIM C
66900-X10	2X5	.680/17.27	.520/13.21	.400/10.16
-X14	2X7	.880/22.35	.720/18.29	.600/15.24
-X16	2X8	.980/24.89	.820/20.83	.700/17.78
-X20	2X10	1.180/29.97	1.020/25.91	.900/22.86
-X24	2X12	1.380/35.05	1.220/30.99	1.100/27.94
-X26	2X13	1.480/37.59	1.320/33.53	1.200/30.48
-X30	2X15	1.680/42.67	1.520/38.61	1.400/35.56
-X34	2X17	1.880/47.75	1.720/43.69	1.600/40.64
-X40	2X20	2.180/55.37	2.020/51.31	1.900/48.26
-X44	2X22	2.380/60.45	2.220/56.39	2.100/53.34
-X50	2X25	2.680/68.07	2.520/64.01	2.400/60.96
66900-X60	2X30	3.180/80.77	3.020/76.71	2.900/73.66

DASH NO	COVER		POLARIZATION	STRAIN RELIEF
	STYLE	ORIENTATION		
-0XX	THRU	DUAL ENTRY	DUAL POL.	YES
-1XX	THRU	DUAL ENTRY	DUAL POL.	NO
-2XX	THRU	DUAL ENTRY	CENTER KEY & DUAL POL.	YES
-3XX	THRU	DUAL ENTRY	CENTER KEY & DUAL POL.	NO
-4XX	BLIND	RIGHT	DUAL POL.	YES
-5XX	BLIND	RIGHT	DUAL POL.	NO
-6XX	BLIND	LEFT	DUAL POL.	YES
-7XX	BLIND	LEFT	DUAL POL.	NO
-8XX	BLIND	RIGHT	CENTER KEY & DUAL POL.	YES
-9XX	BLIND	LEFT	CENTER KEY & DUAL POL.	YES

COVER ORIENTATION

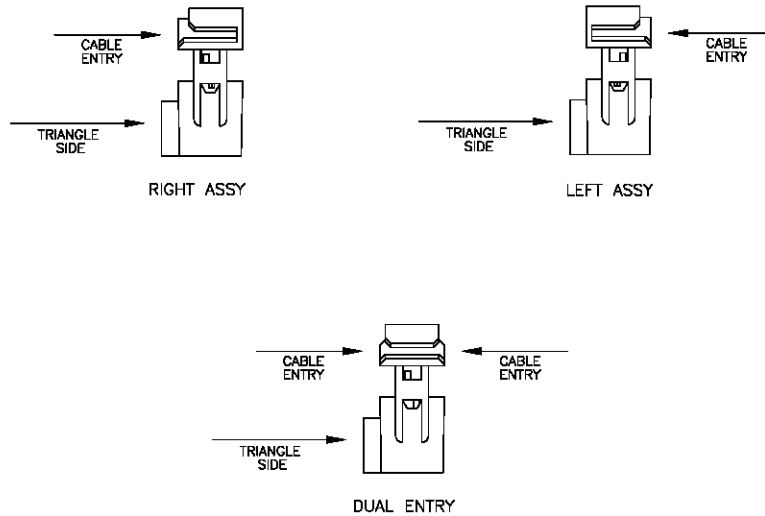

NOTES:

1. TERMINAL MATERIAL: FULL HARD PHOS. BRONZE ALLOY, UNS-C51000.
2. TERMINAL PLATING: 50u"/27u MIN NI UNDERPLATE OVER ENTIRE TERMINAL AND 30u"/.76u MIN Au IN DISCONNECT AREA ONLY.
3. MOLDING MATERIAL: BASE & COVER- GLASS FILLED POLYESTER, FLAME RETARDANT PER UL94V-0, COLOR- BLUE.
4. CONNECTOR ASSEMBLIES PACKAGED IN TUBES.
5. THE FIRST TWO CAVITY POSITIONS AND THE LAST TWO, ARE IDENTIFIED BY NUMBER.
6. POLARIZING FEATURES ARE DESCRIBED IN TABLE.
7. MOLDING MATERIAL: STRAIN RELIEF- NYLON, FLAME RETARDANT PER UL94V-0, COLOR- BLUE.
8. STRAIN RELIEF DIM APPLIES WHEN DATUM -Z- IS HELD IN A RESTRAINED CONDITION.
9. THE POLARIZING FEATURE ON THIS END IS NON-EXISTANT ON 2?5 AND 2?7 POSITION CONNECTORS.
10. 2x5 POSITION NOT AVAILABLE WITH POLARIZATION SLOT ON CENTER KEY STYLE.
11. TO ORDER PARTS THAT DO NOT HAVE "MARKED INFO", (DATE, P/N, ETC), ADD A "U" AFTER THE PART NUMBER. EXAMPLE 66900-010 U.
12. ADD "LF" SUFFIX AT THE END OF PART NUMBER FOR LEAD FREE OPTION.
13. IF "LF" P/N THE PRODUCT MEETS EUROPEAN UNION DIRECTIVES AND OTHER COUNTRY REGULATION AS DESCRIBED IN GS-22-008.
14. THE PRODUCT IS NOT INTENDED TO BE EXPOSED TO A MANUFACTURING SOLDER PROCESS.

mat'l. code				tolerances unless otherwise specified		CUSTOMER COPY		 www.fciconnect.com			
ltr	ecn no	dr	date	linear	.xx ±.01/.x±.3	projection		title			
S					.xxx ±.005/.xx±.13			DUAL POLARIZED			
					.xxx ±.0020/.xxx±.051			QUICKIE II ASSEMBLY			
				angles	0° ±2°	 INCH/MM	product family size dwg no	code			
				dr	M. CORNMAN 1/3/91			QUICKIE			
				enrg	M. SMYK 1/3/91			66900		sheet	
				chr	M. SMYK 1/3/91	scale	A	2 of			
				appd	M. SMYK 1/3/91			8:1			
sheet index	revision sheet										