

PRODUCT NO.  
SEE SHT. 2

SIDE VIEW OF ASS'Y.  
AFTER TERMINATION

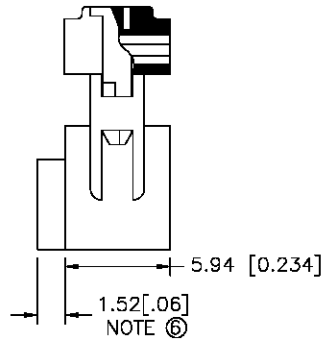
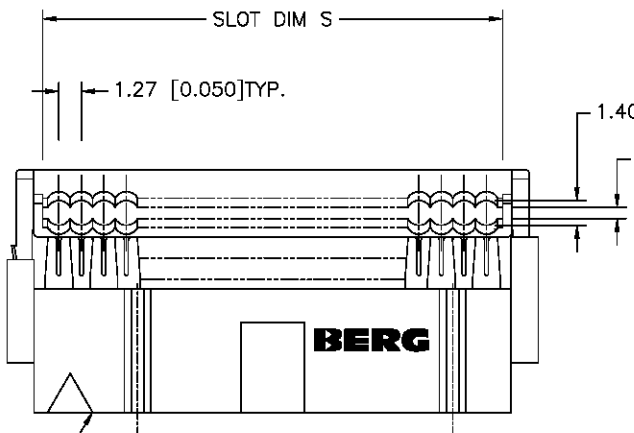
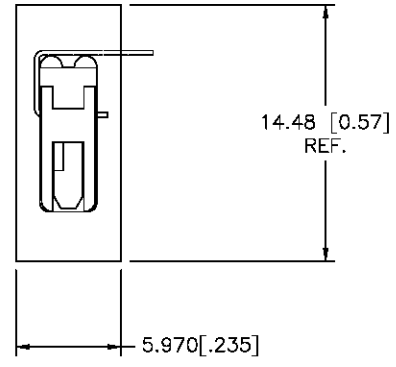
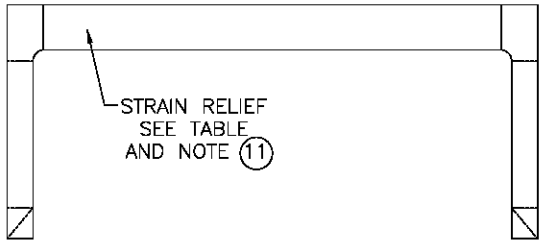

13.72 [0.54] REF.

TRIANGLE INDICATES  
POSITION ONE

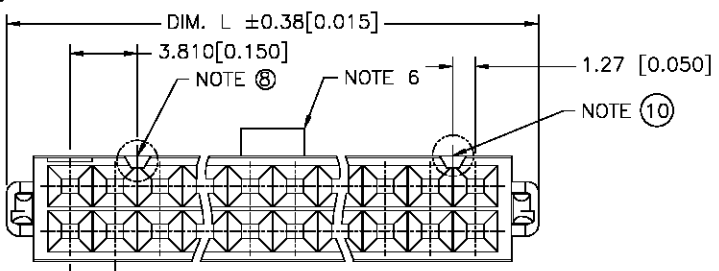

Tous droits strictement reserves. Reproduction ou communication a des tiers  
 interdite sous quelque forme que ce soit sans autorisation ecrite du proprietaire.  
 Propriete de c FCI. Droits de reproduction FCI.

All rights strictly reserved. Reproduction or issue to third parties in any  
 form whatever is not permitted without written authority from the proprietor.  
 Property of FCI. Copyright FCI.

mat'l. code				tolerances unless otherwise specified		CUSTOMER COPY	 www.fciconnect.com
ltr	ecn no	dr	date	linear	.XX ±.01/.X±.3		
E	TRANSFER	RHA	11/23/81		.XXX ±.005/.XX±.13	 MM/INCH	product family QUICKIE
F	RELEASED	BLI	1/82	angles	.XXX ±.0020/.XXX±.051		
G	5003	BLI	8/83		0° ±2°	size A	sheet 1 of 2
H	N10816	CN	10/88	dr	R.G. Draggoo 10/2/98		
J	V81770	RGD	10/2/98	engr	M. SYMK 10/2/98	size A	
K	V90596	RGD	3/2/99	chr	M. SYMK 10/2/98	size A	
L	N05-0060	MHT	03/04/05	appd	M. SYMK 10/2/98	size A	
sheet index	revision sheet	L	L				
		1	2				

Tous droits strictement reserves. Reproduction ou communication a des tiers interdite sous quelque forme que ce soit sans autorisation ecrite du proprietaire. Propriete de c FCI. Droits de reproduction FCI.

**A** FCI

All rights strictly reserved. Reproduction or issue to third parties in any form whatever is not permitted without written authority from the proprietor. Property of FCI. Copyright FCI.

**B**

PRODUCT NO.	SIZE	DIM "L"	DIM "S"	LEAD FREE OPTION
66564-X06	2x3	12.19/[.480]	8.128/[.320]	NOTE 13, 14
66564-X08	2x4	14.73/[.580]	10.668/[.420]	
66564-X10	2x5	17.27/[.680]	13.210/[.520]	
-X14	2x7	22.35/[.880]	18.290/[.720]	
-X16	2x8	24.89/[.980]	20.830/[.820]	
-X20	2x10	29.97/[1.180]	25.910/[1.020]	
-X26	2x13	37.59/[1.480]	33.530/[1.320]	
-X34	2x17	47.75/[1.880]	43.690/[1.720]	
-X40	2x20	55.37/[2.180]	51.310/[2.020]	
-X50	2x25	68.07/[2.680]	64.010/[2.520]	
66564-X60	2x30	80.77/[3.180]	76.710/[3.020]	

X	COVER		POL. KEY	STR REL.	
	STYLE	ENTRY			
5	THRU	DUAL	NO	NO	SEE NOTE 12
6	THRU	DUAL	NO	NO	SEE NOTE 11
7	THRU	DUAL	YES	NO	SEE NOTE 11
8	THRU	DUAL	YES	YES	
9	THRU	DUAL	NO	YES	

**NOTES:**

1. TERMINAL MAT'L: PHOS BRONZE, FULL HARD, ALLOY UNS-C51000.
2. TERMINAL PLATING: 0.7u/30u" GOLD IN CONTACT AREA OVER 1.27u 50u" NICKEL. REMAINDER OF TERM. 1.27u 50u" NICKEL.
3. MOLDING MAT'L: BASE AND COVER- GLASS FILLED POLYESTER, FLAME RETARDANT PER UL 94V-0: COLOR- BLUE
4. CONNECTOR ASS'YS PACKAGED IN TUBES THEN BOXED IN LOTS OF 100.
5. THE FIRST TWO CAVITY POSITIONS AND THE LAST TWO ARE IDENTIFIED BY NUMBER
6. POLARIZING FEATURE OPTIONAL, SEE TABLE.
7. MOLDING MAT'L: STRAIN RELIEF- UNFILLED THERMOPLASTIC, FLAME-RETARDANT: UL 94 V-0: COLOR-BLUE.
8. THE POLARIZING FEATURE ON THIS END IS NON EXISTENT ON 6,8,10, AND 14 POS. CONNECTORS.
9. 10 POSITION CONNECTOR NOT AVAILABLE WITH BOTH POL. SLOTS AND KEY.
10. THE POLARIZING FEATURE ON THIS END IS NON EXISTENT ON 6 AND 8 POS. CONNECTORS.
11. THE PRODUCT NUMBERS 66564-6XX AND 66564-7XX ONLY COUNT FOR 2x3 AND 2x4 POS. CONNECTORS FOR ALL OTHER VERSIONS WITHOUT STRAIN RELIEF (2x5---2x30) REFER TO P/N 66900
12. PRODUCT NUMBER 66564-506 ONLY WITHOUT BERG LOGO.
13. ADD "LF" SUFFIX AT THE END OF PART NUMBER FOR LEAD FREE OPTION.
14. THESE PRODUCTS MEET EUROPEAN UNION DIRECTIVES AND OTHER COUNTRY REGULATION AS DESCRIBED IN GS-22-008.
15. THE PRODUCT IS NOT INTENDED TO BE EXPOSED TO A MANUFACTURING SOLDER PROCESS.

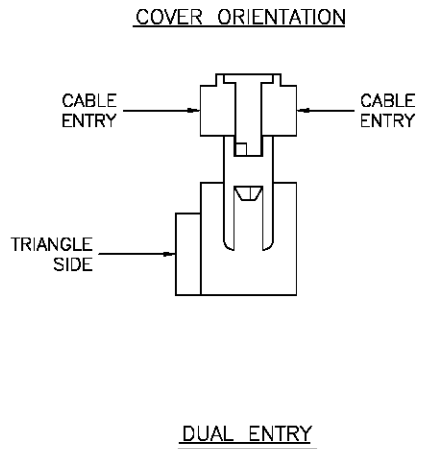

mat'l. code				tolerances unless otherwise specified		CUSTOMER COPY		 www.fciconnect.com			
ltr	ecn no	dr	date	linear	.xx ±.01/.x±.3	projection		title			
L					.xxx ±.005/.xx±.13			QUICKIE L.P. ASS'Y		code	
					.xxx ±.0020/.xxx±.051			STRAIN RELIEF		-	
				angles	0° ±2°		MM/INCH	product family			
				dr	R.G Dragoo 10/2/98			QUICKIE		sheet	
				enr	M. SYMK 10/2/98			size		2 of	
				chr	M. SYMK 10/2/98			A		66564	
				appd	M. SYMK 10/2/98	scale	1:1				
sheet index	revision sheet										