

54F/74F823 9-Bit D-Type Flip-Flop

General Description

The 'F823 is a 9-bit buffered register. It features Clock Enable and Clear which are ideal for parity bus interfacing in high performance microprogramming systems.

The 'F823 is functionally and pin compatible with AMD's Am29823.

Features

- TRI-STATE® outputs
- Clock Enable and Clear
- Direct replacement for AMD's Am29823

Commercial	Military	Package Number	Package Description
74F823SPC		N24C	24-Lead (0.300" Wide) Molded Dual-In-Line
	54F823SDM (Note 2)	J24F	24-Lead (0.300" Wide) Ceramic Dual-In-Line
74F823SC (Note 1)		M24B	24-Lead (0.300" Wide) Molded Small Outline, JEDEC
	54F823FM (Note 2)	W24C	24-Lead Cerpack
	54F823LM (Note 2)	E28A	24-Lead Ceramic Chip Carrier, Type C

Note 1: Devices also available in 13" reel. Use suffix = SCX.

Note 2: Military grade device with environmental and burn-in processing. Use suffix = SDMQB, FMQB and LMQB.

Logic Symbols

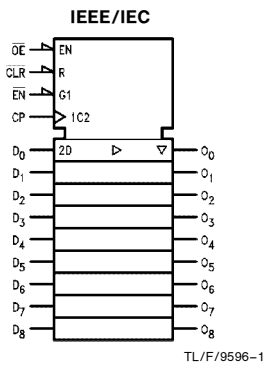
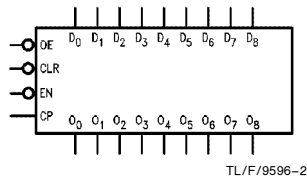

Connection Diagrams

Pin Assignment for DIP, SOIC and Flatpak

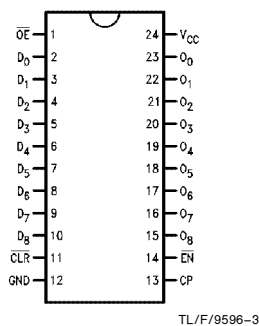

Pin Assignment for LCC

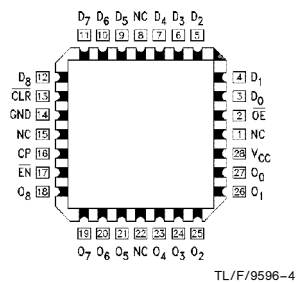

TRI-STATE® is a registered trademark of National Semiconductor Corporation.

Unit Loading/Fan Out

Pin Names	Description	54F/74F	
		U.L. HIGH/LOW	Input I_{IH}/I_{IL} Output I_{OH}/I_{OL}
D_0-D_8	Data Inputs	1.0/1.0	20 μA / -0.6 mA
\overline{OE}	Output Enable Input	1.0/1.0	20 μA / -0.6 mA
\overline{CLR}	Clear	1.0/1.0	20 μA / -0.6 mA
CP	Clock Input	1.0/2.0	20 μA / -1.2 mA
\overline{EN}	Clock Enable	1.0/1.0	20 μA / -0.6 mA
O_0-O_8	TRI-STATE Outputs	150/40 (33.3)	-3 mA/24 mA (20 mA)

Functional Description

The 'F823 device consists of nine D-type edge-triggered flip-flops. It has TRI-STATE true outputs and is organized in broadside pinning. The buffered Clock (CP) and buffered Output Enable (\overline{OE}) are common to all flip-flops. The flip-flops will store the state of their individual D inputs that meet the setup and hold times requirements on the LOW-to-HIGH CP transition. With the \overline{OE} LOW the contents of the flip-flops are available at the outputs. When the \overline{OE} is HIGH, the outputs go to the high impedance state. Operation of the \overline{OE} input does not affect the state of the flip-flops. In addition to the Clock and Output Enable pins, the 'F823 has Clear (\overline{CLR}) and Clock Enable (\overline{EN}) pins.

When the \overline{CLR} is LOW and the \overline{OE} is LOW, the outputs are LOW. When \overline{CLR} is HIGH, data can be entered into the flip-flops. When \overline{EN} is LOW, data on the inputs is transferred to the outputs on the LOW to HIGH clock transition. When the \overline{EN} is HIGH, the outputs do not change state regardless of the data or clock inputs transitions. This device is ideal for parity bus interfacing in high performance systems.

Function Table

Inputs					Internal	Output	Function
\overline{OE}	\overline{CLR}	\overline{EN}	CP	D	\overline{Q}	O	
H	H	L	H	X	NC	Z	Hold
H	H	L	L	X	NC	Z	Hold
H	H	H	X	X	NC	Z	Hold
L	H	H	X	X	NC	NC	Hold
H	L	X	X	X	H	Z	Clear
L	L	X	X	X	H	L	Clear
H	H	L	/	H	H	Z	Load
H	H	L	/	H	L	Z	Load
L	H	L	/	L	H	L	Data Available
L	H	L	/	H	L	H	Data Available
L	H	L	H	X	NC	NC	No Change in Data
L	H	L	L	X	NC	NC	No Change in Data

L = LOW Voltage Level
H = HIGH Voltage Level
X = Immaterial
Z = High Impedance
/ = LOW-to-HIGH Transition
NC = No Change

Logic Diagram

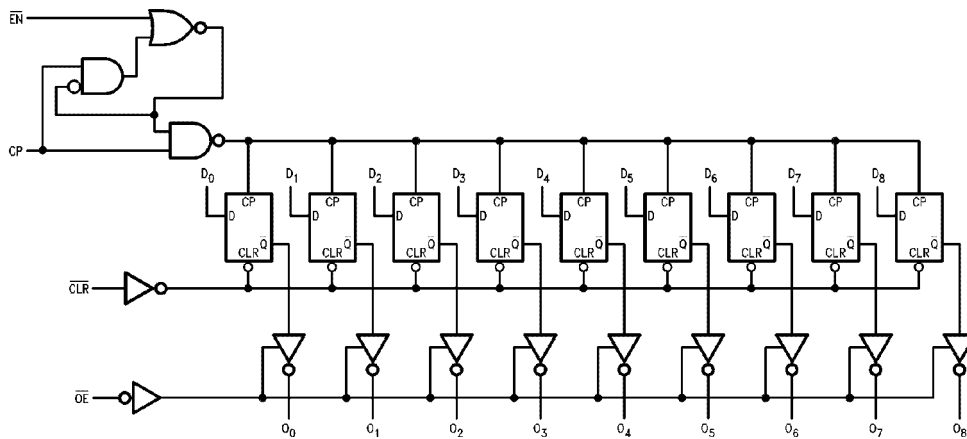

TL/F/9596-5

Please note that this diagram is provided only for the understanding of logic operations and should not be used to estimate propagation delays.

Absolute Maximum Ratings (Note 1)

If Military/Aerospace specified devices are required, please contact the National Semiconductor Sales Office/Distributors for availability and specifications.

Storage Temperature	–65°C to +150°C
Ambient Temperature under Bias	–55°C to +125°C
Junction Temperature under Bias Plastic	–55°C to +175°C –55°C to +150°C
V _{CC} Pin Potential to Ground Pin	–0.5V to +7.0V
Input Voltage (Note 2)	–0.5V to +7.0V
Input Current (Note 2)	–30 mA to +5.0 mA
Voltage Applied to Output in HIGH State (with V _{CC} = 0V)	
Standard Output	–0.5V to V _{CC}
TRI-STATE Output	–0.5V to +5.5V
Current Applied to Output in LOW State (Max)	twice the rated I _{OL} (mA)

Note 1: Absolute maximum ratings are values beyond which the device may be damaged or have its useful life impaired. Functional operation under these conditions is not implied.

Note 2: Either voltage limit or current limit is sufficient to protect inputs.

Recommended Operating Conditions

Free Air Ambient Temperature	
Military	–55°C to +125°C
Commercial	0°C to +70°C
Supply Voltage	
Military	+4.5V to +5.5V
Commercial	+4.5V to +5.5V

DC Electrical Characteristics

Symbol	Parameter	54F/74F			Units	V _{CC}	Conditions
		Min	Typ	Max			
V _{IH}	Input HIGH Voltage	2.0			V		Recognized as a HIGH Signal
V _{IL}	Input LOW Voltage			0.8	V		Recognized as a LOW Signal
V _{CD}	Input Clamp Diode Voltage			–1.2	V	Min	I _{IN} = –18 mA
V _{OH}	Output HIGH Voltage	54F 10% V _{CC} 54F 10% V _{CC} 74F 10% V _{CC} 74F 10% V _{CC} 74F 5% V _{CC} 74F 5% V _{CC}	2.5 2.4 2.5 2.4 2.7 2.7		V	Min	I _{OH} = –1 mA I _{OH} = –3 mA I _{OH} = –1 mA I _{OH} = –3 mA I _{OH} = –1 mA I _{OH} = –3 mA
V _{OL}	Output LOW Voltage	54F 10% V _{CC} 74F 10% V _{CC}		0.5 0.5	V	Min	I _{OL} = 20 mA I _{OL} = 24 mA
I _{IH}	Input HIGH Current	54F 74F		20.0 5.0	μA	Max	V _{IN} = 2.7V
I _{BVI}	Input HIGH Current Breakdown Test	54F 74F		100 7.0	μA	Max	V _{IN} = 7.0V
I _{CEX}	Output HIGH Leakage Current	54F 74F		250 50	μA	Max	V _{OUT} = V _{CC}
V _{ID}	Input Leakage Test	74F	4.75		V	0.0	I _{ID} = 1.9 μA All Other Pins Grounded
I _{OD}	Output Leakage Circuit Current	74F		3.75	μA	0.0	V _{IOD} = 150 mV All Other Pins Grounded
I _{IL}	Input LOW Current			–0.6 –1.2	mA mA	Max Max	V _{IN} = 0.5V (\overline{OE} , \overline{CLR} , \overline{EN}) V _{IN} = 0.5V (CP)
I _{OZH}	Output Leakage Current			50	μA	Max	V _{OUT} = 2.7V
I _{OZL}	Output Leakage Current			–50	μA	Max	V _{OUT} = 0.5V
I _{OS}	Output Short-Circuit Current		–60	–150	mA	Max	V _{OUT} = 0V
I _{ZZ}	Buss Drainage Test			500	μA	0.0V	V _{OUT} = 5.25V
I _{CCZ}	Power Supply Current		75	100	mA	Max	V _O = HIGH Z

AC Electrical Characteristics

Symbol	Parameter	74F			54F		74F		Units
		$T_A = +25^\circ\text{C}$ $V_{CC} = +5.0\text{V}$ $C_L = 50\text{ pF}$			$T_A, V_{CC} = \text{Mil}$ $C_L = 50\text{ pF}$		$T_A, V_{CC} = \text{Com}$ $C_L = 50\text{ pF}$		
		Min	Typ	Max	Min	Max	Min	Max	
f_{max}	Maximum Clock Frequency	100	160		60		70		MHz
t_{PLH}	Propagation Delay	2.0	5.6	9.5	2.0	10.5	2.0	10.5	ns
t_{PHL}	CP to O_n	2.0	5.2	9.5	2.0	10.5	2.0	10.5	
t_{PHL}	Propagation Delay $\overline{\text{CLR}}$ to O_n	4.0	7.1	12.0	4.0	13.0	4.0	13.0	ns
t_{PZH}	Output Enable Time	2.0	5.8	10.5	2.0	13.0	2.0	11.5	ns
t_{PZL}	$\overline{\text{OE}}$ to O_n	2.0	5.5	10.5	2.0	13.0	2.0	11.5	
t_{PHZ}	Output Disable Time	1.5	2.9	7.0	1.0	7.5	1.5	7.5	
t_{PLZ}	$\overline{\text{OE}}$ to O_n	1.5	2.7	7.0	1.0	7.5	1.5	7.5	

AC Operating Requirements

Symbol	Parameter	74F		54F		74F		Units
		$T_A = +25^\circ\text{C}$ $V_{CC} = +5.0\text{V}$		$T_A, V_{CC} = \text{Mil}$		$T_A, V_{CC} = \text{Com}$		
		Min	Max	Min	Max	Min	Max	
$t_s(\text{H})$	Setup Time, HIGH or LOW	2.5		4.0		3.0		ns
$t_s(\text{L})$	D_n to CP	2.5		4.0		3.0		
$t_h(\text{H})$	Hold Time, HIGH or LOW	2.5		2.5		2.5		ns
$t_h(\text{L})$	D_n to CP	2.5		2.5		2.5		
$t_s(\text{H})$	Setup Time, HIGH or LOW	4.5		5.0		5.0		ns
$t_s(\text{L})$	$\overline{\text{EN}}$ to CP	2.5		3.0		3.0		
$t_h(\text{H})$	Hold Time, HIGH or LOW	2.0		3.0		2.0		ns
$t_h(\text{L})$	$\overline{\text{EN}}$ to CP	0		1.0		0		
$t_w(\text{H})$	CP Pulse Width	5.0		6.0		6.0		ns
$t_w(\text{L})$	HIGH or LOW	5.0		6.0		6.0		ns
$t_w(\text{L})$	$\overline{\text{CLR}}$ Pulse Width, LOW	5.0		5.0		5.0		ns
t_{rec}	$\overline{\text{CLR}}$ Recovery Time	5.0		5.0		5.0		ns

Ordering Information

The device number is used to form part of a simplified purchasing code where the package type and temperature range are defined as follows:

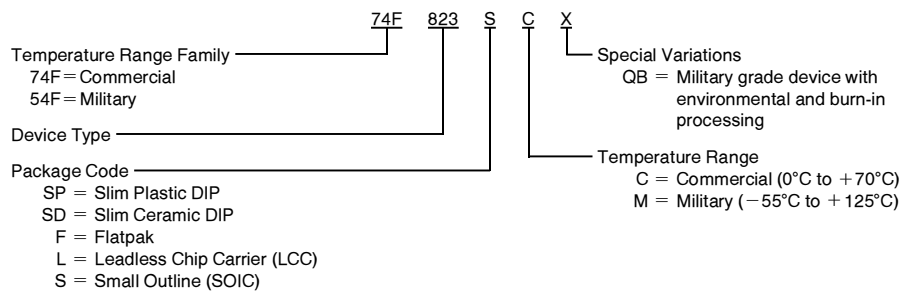

Physical Dimensions inches (millimeters)

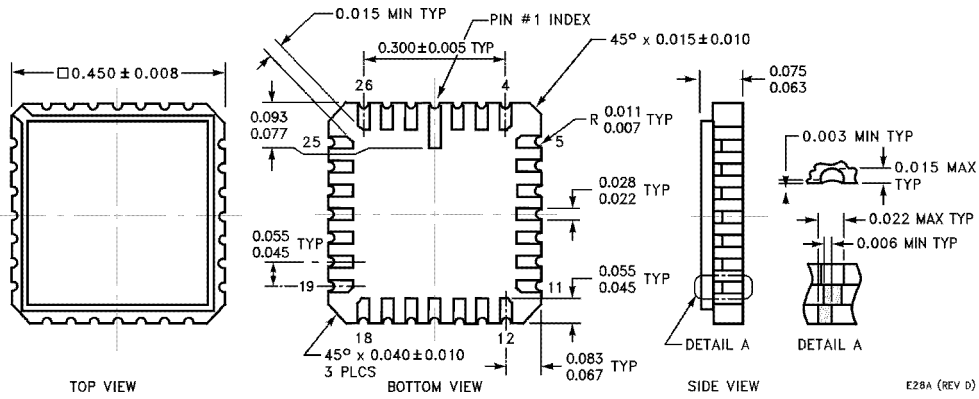

28-Lead Ceramic Leadless Chip Carrier, Type C (L)
NS Package Number E28A

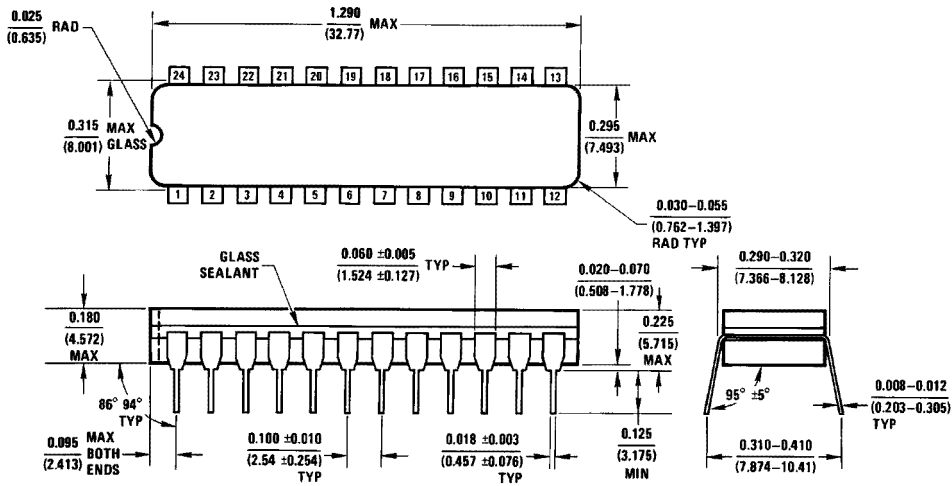

24-Lead (0.300" Wide) Ceramic Dual-In-Line Package (SD)
NS Package Number J24F

Physical Dimensions inches (millimeters) (Continued)

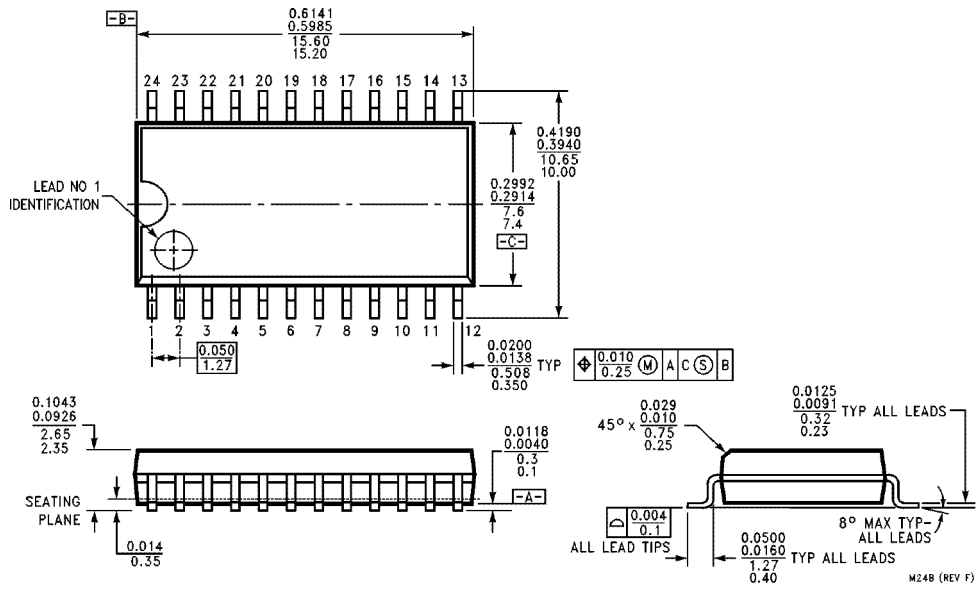

**24-Lead (0.300" Wide) Molded Small Outline Package, JEDEC (S)
NS Package Number M24B**

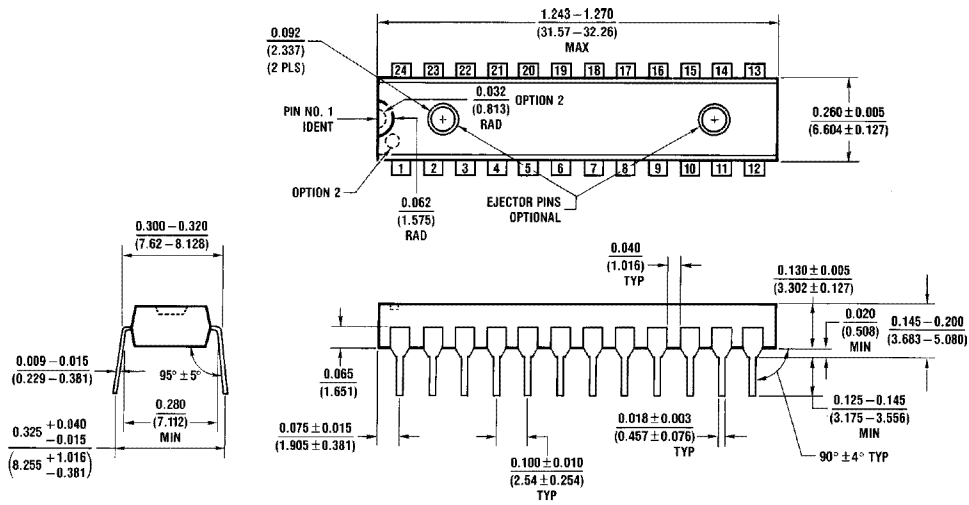

**24-Lead (0.300" Wide) Molded Dual-In-Line Package (SP)
NS Package Number N24C**

Physical Dimensions inches (millimeters) (Continued)

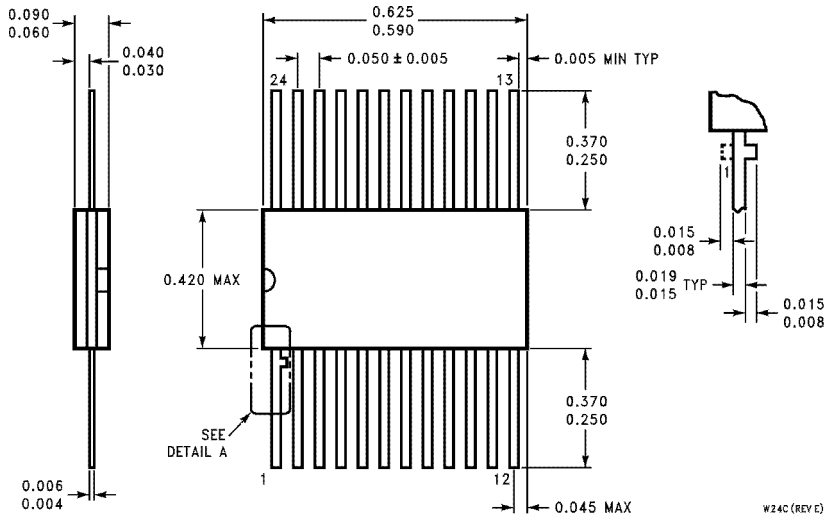

**24-Lead Ceramic Flatpak (F)
NS Package Number W24C**

LIFE SUPPORT POLICY

NATIONAL'S PRODUCTS ARE NOT AUTHORIZED FOR USE AS CRITICAL COMPONENTS IN LIFE SUPPORT DEVICES OR SYSTEMS WITHOUT THE EXPRESS WRITTEN APPROVAL OF THE PRESIDENT OF NATIONAL SEMICONDUCTOR CORPORATION. As used herein:

1. Life support devices or systems are devices or systems which, (a) are intended for surgical implant into the body, or (b) support or sustain life, and whose failure to perform, when properly used in accordance with instructions for use provided in the labeling, can be reasonably expected to result in a significant injury to the user.
2. A critical component is any component of a life support device or system whose failure to perform can be reasonably expected to cause the failure of the life support device or system, or to affect its safety or effectiveness.



National Semiconductor Corporation
2900 Semiconductor Drive
P.O. Box 58090
Santa Clara, CA 95052-8090
Tel: 1(800) 272-9959
TWX: (910) 339-9240

National Semiconductor GmbH
Livry-Gargan-Str. 10
D-82256 Fürstenfeldbruck
Germany
Tel: (61-41) 35-0
Telex: 527649
Fax: (61-41) 35-1

National Semiconductor Japan Ltd.
Sumitomo Chemical
Engineering Center
Bldg. 7F
1-7-1, Nakase, Mihama-Ku
Chiba-City,
Chiba Prefecture 261
Tel: (043) 299-2300
Fax: (043) 299-2500

National Semiconductor Hong Kong Ltd.
13th Floor, Straight Block,
Ocean Centre, 5 Canton Rd.
Tsimshatsui, Kowloon
Hong Kong
Tel: (852) 2737-1600
Fax: (852) 2736-9960

National Semiconductores Do Brazil Ltda.
Rue Deputado Lacorda Franco
120-3A
Sao Paulo-SP
Brazil 05418-000
Tel: (55-11) 212-5066
Telex: 391-1131931 NSBR BR
Fax: (55-11) 212-1181

National Semiconductor (Australia) Pty, Ltd.
Building 16
Business Park Drive
Monash Business Park
Nottingham, Melbourne
Victoria 3168 Australia
Tel: (3) 558-9999
Fax: (3) 558-9998

National does not assume any responsibility for use of any circuitry described, no circuit patent licenses are implied and National reserves the right at any time without notice to change said circuitry and specifications.