

## 54F/74F74 Dual D-Type Positive Edge-Triggered Flip-Flop

### General Description

The 'F74 is a dual D-type flip-flop with Direct Clear and Set inputs and complementary (Q,  $\bar{Q}$ ) outputs. Information at the input is transferred to the outputs on the positive edge of the clock pulse. Clock triggering occurs at a voltage level of the clock pulse and is not directly related to the transition time of the positive-going pulse. After the Clock Pulse input threshold voltage has been passed, the Data input is locked out and information present will not be transferred to the outputs until the next rising edge of the Clock Pulse input.

#### Asynchronous Inputs:

LOW input to  $\bar{S}_D$  sets Q to HIGH level  
 LOW input to  $\bar{C}_D$  sets Q to LOW level  
 Clear and Set are independent of clock  
 Simultaneous LOW on  $\bar{C}_D$  and  $\bar{S}_D$   
 makes both Q and  $\bar{Q}$  HIGH

### Features

- Guaranteed 4000V minimum ESD protection

Commercial	Military	Package Number	Package Description
74F74PC		N14A	14-Lead (0.300" Wide) Molded Dual-In-Line
	54F74DM (Note 2)	J14A	14-Lead Ceramic Dual-In-Line
74F74SC (Note 1)		M14A	14-Lead (0.150" Wide) Molded Small Outline, JEDEC
74F74SJ (Note 1)		M14D	14-Lead (0.300" Wide) Molded Small Outline, EIAJ
	54F74FM (Note 2)	W14B	14-Lead Cerpack
	54F74LM (Note 2)	E20A	20-Lead Ceramic Leadless Chip Carrier, Type C

**Note 1:** Devices also available in 13" reel. Use Suffix = SCX.

**Note 2:** Military grade device with environmental and burn-in processing. Use suffix = DMOB, FMQB and LMQB.

### Logic Symbols

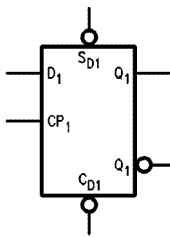

TL/F/9469-3

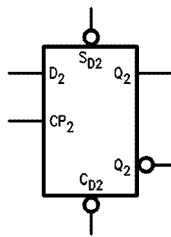

TL/F/9469-4

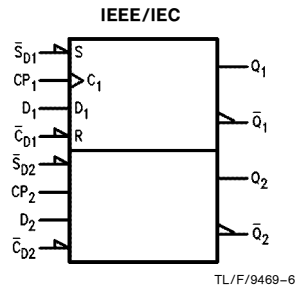

TL/F/9469-6

TRI-STATE® is a registered trademark of National Semiconductor Corporation.

## Connection Diagrams

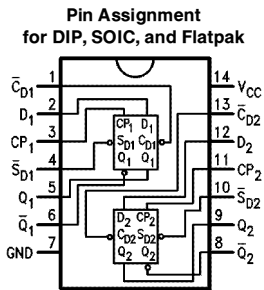

TL/F/9469-1

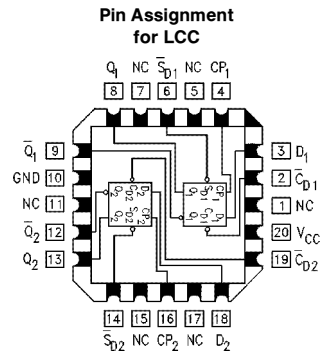

TL/F/9469-2

## Unit Loading/Fan Out

Pin Names	Description	54F/74F	
		U.L. HIGH/LOW	Input $I_{IH}/I_{IL}$ Output $I_{OH}/I_{OL}$
$D_1, D_2$	Data Inputs	1.0/1.0	20 $\mu A$ / -0.6 mA
$CP_1, CP_2$	Clock Pulse Inputs (Active Rising Edge)	1.0/1.0	20 $\mu A$ / -0.6 mA
$\overline{C}_{D1}, \overline{C}_{D2}$	Direct Clear Inputs (Active LOW)	1.0/3.0	20 $\mu A$ / -1.8 mA
$\overline{S}_{D1}, \overline{S}_{D2}$	Direct Set Inputs (Active LOW)	1.0/3.0	20 $\mu A$ / -1.8 mA
$Q_1, \overline{Q}_1, Q_2, \overline{Q}_2$	Outputs	50/33.3	-1 mA / 20 mA

## Truth Table

Inputs				Outputs	
$\overline{S}_D$	$\overline{C}_D$	CP	D	Q	$\overline{Q}$
L	H	X	X	H	L
H	L	X	X	L	H
L	L	X	X	H	H
H	H	$\swarrow$	h	H	L
H	H	$\swarrow$	l	L	H
H	H	L	X	$Q_0$	$\overline{Q}_0$

H (h) = HIGH Voltage Level

L (l) = LOW Voltage Level

X = Immaterial

$Q_0$  = Previous Q ( $\overline{Q}$ ) before LOW-to-HIGH Clock Transition

Lower case letters indicate the state of the referenced input or output one setup time prior to the LOW-to-HIGH clock transition.

## Logic Diagram

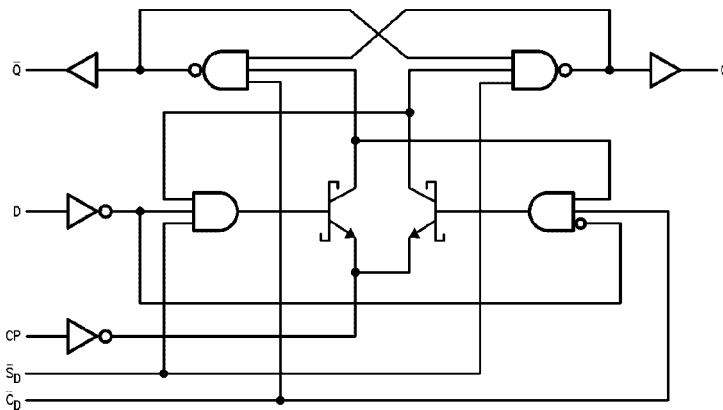

TL/F/9469-5

Please note that this diagram is provided only for the understanding of logic operations and should not be used to estimate propagation delays.

## Absolute Maximum Ratings (Note 1)

If Military/Aerospace specified devices are required, please contact the National Semiconductor Sales Office/Distributors for availability and specifications.

Storage Temperature	-65°C to +150°C
Ambient Temperature under Bias	-55°C to +125°C
Junction Temperature under Bias	-55°C to +175°C
Plastic	-55°C to +150°C

V<sub>CC</sub> Pin Potential to Ground Pin -0.5V to +7.0V

Input Voltage (Note 2) -0.5V to +7.0V

Input Current (Note 2) -30 mA to +5.0 mA

Voltage Applied to Output in HIGH State (with V<sub>CC</sub> = 0V)  
 Standard Output -0.5V to V<sub>CC</sub>  
 TRI-STATE® Output -0.5V to +5.5V

Current Applied to Output in LOW State (Max) twice the rated I<sub>OL</sub> (mA)

ESD Last Passing Voltage (Min) 4000V

**Note 1:** Absolute maximum ratings are values beyond which the device may be damaged or have its useful life impaired. Functional operation under these conditions is not implied.

**Note 2:** Either voltage limit or current limit is sufficient to protect inputs.

## Recommended Operating Conditions

Free Air Ambient Temperature	
Military	-55°C to +125°C
Commercial	0°C to +70°C
Supply Voltage	
Military	+4.5V to +5.5V
Commercial	+4.5V to +5.5V

## DC Electrical Characteristics

Symbol	Parameter	54F/74F			Units	V <sub>CC</sub>	Conditions
		Min	Typ	Max			
V <sub>IH</sub>	Input HIGH Voltage	2.0			V		Recognized as a HIGH Signal
V <sub>IL</sub>	Input LOW Voltage			0.8	V		Recognized as a LOW Signal
V <sub>CD</sub>	Input Clamp Diode Voltage			-1.2	V	Min	I <sub>IN</sub> = -18 mA
V <sub>OH</sub>	Output HIGH Voltage	54F 10% V <sub>CC</sub> 74F 10% V <sub>CC</sub> 74F 5% V <sub>CC</sub>	2.5 2.5 2.7		V	Min	I <sub>OH</sub> = -1 mA I <sub>OH</sub> = -1 mA I <sub>OH</sub> = -1 mA
V <sub>OL</sub>	Output LOW Voltage	54F 10% V <sub>CC</sub> 74F 10% V <sub>CC</sub>		0.5 0.5	V	Min	I <sub>OL</sub> = 20 mA I <sub>OL</sub> = 20 mA
I <sub>IH</sub>	Input HIGH Current	54F 74F		20.0 5.0	μA	Max	V <sub>IN</sub> = 2.7V
I <sub>BVI</sub>	Input HIGH Current Breakdown Test	54F 74F		100 7.0	μA	Max	V <sub>IN</sub> = 7.0V
I <sub>CEX</sub>	Output HIGH Leakage Current	54F 74F		250 50	μA	Max	V <sub>OUT</sub> = V <sub>CC</sub>
V <sub>ID</sub>	Input Leakage Test	74F	4.75		V	0.0	I <sub>ID</sub> = 1.9 μA All Other Pins Grounded
I <sub>OD</sub>	Output Leakage Circuit Current	74F		3.75	μA	0.0	V <sub>IOD</sub> = 150 mV All Other Pins Grounded
I <sub>IL</sub>	Input LOW Current			-0.6 -1.8	mA	Max	V <sub>IN</sub> = 0.5V (D, CP) V <sub>IN</sub> = 0.5V (C <sub>D</sub> , S <sub>D</sub> )
I <sub>OS</sub>	Output Short-Circuit Current		-60	-150	mA	Max	V <sub>OUT</sub> = 0V
I <sub>CC</sub>	Power Supply Current		10.5	16.0	mA	Max	

### AC Electrical Characteristics

Symbol	Parameter	74F			54F		74F		Units
		T <sub>A</sub> = +25°C V <sub>CC</sub> = +5.0V C <sub>L</sub> = 50 pF			T <sub>A</sub> , V <sub>CC</sub> = Mil C <sub>L</sub> = 50 pF		T <sub>A</sub> , V <sub>CC</sub> = Com C <sub>L</sub> = 50 pF		
		Min	Typ	Max	Min	Max	Min	Max	
f <sub>max</sub>	Maximum Clock Frequency	100	125	6.8	80	8.5	100	7.8	MHz
t <sub>PLH</sub> t <sub>PHL</sub>	Propagation Delay CP <sub>n</sub> to Q <sub>n</sub> or $\overline{Q}_n$	3.8	5.3	8.0	3.8	10.5	3.8	9.2	ns
t <sub>PLH</sub> t <sub>PHL</sub>	Propagation Delay $\overline{C}_{Dn}$ or $\overline{S}_{Dn}$ to Q <sub>n</sub> or $\overline{Q}_n$	3.2	4.6	9.0	3.2	11.5	3.2	10.5	ns

### AC Operating Requirements

Symbol	Parameter	74F		54F		74F		Units
		T <sub>A</sub> = +25°C V <sub>CC</sub> = +5.0V		T <sub>A</sub> , V <sub>CC</sub> = Mil		T <sub>A</sub> , V <sub>CC</sub> = Com		
		Min	Max	Min	Max	Min	Max	
t <sub>s</sub> (H) t <sub>s</sub> (L)	Setup Time, HIGH or LOW D <sub>n</sub> to CP <sub>n</sub>	2.0	3.0	3.0	4.0	2.0	3.0	ns
t <sub>h</sub> (H) t <sub>h</sub> (L)	Hold Time, HIGH or LOW D <sub>n</sub> to CP <sub>n</sub>	1.0	2.0	2.0	2.0	1.0	1.0	ns
t <sub>w</sub> (H) t <sub>w</sub> (L)	CP <sub>n</sub> Pulse Width HIGH or LOW	4.0	5.0	4.0	6.0	4.0	5.0	ns
t <sub>w</sub> (L)	$\overline{C}_{Dn}$ or $\overline{S}_{Dn}$ Pulse Width LOW	4.0	4.0	4.0	4.0	4.0	4.0	ns
t <sub>rec</sub>	Recovery Time $\overline{C}_{Dn}$ or $\overline{S}_{Dn}$ to CP	2.0	3.0	3.0	3.0	2.0	2.0	ns

## Ordering Information

The device number is used to form part of a simplified purchasing code where the package type and temperature range are defined as follows:

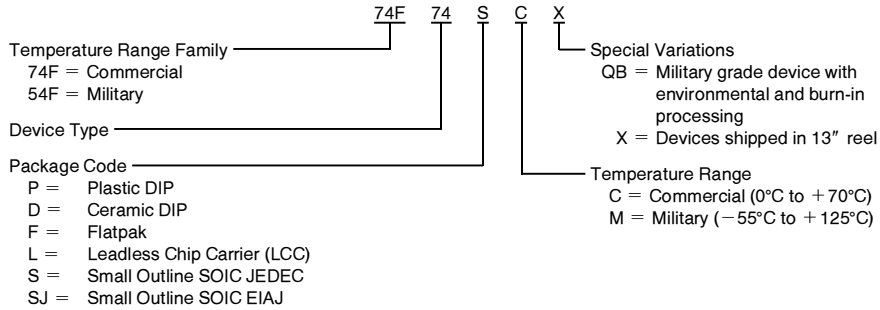

## Physical Dimensions inches (millimeters)

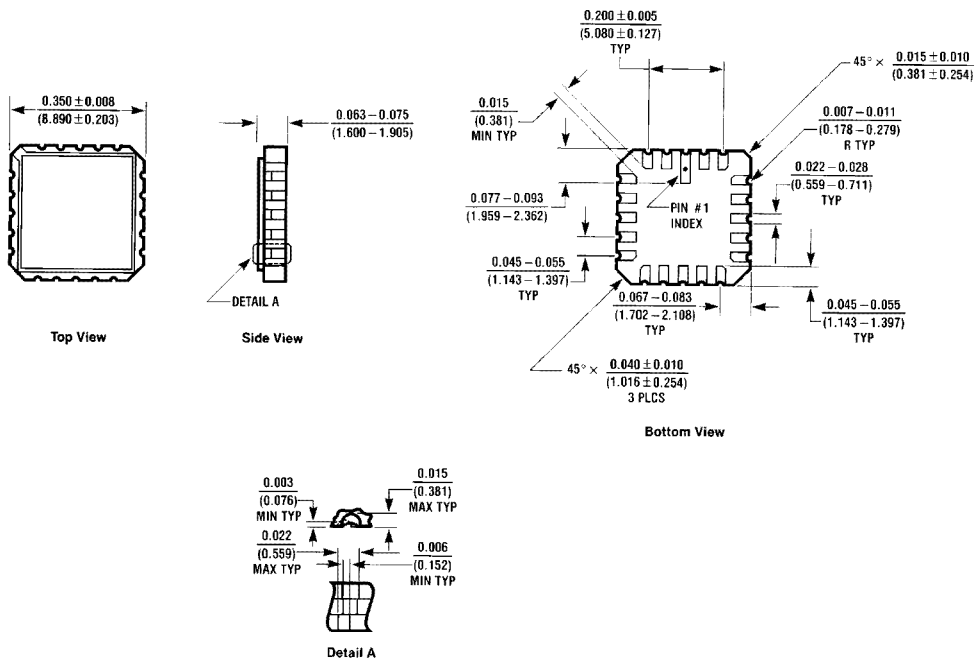

20-Lead Ceramic Leadless Chip Carrier (L)  
NS Package Number E20A

E20A (REV D)

**Physical Dimensions** inches (millimeters) (Continued)

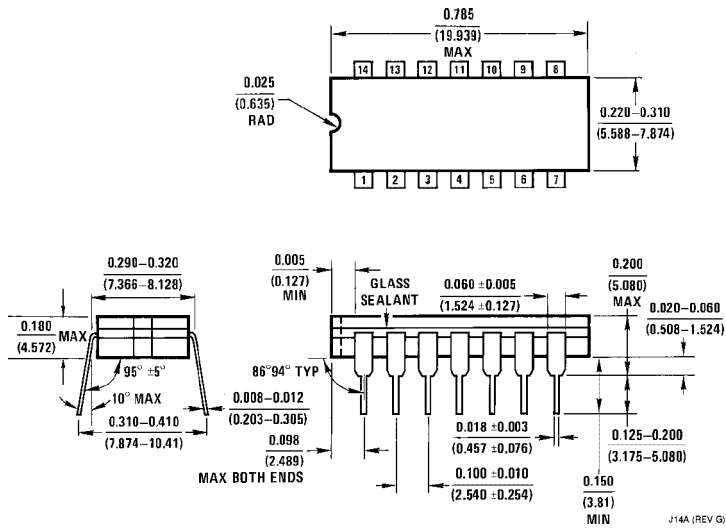

**14-Lead Ceramic Dual-In-Line Package (D)**  
NS Package Number J14A

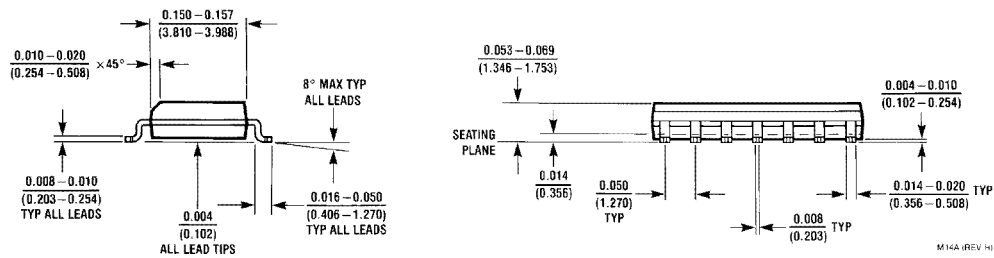
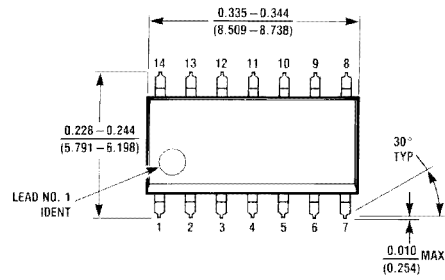

**14-Lead (0.150" Wide) Molded Small Outline, JEDEC (S)**  
NS Package Number M14A

**Physical Dimensions** inches (millimeters) (Continued)

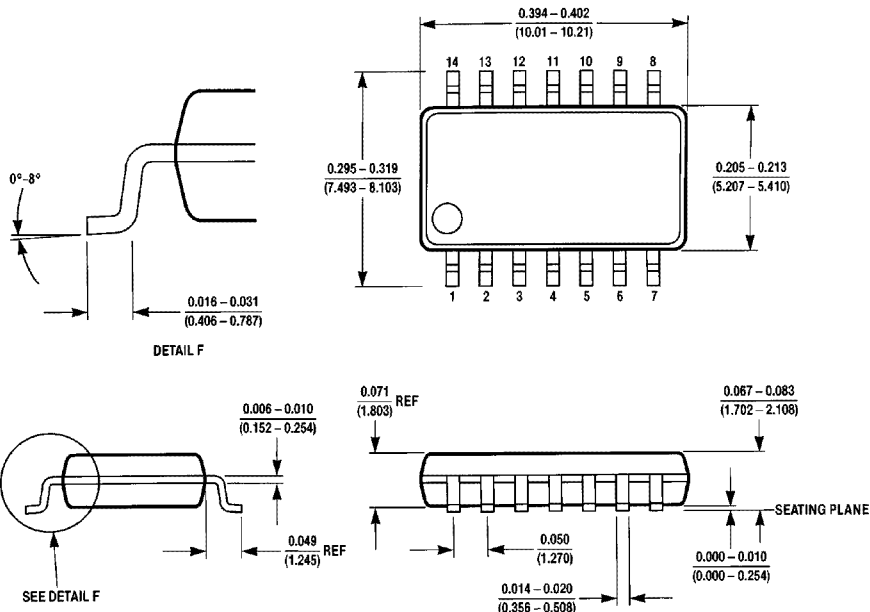

**14-Lead (0.300" Wide) Molded Small Outline, EIAJ (SJ)  
NS Package Number M14D**

M14D (REV A)

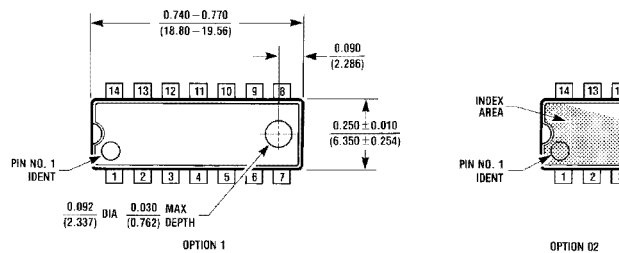

**OPTION 1**

**OPTION 02**

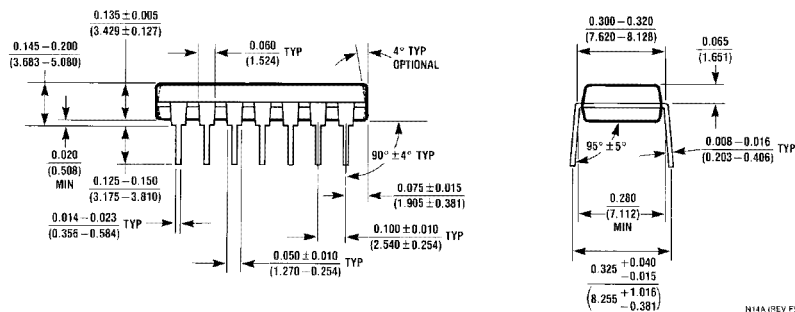

**14-Lead (0.300" Wide) Molded Dual-In-Line Package (P)  
NS Package Number N14A**

N14A (REV F)

**Physical Dimensions** inches (millimeters) (Continued)

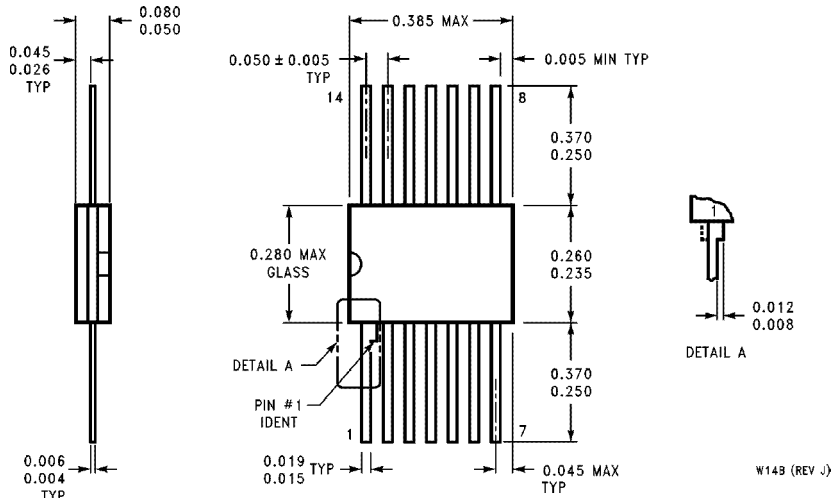

**14-Lead Ceramic Flatpak (F)  
NS Package Number W14B**

**LIFE SUPPORT POLICY**

NATIONAL'S PRODUCTS ARE NOT AUTHORIZED FOR USE AS CRITICAL COMPONENTS IN LIFE SUPPORT DEVICES OR SYSTEMS WITHOUT THE EXPRESS WRITTEN APPROVAL OF THE PRESIDENT OF NATIONAL SEMICONDUCTOR CORPORATION. As used herein:

1. Life support devices or systems are devices or systems which, (a) are intended for surgical implant into the body, or (b) support or sustain life, and whose failure to perform, when properly used in accordance with instructions for use provided in the labeling, can be reasonably expected to result in a significant injury to the user.
2. A critical component is any component of a life support device or system whose failure to perform can be reasonably expected to cause the failure of the life support device or system, or to affect its safety or effectiveness.

 <p><b>National Semiconductor Corporation</b> 2900 Semiconductor Drive P.O. Box 58090 Santa Clara, CA 95052-8090 Tel: 1(800) 272-9959 TWX: (910) 339-9240</p>	<p><b>National Semiconductor GmbH</b> Livry-Gargan-Str. 10 D-82256 Fürstenfeldbruck Germany Tel: (61-41) 35-0 Telex: 527649 Fax: (61-41) 35-1</p>	<p><b>National Semiconductor Japan Ltd.</b> Sumitomo Chemical Engineering Center Bldg. 7F 1-7-1, Nakase, Mihama-Ku Chiba-City, Chiba Prefecture 261 Tel: (043) 299-2300 Fax: (043) 299-2500</p>	<p><b>National Semiconductor Hong Kong Ltd.</b> 13th Floor, Straight Block, Ocean Centre, 5 Canton Rd. Tsimshatsui, Kowloon Hong Kong Tel: (852) 2737-1600 Fax: (852) 2736-9960</p>	<p><b>National Semicondutores Do Brazil Ltda.</b> Rue Deputado Lacorda Franco 120-3A Sao Paulo-SP Brazil 05418-000 Tel: (55-11) 212-5066 Telex: 391-1131931 NSBR BR Fax: (55-11) 212-1181</p>	<p><b>National Semiconductor (Australia) Pty, Ltd.</b> Building 16 Business Park Drive Monash Business Park Nottingham, Melbourne Victoria 3168 Australia Tel: (3) 558-9999 Fax: (3) 558-9998</p>
--	---	---	---	---	---

National does not assume any responsibility for use of any circuitry described, no circuit patent licenses are implied and National reserves the right at any time without notice to change said circuitry and specifications.