

54F/74F109 Dual JK Positive Edge-Triggered Flip-Flop

General Description

The 'F109 consists of two high-speed, completely independent transition clocked JK flip-flops. The clocking operation is independent of rise and fall times of the clock waveform. The JK design allows operation as a D flip-flop (refer to 'F74 data sheet) by connecting the J and \bar{K} inputs.

Asynchronous Inputs:

LOW input to \bar{S}_D sets Q to HIGH level

LOW input to \bar{C}_D sets Q to LOW level

Clear and Set are independent of clock

Simultaneous LOW on \bar{C}_D and \bar{S}_D makes both Q and \bar{Q} HIGH

Features

- Guaranteed 4000V minimum ESD protection.

Ordering Code: See Section 0

Commercial	Military	Package Number	Package Description
74F109PC		N16E	16-Lead (0.300" Wide) Molded Dual-in-Line
	54F109DM (Note 2)	J16A	16-Lead Ceramic Dual-in-Line
74F109SC (Note 1)		M16A	16-Lead (0.150" Wide) Molded Small Outline, JEDEC
74F109SJ (Note 1)		M16D	16-Lead (0.300" Wide) Molded Small Outline, EIAJ
	54F109FM (Note 2)	W16A	16-Lead Cerpack
	54F109LM (Note 2)	E20A	16-Lead Ceramic Leadless Chip Carrier, Type C

Note 1: Devices also available in 13" reel. Use suffix = SCX and SJX.

Note 2: Military grade device with environmental and burn-in processing. Use suffix = DMQB, FMQB and LMQB.

Logic Symbols

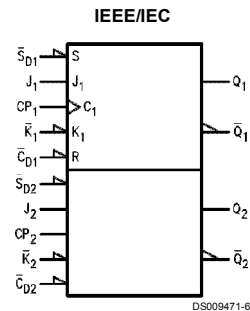
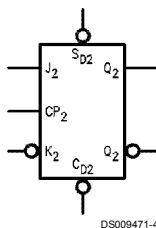
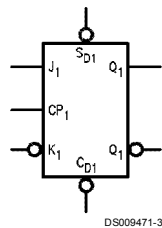

FAST® and TRI-STATE® are registered trademarks of National Semiconductor Corporation.

Connection Diagrams

Pin Assignment
for DIP, SOIC and Flatpak

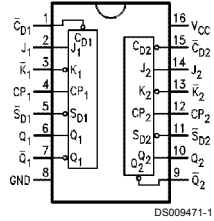

DS009471-1

Pin Assignment
for LCC

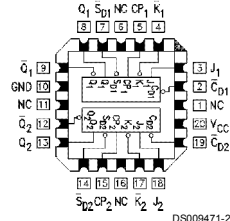

DS009471-2

Unit Loading/Fan Out

See Section 0 for U.L. definitions

Pin Names	Description	54F/74F	
		U.L. HIGH/LOW	Input I_{IH}/I_{IL} Output I_{OH}/I_{OL}
$J_1, J_2, \bar{K}_1, \bar{K}_2$	Data Inputs	1.0/1.0	20 μ A/-0.6 mA
CP_1, CP_2	Clock Pulse Inputs (Active Rising Edge)	1.0/1.0	20 μ A/-0.6 mA
$\bar{C}_{D1}, \bar{C}_{D2}$	Direct Clear Inputs (Active LOW)	1.0/3.0	20 μ A/-1.8 mA
$\bar{S}_{D1}, \bar{S}_{D2}$	Direct Set Inputs (Active LOW)	1.0/3.0	20 μ A/-1.8 mA
$Q_1, Q_2, \bar{Q}_1, \bar{Q}_2$	Outputs	50/33.3	-1 mA/20 mA

DSXXX

Truth Table

Inputs					Outputs	
\bar{S}_D	\bar{C}_D	CP	J	\bar{K}	Q	\bar{Q}
L	H	X	X	X	H	L
H	L	X	X	X	L	H
L	L	X	X	X	H	H
H	H	↗	l	l	L	H
H	H	↗	h	l	Toggle	
H	H	↗	l	h	Q_0	\bar{Q}_0
H	H	↗	h	h	H	L
H	H	L	X	X	Q_0	\bar{Q}_0

H (h) = HIGH Voltage Level

L (l) = LOW Voltage Level

↗ = LOW-to-HIGH Transition

X = Immaterial

Q_0 (\bar{Q}_0) = Before LOW-to-HIGH Transition of Clock

Lower case letters indicate the state of the referenced output one setup time prior to the LOW-to-HIGH clock transition.

Logic Diagram (One Half Shown)

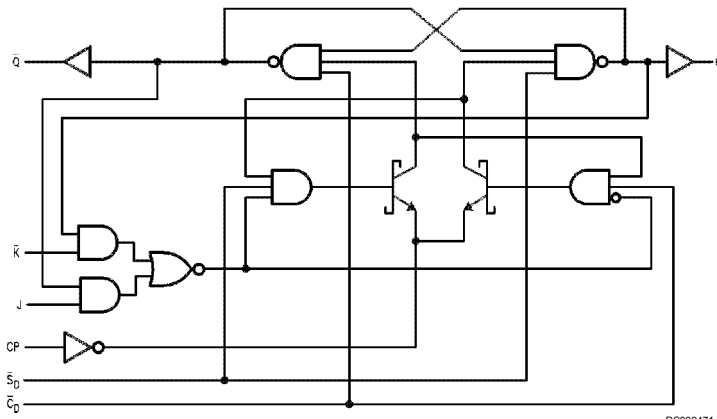

DS009471-5

Please note that this diagram is provided only for the understanding of logic operations and should not be used to estimate propagation delays.

Absolute Maximum Ratings (Note 3)

If Military/Aerospace specified devices are required, please contact the National Semiconductor Sales Office/Distributors for availability and specifications.

Storage Temperature	-65°C to +150°C
Ambient Temperature under Bias	-55°C to +125°C
Junction Temperature under Bias	-55°C to +175°C
Plastic	-55°C to +150°C
V _{CC} Pin Potential to Ground Pin	-0.5V to +7.0V
Input Voltage (Note 4)	-0.5V to +7.0V
Input Current (Note 4)	-30 mA to +5.0 mA
Voltage Applied to Output in HIGH State (with V _{CC} = 0V)	
Standard Output	-0.5V to V _{CC}
TRI-STATE® Output	-0.5V to +5.5V

Current Applied to Output in LOW State (Max) twice the rated I_{OL} (mA)
ESD Last Passing Voltage (Min) 4000V

Recommended Operating Conditions

Free Air Ambient Temperature	
Military	-55°C to +125°C
Commercial	0°C to +70°C
Supply Voltage	
Military	+4.5V to +5.5V
Commercial	+4.5V to +5.5V

Note 3: Absolute maximum ratings are values beyond which the device may be damaged or have its useful life impaired. Functional operation under these conditions is not implied.

Note 4: Either voltage limit or current limit is sufficient to protect inputs.

DC Electrical Characteristics

Symbol	Parameter	54F/74F			Units	V _{CC}	Conditions
		Min	Typ	Max			
V _{IH}	Input HIGH Voltage	2.0			V		Recognized as a HIGH Signal
V _{IL}	Input LOW Voltage				V		Recognized as a LOW Signal
V _{CD}	Input Clamp Diode Voltage				V	Min	I _{IN} = -18 mA
V _{OH}	Output HIGH Voltage	54F 10% V _{CC}	2.5		V	Min	I _{OH} = -1 mA
		74F 10% V _{CC}	2.5				
		74F 5% V _{CC}	2.7				
V _{OL}	Output LOW Voltage	54F 10% V _{CC}			V	Min	I _{OL} = 20 mA
		74F 10% V _{CC}	0.5				
I _{IH}	Input HIGH Current	54F	20.0		μA	Max	V _{IN} = 2.7V
		74F	5.0				
I _{BVI}	Input HIGH Current Breakdown Test	54F	100		μA	Max	V _{IN} = 7.0V
		74F	7.0				
I _{CEX}	Output HIGH Leakage Current	54F	250		μA	Max	V _{OUT} = V _{CC}
		74F	50				
V _{ID}	Input Leakage Test	74F	4.75		V	0.0	I _{ID} = 1.9 μA All Other Pins Grounded
I _{OD}	Output Leakage Circuit Current	74F	3.75		μA	0.0	V _{IOD} = 150 mV All Other Pins Grounded
I _{IL}	Input LOW Current			-0.6	mA	Max	V _{IN} = 0.5V (J _n , K _n)
				-1.8			
I _{OS}	Output Short-Circuit Current			-60	mA	Max	V _{OUT} = 0V
				-150			
I _{CC}	Power Supply Current			11.7	mA	Max	CP = 0V
				17.0			

AC Electrical Characteristics

See Section 0 for Waveforms and Load Configurations

Symbol	Parameter	74F			54F		74F		Units	Fig. No.
		T _A = +25°C V _{CC} = +5.0V C _L = 50 pF			T _A , V _{CC} = Mil C _L = 50 pF		T _A , V _{CC} = Com C _L = 50 pF			
		Min	Typ	Max	Min	Max	Min	Max		
f _{max}	Maximum Clock Frequency	100	125		70		90	MHz	◆◆◆	

AC Electrical Characteristics (Continued)

See Section 0 for Waveforms and Load Configurations

Symbol	Parameter	74F			54F		74F		Units	Fig. No.
		$T_A = +25^\circ\text{C}$ $V_{CC} = +5.0\text{V}$ $C_L = 50\text{ pF}$			$T_A, V_{CC} = \text{Mil}$ $C_L = 50\text{ pF}$		$T_A, V_{CC} = \text{Com}$ $C_L = 50\text{ pF}$			
		Min	Typ	Max	Min	Max	Min	Max		
t_{PLH}	Propagation Delay	3.8	5.3	7.0	3.8	9.0	3.8	8.0	ns	◆◆◆
t_{PHL}	CP_n to Q_n or \bar{Q}_n	4.4	6.2	8.0	4.4	10.5	4.4	9.2	ns	◆◆◆
t_{PLH}	Propagation Delay	3.2	5.2	7.0	3.2	9.0	3.2	8.0	ns	◆◆◆
t_{PHL}	\bar{C}_{Dn} or \bar{S}_{Dn} to Q_n or \bar{Q}_n	3.5	7.0	9.0	3.5	11.5	3.5	10.5		

AC Operating Requirements

See Section 0 for Waveforms

Symbol	Parameter	74F		54F		74F		Units	Fig. No.
		$T_A = +25^\circ\text{C}$ $V_{CC} = +5.0\text{V}$		$T_A, V_{CC} = \text{Mil}$		$T_A, V_{CC} = \text{Com}$			
		Min	Max	Min	Max	Min	Max		
$t_s(H)$	Setup Time, HIGH or LOW	3.0		3.0		3.0		ns	◆◆◆
$t_s(L)$	J_n or \bar{K}_n to CP_n	3.0		4.0		3.0			
$t_h(H)$	Hold Time, HIGH or LOW	1.0		1.0		1.0			
$t_h(L)$	J_n or \bar{K}_n to CP_n	1.0		1.0		1.0		ns	◆◆◆
$t_w(H)$	CP_n Pulse Width	4.0		4.0		4.0			
$t_w(L)$	HIGH or LOW	5.0		5.0		5.0		ns	◆◆◆
$t_w(L)$	\bar{C}_{Dn} or \bar{S}_{Dn} Pulse Width, LOW	4.0		4.0		4.0			
t_{rec}	Recovery Time \bar{C}_{Dn} or \bar{S}_{Dn} to CP	2.0		2.0		2.0		ns	◆◆◆

Ordering Information

The device number is used to form part of a simplified purchasing code where the package type and temperature range are defined as follows:

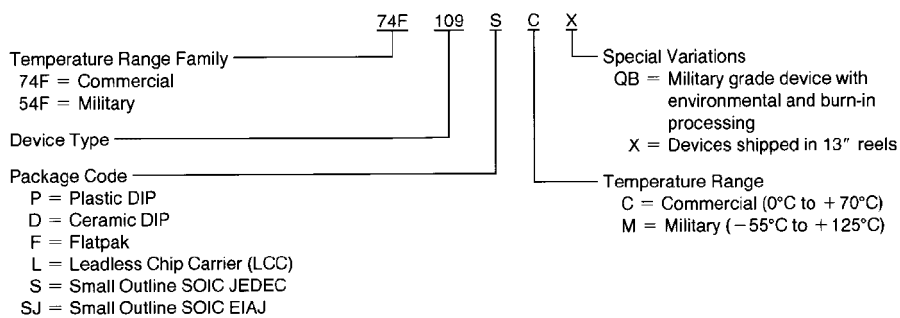

DS009471-7

THIS PAGE IS IGNORED IN THE DATABOOK

+

|

+

+

Physical Dimensions inches (millimeters) unless otherwise noted

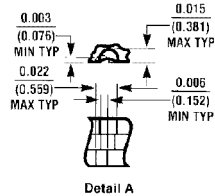
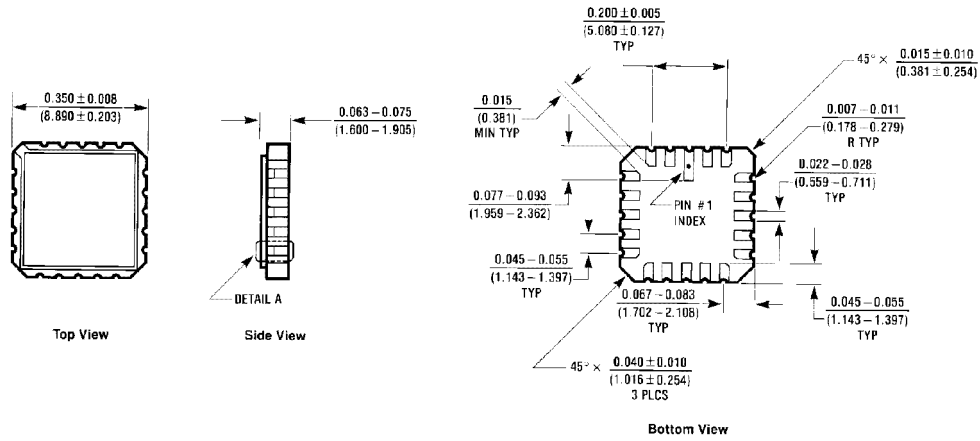

**20-Lead Ceramic Leadless Chip Carrier (L)
 NS Package Number E20A**

EQA/REV D

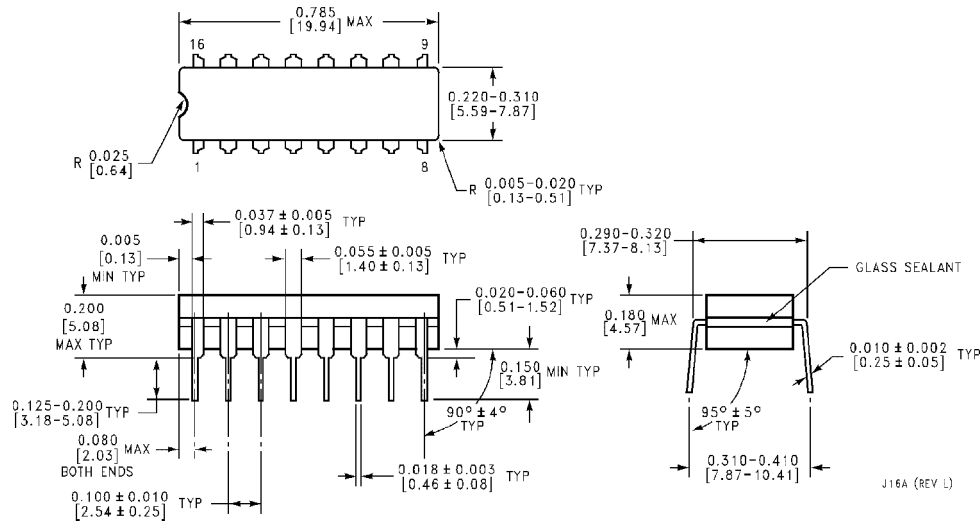

**16-Lead Ceramic Dual-In-Line Package (D)
 NS Package Number J16A**

J16A (REV L)

Physical Dimensions inches (millimeters) unless otherwise noted (Continued)

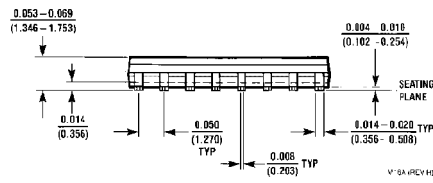
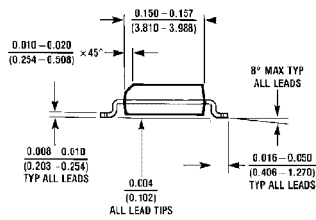
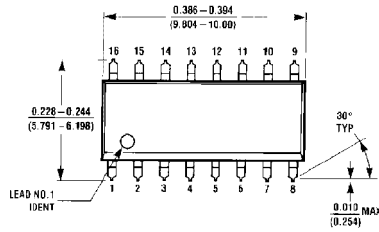

16-Lead (0.150" Wide) Molded Small Outline Package, JEDEC (S)
NS Package Number M16A

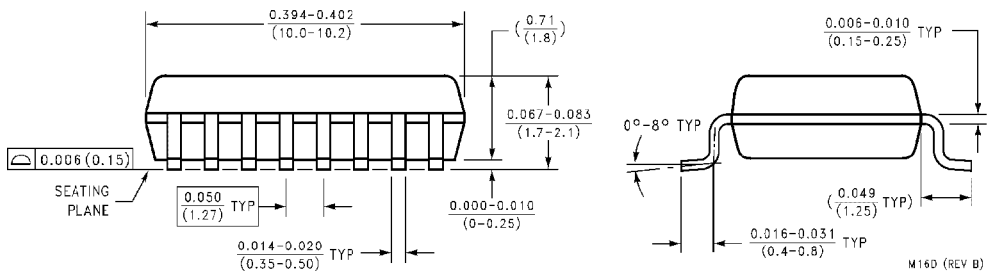
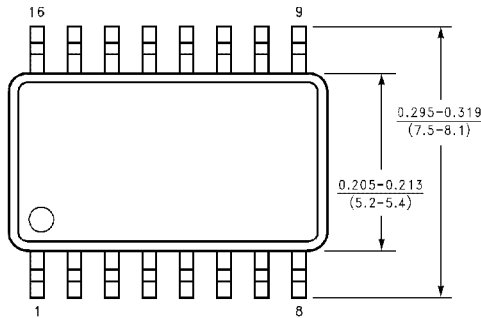

16-Lead (0.300" Wide) Molded Small Outline Package, EIAJ (SJ)
NS Package Number M16D

Physical Dimensions inches (millimeters) unless otherwise noted (Continued)

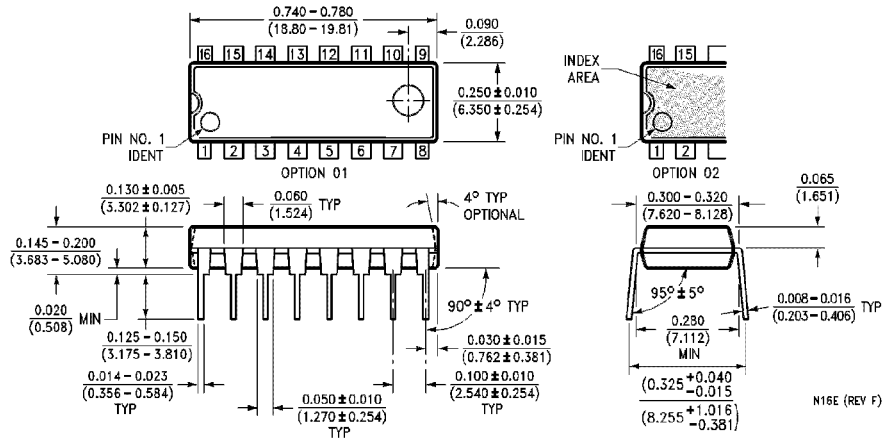

16-Lead (0.300" Wide) Molded Dual-In-Line Package (P)
NS Package Number N16E

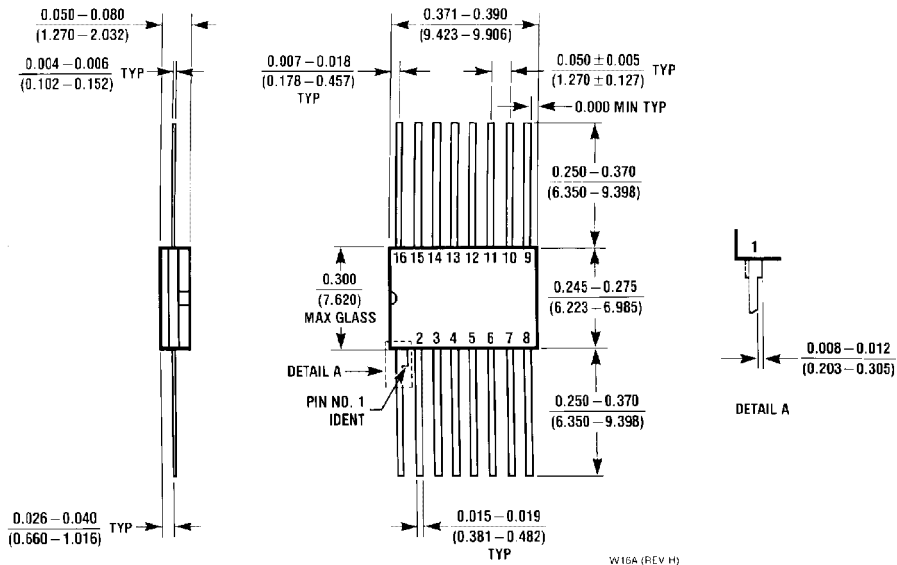

16-Lead Ceramic Flatpak (F)
NS Package Number W16A

LIFE SUPPORT POLICY

NATIONAL'S PRODUCTS ARE NOT AUTHORIZED FOR USE AS CRITICAL COMPONENTS IN LIFE SUPPORT DEVICES OR SYSTEMS WITHOUT THE EXPRESS WRITTEN APPROVAL OF THE PRESIDENT OF NATIONAL SEMICONDUCTOR CORPORATION. As used herein:

1. Life support devices or systems are devices or systems which, (a) are intended for surgical implant into the body, or (b) support or sustain life, and whose failure to perform when properly used in accordance with instructions for use provided in the labeling, can be reasonably expected to result in a significant injury to the user.
2. A critical component in any component of a life support device or system whose failure to perform can be reasonably expected to cause the failure of the life support device or system, or to affect its safety or effectiveness.



National Semiconductor Corporation
Americas
Tel: 1-800-272-9959
Fax: 1-800-737-7018
Email: support@nsc.com

www.national.com

National Semiconductor Europe
Fax: +49 (0) 1 80-530 85 86
Email: europe.support@nsc.com
Deutsch Tel: +49 (0) 1 80-530 85 85
English Tel: +49 (0) 1 80-532 78 32
Français Tel: +49 (0) 1 80-532 93 58
Italiano Tel: +49 (0) 1 80-534 16 80

National Semiconductor Hong Kong Ltd.
13th Floor, Straight Block,
Ocean Centre, 5 Canton Rd.
Tsimshatsui, Kowloon
Hong Kong
Tel: (852) 2737-1600
Fax: (852) 2736-9960

National Semiconductor Japan Ltd.
Tel: 81-3-5620-6175
Fax: 81-3-5620-6179

National does not assume any responsibility for use of any circuitry described, no circuit patent licenses are implied and National reserves the right at any time without notice to change said circuitry and specifications.