

# DATA SHEET

For a complete data sheet, please also download:

- The IC04 LOCMOS HE4000B Logic Family Specifications HEF, HEC
- The IC04 LOCMOS HE4000B Logic Package Outlines/Information HEF, HEC

## **HEF4541B** **MSI** Programmable timer

Product specification  
File under Integrated Circuits, IC04

January 1995

# Programmable timer

# HEF4541B MSI

### DESCRIPTION

The HEF4541B is a programmable timer which consists of a 16-stage binary counter, an integrated oscillator to be used with external timing components, an automatic power-on reset and output control logic. The frequency of the oscillator is determined by the external components  $R_t$  and  $C_t$  within the frequency range 1 Hz to 100 kHz. This oscillator may be replaced by an external clock signal at input RS, the timer advances on the positive-going transition of RS. A LOW on the auto reset input ( $\overline{AR}$ ) and a LOW on the master reset input (MR) enables the internal power-on reset. A HIGH level at input MR resets the counter independent on all other inputs. Resetting

disables the oscillator to provide no active power dissipation.

A HIGH at input  $\overline{AR}$  turns off the power-on reset to provide a low quiescent power dissipation of the timer. The 16-stage counter divides the oscillator frequency by  $2^8$ ,  $2^{10}$ ,  $2^{13}$  or  $2^{16}$  depending on the state of the address inputs ( $A_0$ ,  $A_1$ ). The divided oscillator frequency is available at output O. The phase input (PH) features a complementary output signal. If the mode select input (MODE) is LOW or HIGH the timer can be used respectively as a single transition timer or  $2^n$  frequency divider.

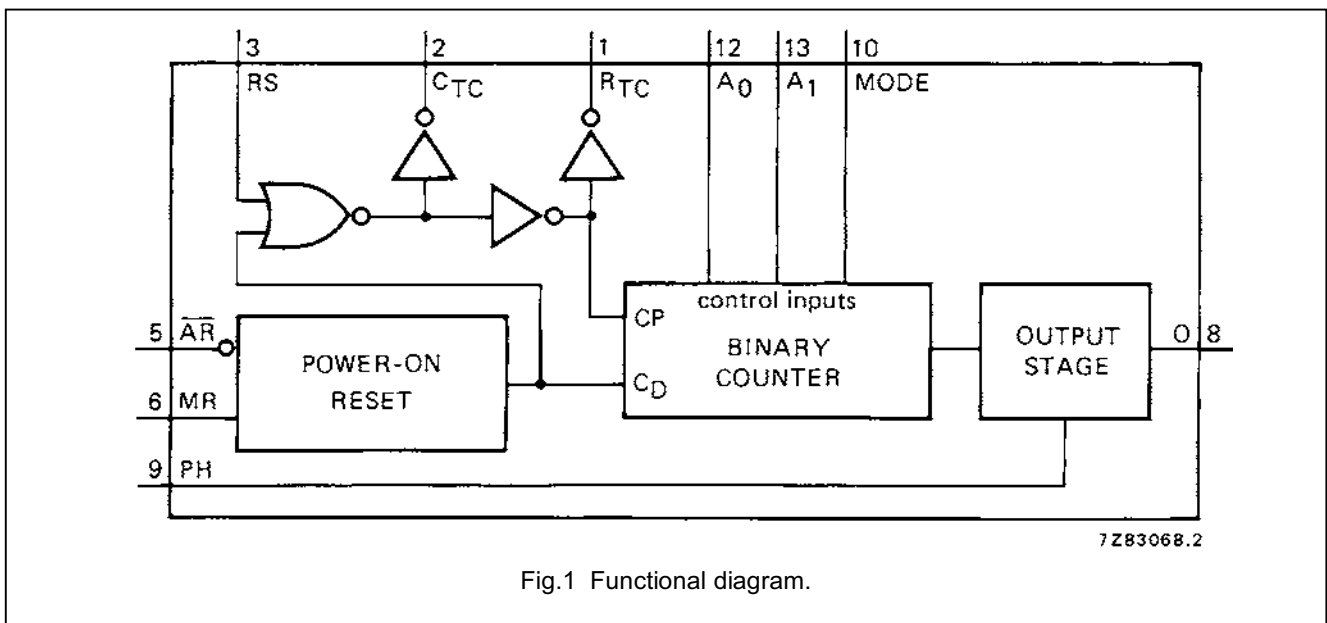

Fig.1 Functional diagram.

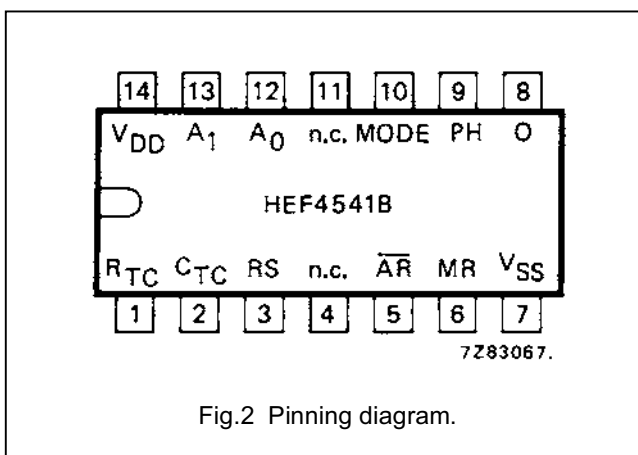

Fig.2 Pinning diagram.

- HEF4541BP(N): 14-lead DIL; plastic (SOT27-1)
  - HEF4541BD(F): 14-lead DIL; ceramic (cerdip) (SOT73)
  - HEF4541BT(D): 14-lead SO; plastic (SOT108-1)
- ( ): Package Designator North America

### FAMILY DATA, I<sub>DD</sub> LIMITS category MSI

See Family Specifications

Programmable timer

HEF4541B  
MSI

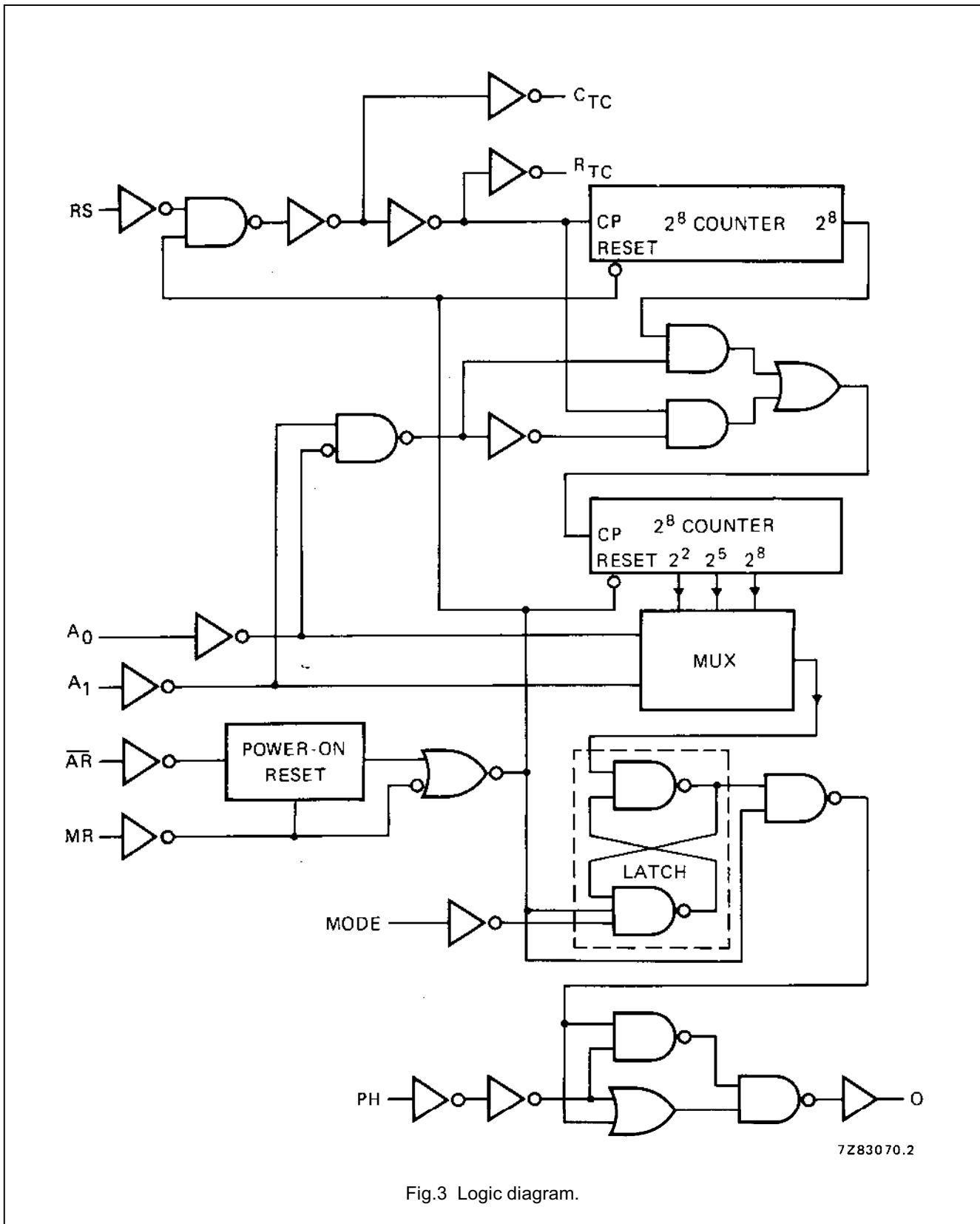

7Z83070.2

Fig.3 Logic diagram.



Programmable timer

HEF4541B  
MSI

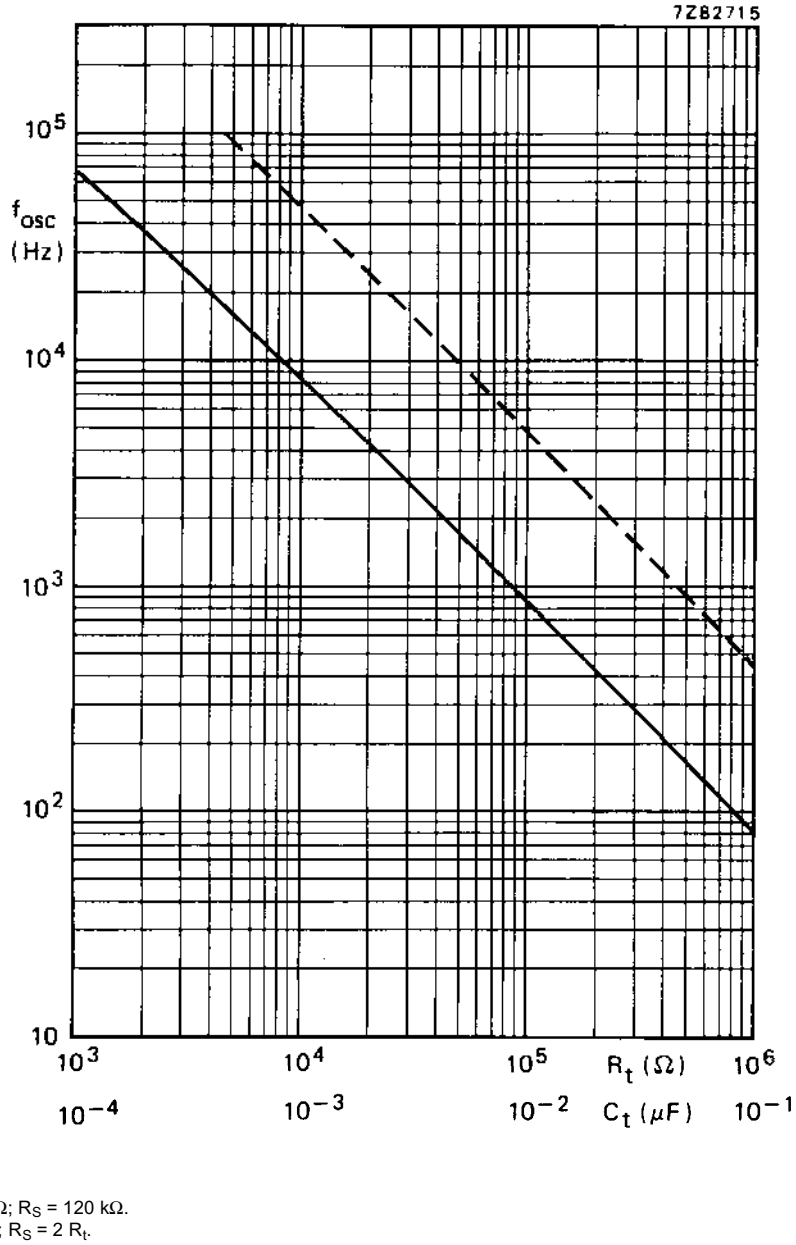
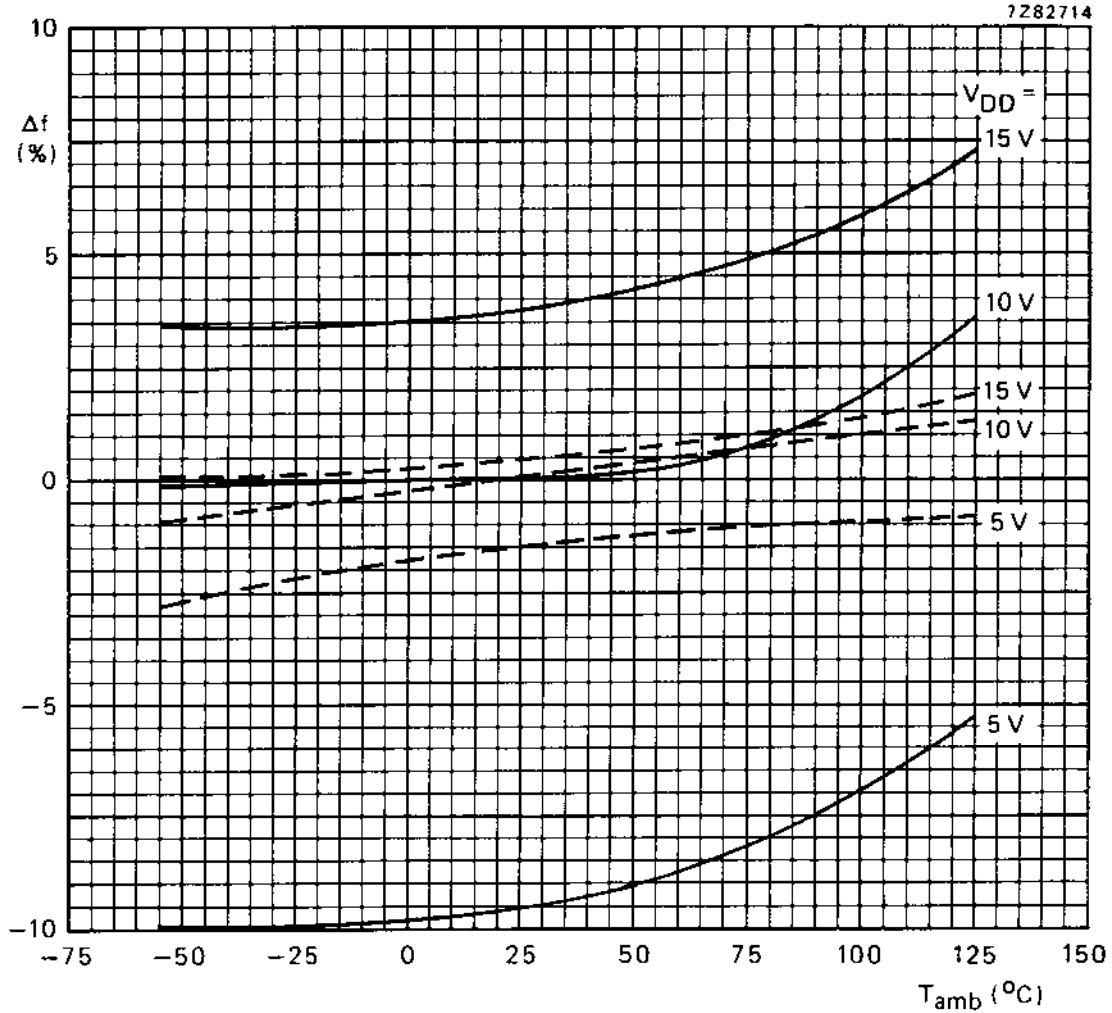

Fig.5 RC oscillator frequency as a function of  $R_t$  and  $C_t$  at  $V_{DD} = 5$  to  $15 \text{ V}$ ;  $T_{amb} = 25 \text{ }^\circ\text{C}$ .

Programmable timer

HEF4541B  
MSI



—  $R_t = 56\text{ k}\Omega$ ;  $C_t = 1\text{ nF}$ ;  $R_S = 0$ .  
 ---  $R_t = 56\text{ k}\Omega$ ;  $C_t = 1\text{ nF}$ ;  $R_S = 120\text{ k}\Omega$ .

Fig.6 Frequency deviation ( $\Delta f$ ) as a function of ambient temperature; referenced at :  $f_{osc}$  at  $T_{amb} = 25\text{ }^\circ\text{C}$  and  $V_{DD} = 10\text{ V}$ .

## Programmable timer

HEF4541B  
MSI

## DC CHARACTERISTICS

 $V_{SS} = 0\text{ V}$ 

	$V_{DD}$ V	$V_{OL}$ V	$V_{OH}$ V	SYMBOL	$T_{amb}$ (°C)							
					-40		+25		+85			
					MIN.	MAX.	MIN.	TYP.	MAX.	MIN.	MAX.	
Supply current	5				-	80	-	20	80	-	230	$\mu\text{A}$
power-on reset enabled (note)	10			$I_D$	-	750	-	250	600	-	700	$\mu\text{A}$
	15				-	1600	-	500	1300	-	1500	$\mu\text{A}$
Supply voltage for automatic reset initialization (note)				$V_{DD}$	-	-	8,5	5	-	-	-	V
Output current HIGH; $C_{TC}$ , $R_{TC}$	5		4,6		0,5	-	0,4	-	-	0,3	-	mA
	10		9,5	$-I_{OH}$	1,4	-	1,2	-	-	0,95	-	mA
	15		13,5		4,8	-	4,0	-	-	3,2	-	mA
	5		2,5	$-I_{OH}$	1,4	-	1,2	-	-	0,95	-	mA
Output current LOW; $C_{TC}$ , $R_{TC}$	5	0,4			0,33	-	0,27	-	-	0,20	-	mA
	10	0,5		$I_{OL}$	1,00	-	0,85	-	-	0,68	-	mA
	15	1,5			3,20	-	2,70	-	-	2,30	-	mA

## Note

- All inputs at 0 V or  $V_{DD}$ ; except input  $\overline{AR}$  = input MR = 0 V (power-on reset active).

## AC CHARACTERISTICS

 $V_{SS} = 0\text{ V}$ ;  $T_{amb} = 25\text{ °C}$ ; input transition times  $\leq 20\text{ ns}$ 

	$V_{DD}$ V	TYPICAL FORMULA FOR P ( $\mu\text{W}$ ) <sup>(1)</sup>
Dynamic power dissipation per package (P)	5	1 300 $f_i + f_o C_L V_{DD}^2$
	10	5 300 $f_i + f_o C_L V_{DD}^2$
	15	12 000 $f_i + f_o C_L V_{DD}^2$
Total power dissipation when using the on-chip oscillator (P)	5	1 300 $f_{osc} + f_o C_L V_{DD}^2 + 2C_t V_{DD}^2 f_{osc} + 10 V_{DD}$
	10	5 300 $f_{osc} + f_o C_L V_{DD}^2 + 2C_t V_{DD}^2 f_{osc} + 100 V_{DD}$
	15	12 000 $f_{osc} + f_o C_L V_{DD}^2 + 2C_t V_{DD}^2 f_{osc} + 400 V_{DD}$

## Notes

- where:

 $f_i$  = input frequency (MHz) $f_o$  = output frequency (MHz) $C_L$  = load capacitance (pF) $V_{DD}$  = supply voltage (V) $C_t$  = timing capacitance (pF) $f_{osc}$  = oscillator frequency (MHz)

## Programmable timer

HEF4541B  
MSI

## AC CHARACTERISTICS

 $V_{SS} = 0\text{ V}$ ;  $T_{amb} = 25\text{ °C}$ ;  $C_L = 50\text{ pF}$ ; input transition times  $\leq 20\text{ ns}$ 

	$V_{DD}$ V	SYMBOL	MIN.	TYP.	MAX.	TYPICAL EXTRAPOLATION FORMULA	
Propagation delays RS → O	$2^8$ selected	$t_{PHL}$ ; $t_{PLH}$		375	750	ns	$348\text{ ns} + (0,55\text{ ns/pF}) C_L$
			HIGH to LOW	150	300	ns	$139\text{ ns} + (0,23\text{ ns/pF}) C_L$
			LOW to HIGH	110	220	ns	$102\text{ ns} + (0,16\text{ ns/pF}) C_L$
	$2^{10}$ selected	$t_{PHL}$ ; $t_{PLH}$		425	850	ns	$398\text{ ns} + (0,55\text{ ns/pF}) C_L$
			HIGH to LOW	165	330	ns	$154\text{ ns} + (0,23\text{ ns/pF}) C_L$
			LOW to HIGH	120	240	ns	$112\text{ ns} + (0,16\text{ ns/pF}) C_L$
	$2^{13}$ selected	$t_{PHL}$ ; $t_{PLH}$		510	1020	ns	$483\text{ ns} + (0,55\text{ ns/pF}) C_L$
			HIGH to LOW	190	380	ns	$179\text{ ns} + (0,23\text{ ns/pF}) C_L$
			LOW to HIGH	135	270	ns	$127\text{ ns} + (0,16\text{ ns/pF}) C_L$
	$2^{16}$ selected	$t_{PHL}$ ; $t_{PLH}$		575	1150	ns	$548\text{ ns} + (0,55\text{ ns/pF}) C_L$
			HIGH to LOW	210	420	ns	$199\text{ ns} + (0,23\text{ ns/pF}) C_L$
			LOW to HIGH	150	300	ns	$142\text{ ns} + (0,16\text{ ns/pF}) C_L$
Minimum clock pulse width; LOW	5	$t_{WRSL}$	60	30	ns		
	10		30	15	ns		
	15		24	12	ns		
Minimum reset pulse width; HIGH	5	$t_{WMRH}$	60	30	ns		
	10		30	15	ns		
	15		24	12	ns		
Maximum clock pulse frequency	5	$f_{max}$	8	16	MHz		
	10		15	30	MHz		
	15		18	36	MHz		
Oscillator frequency	5	$f_{osc}$		90	kHz	$R_t = 5\text{ k}\Omega$	
	10			90	kHz	$C_t = 1\text{ nF}$	
	15			90	kHz	$R_S = 10\text{ k}\Omega$	
Oscillator frequency	5	$f_{osc}$		8	kHz	$R_t = 56\text{ k}\Omega$	
	10			8	kHz	$C_t = 1\text{ nF}$	
	15			8	kHz	$R_S = 120\text{ k}\Omega$	