

DESCRIPTION

The new GMT38HC4x devices are high performance BiCMOS current mode Pulse Width Modulation (“PWM”) controllers, which are compatible with the industry standard UC384x devices as well as all HC and C type devices. These integrated circuits are designed to provide plug-in replacement in virtually all standard power supply applications. The GMT38HC4x family of controllers offers many improvements over the industry standard products. Features such as lower start-up and operational currents as well as improved voltage reference characteristics enhance overall system performance. The output drive stage has also been designed to significantly reduce shoot-through conduction, resulting in more efficient high frequency operation. The GMT38HC4x devices are offered in MSOP, SOIC and DIP packages. A 14-pin package option is offered for users who require separate power and ground.

FEATURES

- Guaranteed operation from -40°C to +85°C.
- High frequency operation up to 500 kHz.
- Low shoot-through current. Typically 4.0 mA at 500 kHz.
- Low operational current of 2.6 mA typical, 5.0 mA maximum.
- Low start-up current 50 uA typical.
- Improved reference performance.
- Pin-for-pin compatibility to industry standard devices.
- HC performance in an MSOP package.
- Current sense delay time 50 nS typical.
- ESD protected to 2000 Volts.

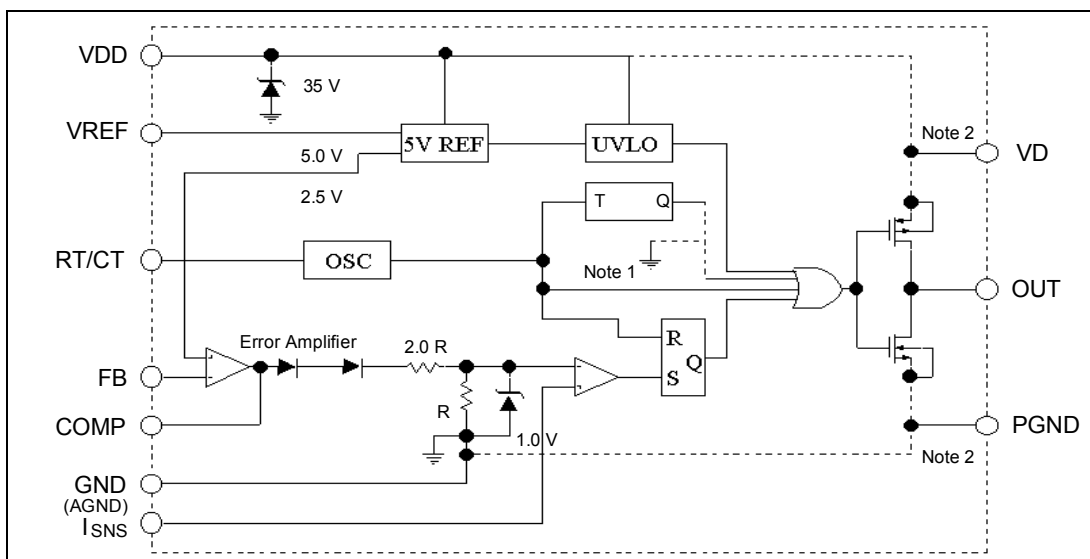

Note 1: Toggle FF disconnected for GMT38HC42/3 Versions Only. Extra OR-gate input is Grounded. Toggle FF connected to Extra OR-gate input for GMT38HC4/5 Versions Only.

Note 2: 14 Pin Package Only.

GMT38HC4x

CURRENT MODE PWM CONTROLLERS

Table 1: ABSOLUTE MAXIMUM RATINGS

Zener Current (VDD)	30 mA	Operating Junction Temperature	150°C
VDD VD	20 V 20 V	ESD Rating (Note A)	2000 V
VISNS	-0.3 V TO 5.5 V	Package Thermal Resistance (Junction to Ambient)	
VFB Output Current	-0.3 V TO 5.5 V +/- 1.0 A	8 Pin Plastic Dip	125°C/W
Lead Temperature (soldering, 10 sec)	+300°C	8-Pin MSOP 8-Pin SOIC	250°C/W 170°C/W
Storage Temperature (Ambient)	-65°C to +150°C	14-Pin Plastic DIP 14-Pin SOIC	90°C/W 145°C/W
Note A: Mil Std. 883 D Human Body Model Method 3015.7 at 25°C			

Table 2: DEVICE SELECTION GUIDE

8 Pin Plastic Dip	8-Pin MSOP	8-Pin SOIC	14-Pin Plastic DIP	14-Pin SOIC
38HC42N08	38HC42R08	38HC42M08	38HC42N14	38HC42M14
38HC43N08	38HC43R08	38HC43M08	38HC43N14	38HC43M14
38HC44N08	38HC44R08	38HC44M08	38HC44N14	38HC44M14
38HC45N08	38HC45R08	38HC45M08	38HC45N14	38HC45M14

NOTE: -40° C to 85° C Operating temperature range

GMT38HC4x

CURRENT MODE PWM CONTROLLERS

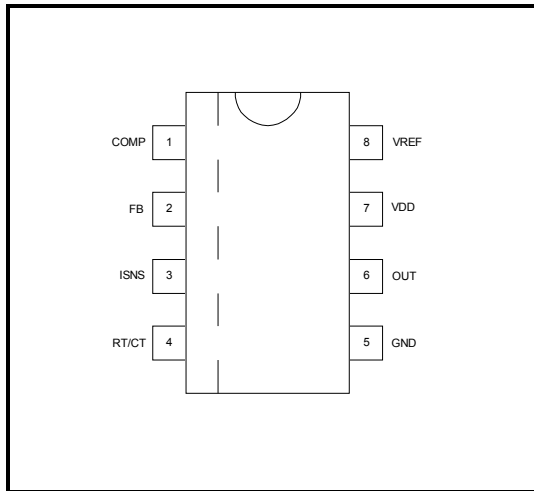

GMT38HC4x
8 Pin MSOP
8 Pin DIP
8 Pin SOIC

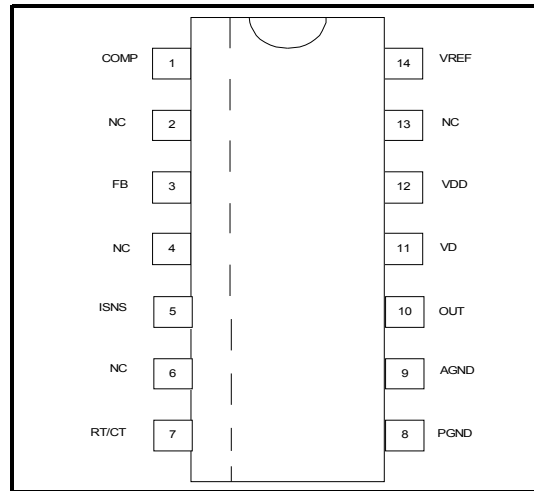

GMT38HC4x
14 Pin DIP
14 Pin SOIC

Table 3: PIN DESCRIPTION

FUNCTION	8-PIN PIN NO.	14-PIN PIN NO.	DESCRIPTION
COMP	1	1	Compensation pin/Error Amplifier output pin allows connection of an external compensation network. The COMP Pin also can be used as an Error Amplifier shutdown by pulling to ground.
NC	-	2,4,6,13	No Connection.
FB	2	3	Feedback input from desired power supply output; set at 2.5 V with divider network.
I _{SNS}	3	5	Current sense comparitor input.
RT/CT	4	7	Oscillator RC network node.
PGND	5	8	The Power Ground pin separates the high power circuit elements allowing enhanced noise control and decoupling of drive current.

GMT38HC4x

CURRENT MODE PWM CONTROLLERS

FUNCTION	8-PIN PIN NO.	14-PIN PIN NO.	DESCRIPTION
AGND	5	9	The Analog Ground pin isolates all logic and low power analog circuits elements from the power circuit.
OUT	6	10	PWM totem-pole output drive for power switches.
Vd	7	11	Power supply for low power analog and logic functions.
Vdd	7	12	Power output drive stage power connection, allows enhanced decoupling and noise control.
V Ref	8	14	Reference voltage output; must be decoupled with a minimum RC network; do not exceed rated current level.

Table 4: ELECTRICAL SPECIFICATIONS

PARAMETER	TEST CONDITIONS	GMT38HC4x			UNITS
		MIN	TYP	MAX	
Reference Section					
Output Voltage	$T_A=25^{\circ}\text{C}$, $I_o=1.0\text{ mA}$	4.9	5.0	5.10	V
Line Regulation	$12\text{ V} \leq V_{DD} \leq 18\text{ V}$, $I_o=1.0\text{ mA}$, Note 6		2.0	20	mV
Load Regulation	$1.0\text{ mA} < I_o < 20\text{ mA}$		1.0	25	mV
Temperature Stability	Note 1		0.2		mV/ $^{\circ}\text{C}$
Total Output Variation	Line, Load, Temperature, Note 1	4.82	5.0	5.18	mV
Output Noise Voltage	$10\text{ Hz} \leq f \leq 10\text{ kHz}$, $T_A=25^{\circ}\text{C}$, Note 1		150		μV
Unless otherwise stated, these specifications apply for $T_A = -40^{\circ}\text{C}$ to 85°C for GMT38HC4x; $V_{DD}=15\text{ V}$ (Note 4), $R_t=10\text{ K}$, $C_t=3.3\text{ nF}$, $T_A=T_j$, $C_L=0.0$					

GMT38HC4x

CURRENT MODE PWM CONTROLLERS

PARAMETER	TEST CONDITIONS	GMT38HC4x			UNITS
		MIN	TYP	MAX	
Long Term Stability	$T_A=125^{\circ}\text{C}$, 1000 Hours, Note 1		5.0	25	mV
Output Short Circuit		-30	-50	-180	mA
Oscillator Section					
Initial Accuracy	$T_A=25^{\circ}\text{C}$, Note 5	49	52	55	kHz
Temperature Stability	$T_{\min} < T_A < T_{\max}$, Note 1		.04		%/C
Amplitude	RT/CT Peak to Peak		1.7		V
Clock Ramp Reset Current	$V(\text{RT/CT})=2.0\text{ V}$, $T_A=25^{\circ}\text{C}$	7.7		9.0	mA
	$V(\text{RT/CT})=2.0\text{ V}$, Full Temp	7.2	8.0	9.5	mA
Voltage Stability	$12\text{ V} \leq V_{\text{DD}} \leq 18\text{ V}$, Note 6			1.0	%
Unless otherwise stated, these specifications apply for $T_A = -40^{\circ}\text{C}$ to 85°C for GMT38HC4x; $V_{\text{DD}}=15\text{ V}$ (Note 4), $R_t=10\text{ K}$, $C_t=3.3\text{ nF}$, $T_A=T_j$, $C_L=0.0$					

GMT38HC4x

CURRENT MODE PWM CONTROLLERS

PARAMETER	TEST CONDITIONS	GMT38HC4x			UNITS
		MIN	TYP	MAX	
Error Amplifier Section					
Input Voltage	$V_{COMP}=2.5\text{ V}$	2.42	2.5	2.58	V
Input Bias Current	$V_{FB} = 5.0\text{ V}$		-0.02	-1.0	uA
Open Loop Gain	$2.0\text{ V} \leq V_{output} \leq 4.0\text{ V}$	70	80		dB
Unity Gain Bandwidth	Note 1	0.7	1.0		MHz
PSRR	$12\text{ V} \leq V_{DD} \leq 18\text{ V}$	60	80		dB
Output Sink Current	$V_{FB}=2.7\text{ V}, V_{COMP}=1.1\text{ V}$	2.0	10		mA
Output Source Current	$V_{FB}=2.3, V_{COMP}=5$	-0.5	-1.0		mA
Output High Level	$V_{FB}=2.3\text{ V}, R_L=15\text{ K to GND}$	5.0	7.0		V
Output Low Level	$V_{FB}=2.7\text{ V}, R_L=15\text{ K to }V_{REF}$		0.2	1.1	V
Current Sense Amplifier Section					
Amplifier Gain	Notes 2 and 3	2.85	3.0	3.15	V/V
Current Limit Trip Point	$V_{COMP} = 5.0\text{ V}$ Note 2	0.9	1.0	1.1	V
PSRR	$12 \leq V_{DD} \leq 18\text{ V}$, Note 2		70		dB
Input Bias Current		-1.0	0.1	1.0	uA
Delay to Output	$V(CS)=0.0\text{ V to }2.0\text{ V}$		50	100	nS
Unless otherwise stated, these specifications apply for $T_A = -40^\circ\text{C}$ to 85°C for GMT38HC4x; $V_{DD}=15\text{ V}$ (Note 4), $R_t=10\text{ K}$, $C_t=3.3\text{ nF}$, $T_A=T_j$, $C_L=0.0$					

GMT38HC4x

CURRENT MODE PWM CONTROLLERS

PARAMETER	TEST CONDITIONS	GMT38HC4x			UNITS
		MIN	TYP	MAX	
Output Section					
R _{DS(ON)} High R _{DS(ON)} Low	I _{SOURCE} =200 mA I _{SINK} =200 mA		10 5.5		Ohms Ohms
Rise Time	T _A =25°C, C _L =1.0 nF		14	50	nS
Fall Time	T _A =25°C, C _L =1.0 nF		14	40	nS
Pulse Width Modulator					
Max. Duty Cycle at 500 kHz	38HC42/43	90	95		%
	38HC44/45	45	48		%
Min. Duty Cycle	All Devices			0.0	%
Undervoltage Lockout Section					
Start Threshold	38HC42/4	13.5	14.5	15.5	V
	38HC43/5	7.8		9.0	V
UVLO Threshold	38HC42/4	8.0	9.0	10	V
	38HC43/5	7.0	7.6	8.2	V
Start-Up Current	V _{DD} < Start Threshold		50	200	uA
Operating Supply Current			2.6	5.0	mA
Zener Voltage	I _{DD} =25 mA, Note 6		30		
Unless otherwise stated, these specifications apply for T _A = - 40°C to 85°C for GMT38HC4x; V _{DD} =15 V (Note 4), R _t =10 K, C _t =3.3 nF, T _A =T _j , C _L =0.0					

- Notes:
1. These parameters, although guaranteed, are not 100% tested in production.
 2. Parameter measured at trip point of latch with V_{EA}=0.0.
 3. Gain Defined as $A = DV_{PIN1}/V_{TH}(I_{SNS})$; $0.0 \leq V_{TH}(I_{SNS}) \leq 0.8$ V.
 4. Adjust V_{DD} above the Start-Up Threshold before setting at 15 V.
 5. Output frequency equals oscillator frequency for the GMT38HC42/43. Output frequency for the GMT38HC44/45 equals one half the oscillator frequency.
 6. On 8-pin version, 20 V is maximum input on pin 7, as this is also the supply pin for the output stage.

GMT38HC4x

CURRENT MODE PWM CONTROLLERS

Graph 1: Oscillator Frequency Configuration

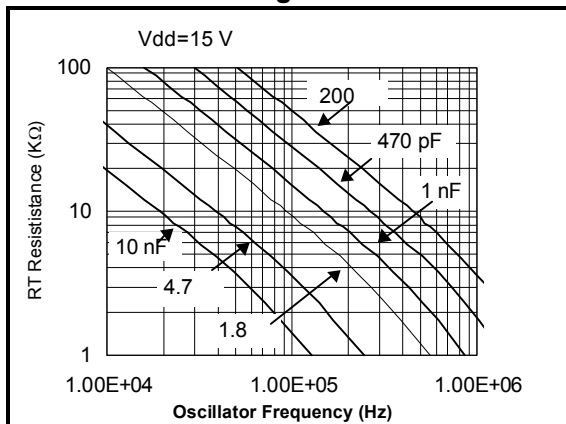

Graph 2: Current Sense Threshold vs. Error Amplifier Output

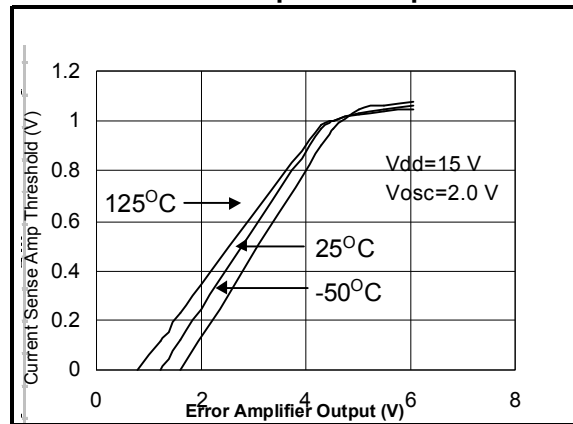

Graph 3: Output Dead Time vs. Oscillator Frequency

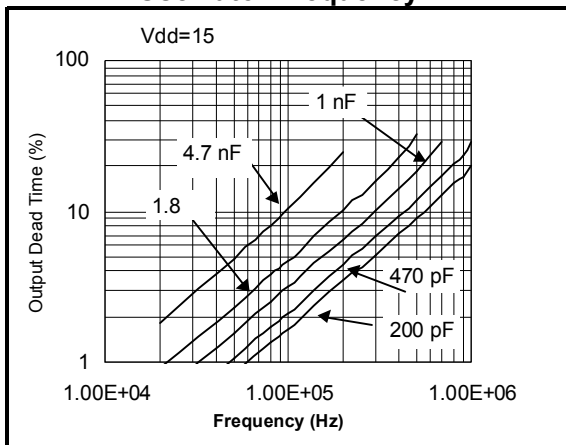

Graph 4: Short-Circuit Reference Current vs. Temperature

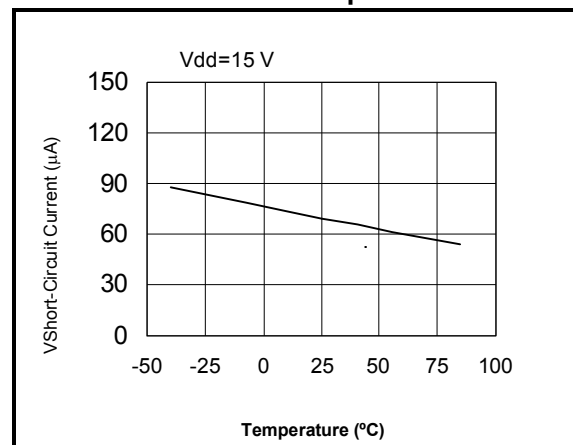

Graph 5: Oscillator Discharge (Current vs. Temperature)

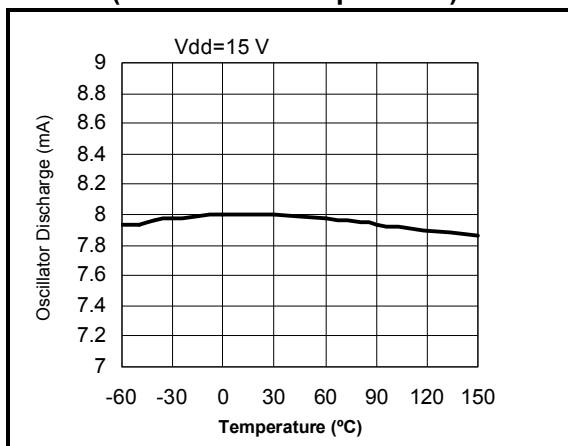

Graph 6: Output Waveform

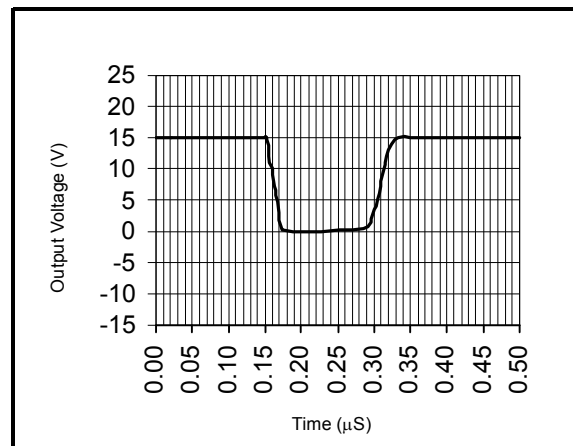

GMT38HC4x

CURRENT MODE PWM CONTROLLERS

APPLICATION INFORMATION

INTRODUCTION

The new GMT38HC42/43/44/45 series of PWM devices from GMT Microelectronics have been designed using BiCMOS Technology, which provides many significant advantages for the switch-mode power supply designer. The BiCMOS technology combines the best of both IC technologies through stable and accurate voltage references that can be created with the bipolar elements while the CMOS devices allow for reduced power consumption and high speed performance. The 38HC4x family members have all been proven to be highly useful “work-horse” types of devices, and are well-suited to many of the popular power supply topologies, including both flyback and buck converter configurations. The GMT38HC4x family of devices are designed to be compatible with industry-standard HC and C drives, while providing the HC level of performance in an MSOP style package.

FAMILY OVERVIEW

The GMT38HC4x family consists of 4 basic devices, differing only in duty cycle range and start-up voltages as described in Table 5.

Table 5: DEVICE SELECTION GUIDE

Duty Cycle	V_{start-up} = 8.4 V V_{min-operate} = 7.6 V	V_{start-up} = 14.5 V V_{min-operate} = 9.0 V
0% to 50% (Approximate)	38HC45 Device	38HC44 Device
0% to 95% (Approximate)	38HC43 Device	38HC42 Device

These various models are offered to solve specific design requirements. The two voltage start-up/operation options allow the designer flexibility in determining when the under voltage lock-out mechanism is operational. Off-line converters, which utilize a boot-strapped design, require a wider hysteresis than DC/DC converters. This is to allow the start-up capacitor to maintain sufficient voltage during the start-up level. DC/DC converters are not burdened with this requirement since the control circuits are supplied directly from the input. Therefore, smaller Hysteresis spreads are offered in the GMT38HC43 and GMT38HC45 devices for DC/DC applications. The GMT38HC42/44 easily accommodate the more popular input voltages while the GMT38HC43/45 are useful for designs operating from lower input voltages.

GMT38HC4x

CURRENT MODE PWM CONTROLLERS

The two duty cycle limit options address the unique requirements of the different power converter topologies. Flyback or Buck-Boost topologies utilize the inductor as an energy storage element. Without some limit on the duty cycle during start-up, the PWM could easily lock into a 100% duty cycle condition and possibly damage the pass device. A maximum of 50% for the duty cycle seems to be optimum for these types of circuits by allowing equal time for the inductor to transfer its stored energy to the load. The GMT38HC44/45 controllers are most suited for these types of applications.

Buck or forward converters topologies do not utilize the inductor as an energy storage element and thus can tolerate duty cycles that exceed 50% so long as provisions are made for resetting the inductor core. An 80% duty cycle is a good practical maximum for forward converters, but they are generally designed to run at 50% maximum duty factor. However, in order to prevent a latched condition during start-up, a 100% duty cycle condition must be permitted. The GMT38HC42/43 controllers are best utilized in these types of topologies.

The duty cycle is limited by the discharge time of the oscillator and may be adjusted by varying the size of the timing capacitor. This makes maximum duty factors on the range of 90% possible.

The high speed of the GMT38HC4x family has been designed with small internal propagation delays, which protect the power switch from overloads and improve the dynamics of the control loop. The result is in improved output voltage regulation.

APPLICATIONS CIRCUIT

In order to demonstrate the capabilities of the GMT38HC4x device family, GMT has developed the following application circuit. The design specifications for this circuit are:

- Converter Technology	Forward
- Operating Frequency	500 kHz
- Output Power	35 Watts
- Input Voltage	18-32 V _{DC}
- Output Voltage/Current	5.0 V _{DC} +/-2% @ 7.0 A _{DC} maximum
- Regulation	+/-1% worst case
- Ripple and Noise	Less than 10 mV p-p
- Efficiency	Greater than 65%
- Operating Temperature	0-70 degrees C

GMT38HC4x

CURRENT MODE PWM CONTROLLERS

APPLICATION SCHEMATIC

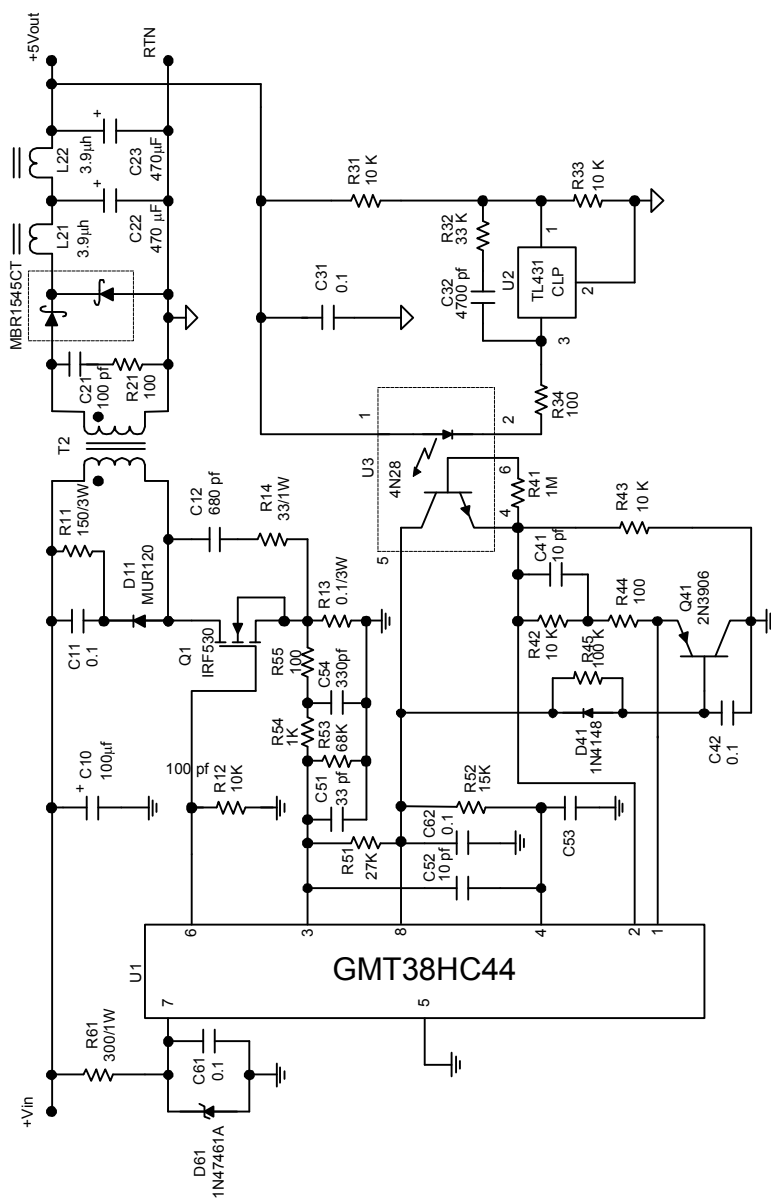

500 kHz Forward Converter

GMT38HC4x

CURRENT MODE PWM CONTROLLERS

CONTROL LOOP CROSS-OVER

The control loop of this design has a relatively high bandwidth of 50 kHz. This provides excellent high speed transient response for critical applications. In cases where a slower loop response is desired, R32 and C32 may be modified as per standard TL431 design practice.

ISOLATION, OPTO-COUPPLERS AND BW EXTENTION

This design has full galvanic isolation between primary and secondary. A 4N28 Opto-isolator is used, but in a special mode which maximizes the BW of the device. First, R41 and R43 both help extend BW by reducing the (significant) phase shift of the part. More significantly, U# directly feeds the summing junction of U1, and the voltage between Collector and Emitter is held fixed at 2.5 volts. Therefore, the normally large CB capacitance of U3 becomes much less dominant, and the BW is thus extended. For convenience, resistor R44 can be used as an injection point for loop stability measurements, using standard Venable style injection transformers, if desired.

OUTPUT DRIVER STAGE

The FET used in this design example is the IRF530, which is rated @ 100 Volts @ 17 Amperes. It has an Rds-on rating of 160 milliohms, and 36-50 nS gate drive response with 1/2 ampere of drive current applied. The typical series gate stabilization resistor is not needed, since the impedance of the MOS output structure will provide stable operation. Additionally, no Schottky clamps are needed at the output due to the MOS channel conduction which provides effective suppression of reverse voltage excursions.

OUTPUT FILTER STAGE

The output filter stage uses a two section LC filter arrangement, which actually behaves as a single pole roll-off stage due to loop dynamics. The control loop makes the first LC section behave in a single-pole fashion due to the current-mode characteristic, while the second LC section contributes an ESR zero, which results in a composite single pole response. The 470 uF output capacitors are rated at ESR levels of approximately 150 milliohms each.

CURRENT SENSE CIRCUITRY

It is important that the current sense resistor R13 has low inductance. Since the resistance is so low, this is typically not a concern and wire "wound" resistors can be effectively used here. A two-pole filter section is used for the current sense input; R54/55 and C51/54 provide increased BW for more precise current control.

GMT38HC4x

CURRENT MODE PWM CONTROLLERS

OSCILLATOR SECTION

As with most PWM devices, there are minimum and maximum suggested values for the RC timing components. In order to maintain current mirror linearity, it is recommended that R52 be no smaller than 1.0 K ohm, and C53 should not be much smaller than 100-200 pF. The values shown will set the oscillator at 1.0 MHz, which results in a 500 kHz output frequency due to the internal flip-flop on the GMT38HC44 device.

GENERAL FEATURES

Transistor Q41 provides a soft-start function, and if desired, its base can be made accessible for an effective shutdown port as well. Diode D61 provides simple and cheap protection against Vcc over-voltage events. The output rectifiers are the popular MBR1545 dual Schottky device, which include two rectifiers in one TO-220 package.

OSCILLATOR DESIGN PROCEDURE

In the design of any switched-mode power converter, one of the most important design decisions that must be made is the selection of the oscillator frequency, and the corresponding RC components. Manufacturers usually provide a design equation which may not always result in the expected oscillator frequency. The reason for this occurrence is that the dependence of oscillator frequency on the external RC components is a complex, non-linear phenomenon. Therefore, the RC design equations will frequently be in error, the magnitude of which can vary depending on the RC values, as well as the desired oscillation frequency. GMT provides two oscillator RC design equations, which are selected by the desired frequency range of oscillation. A listing of various factors is provided which can help guide the selection of the RC values. This information can be used to make a more informed choice of RC components, and minimize the possibility of troublesome drifts and variation in oscillator frequency.

LOW FREQUENCY RC SELECTION

F=100 kHz or less, C = 1000 - 3000 pF range

$$F_{osc} = 1/C \times [205+R/1.8]$$

HIGH FREQUENCY RC SELECTION

F = 400 kHz range, C = 100 pF range

$$F_{osc} = 1/C \times [340+R/1.1]$$

GMT38HC4x

CURRENT MODE PWM CONTROLLERS

RC COMPONENT SELECTION GUIDELINES

The following general guidelines can be used to help select RC values:

- Larger capacitance values (1000 pF and above) will result in more predictable oscillator frequency and dead time values.
- Smaller capacitance values (100-500 pF range) will give the fastest dead time.
- Larger Rt values (2-3K and above) will minimize Vref injected noise.
- Smaller Rt (1K range) values will allow larger Ct values, at the expense of Vref noise.
- Larger Ct (1000 pF and up) values will filter extraneous board noise better.
- Smaller Rt values will minimally increase operational current (2-3 μ A).

Do not use Rt values below 1.0 K ohm; maintain Ct value above 100 pF if possible.

Table 6: APPLICATIONS CIRCUIT PARTS LIST

CAPACITOR	CAPACITANCE	VOLTAGE RATING	COMMENTS
C10	100 μ F	50 V	ALUMINUM ELECTROLYTIC
C1	0.1 μ mF	50 V	CERAMIC
C12	680 pF	100 V	CERAMIC
C21	100 pF	50 V	CERAMIC
C22	470 μ F	10 V	SANYO* 10MV470Gx
C 23	470 μ F	10 V	SANYO* 10MV470Gx
C31	0.1 μ F	50 V	CERAMIC
C42	4700 pF	50 V	CERAMIC XR7 OR BETTER
C41	10 pF	50 V	CERAMIC NPO
C42	0.1 μ F	50 V	CERAMIC
C51	33 pF	50 V	CERAMIC NPO
C52	10 pF	50 V	CERAMIC NPO
C523	100 pF	50 V	CERAMIC NPO
C61	0.1 μ F	50 V	CERAMIC
C62	0.1 μ F	50 V	CERAMIC

GMT38HC4x

CURRENT MODE PWM CONTROLLERS

DIODE	PART NUMBER		COMMENTS
D11	MUR120		MOTOROLA* ULTRA FAST RECOVERY
D21	MBR1545CT		MOTOROLA* DUAL SCHOTTKY DIODE
D41	IN4148		
D61	IN4746A		
INDUCTOR	INDUCTANCE	CURRENT RATING	COMMENTS
L21	3.9 mH	8.0 A	
L22	3.9 mH	8.0 A	
TRANSISTOR	PART NUMBER		COMMENTS
Q1	IR530		
Q41	2N3906		
RESISTOR	VALUE (W)	WATTAGE **	COMMENTS
R11	150	3.0 W	WIRE WOUND
R12	10 K		
R13	0.1	3.0 W	WIRE WOUND
R14	33	1.0 W	
R21	100		
R31	10 K		
R32	33 K		
R33	10 K		
R34	100		
R41	1 MEG		
R42	10 K		
R43	10 K		
R44	100		

GMT38HC4x

CURRENT MODE PWM CONTROLLERS

R45	100 K		
R51	27 K		
R52	15 K		
R53	68 K		
R54	1.0 K		
R55	100		
R611	300	3.0 W	
INTEGRATED CIRCUIT	PART NUMBER		COMMENTS
T1	CUSTOM	SEE TEXT	
U1	GMT38HC44		GMT CURRENT MODE CONTROLLER
U2	TL431CLP		VOLTAGE REGULATOR
U3	4N28		OPTO ISOLATOR
<p>*Philips, Ferroxcube, Motorola, Sanyo, Coitronix, Coilcraft, DAle and Micrometals are registered Trade- names of those companies. **Any watttage not specifically listed is assumed to be 1/8 W or better.</p>			

GMT38HC4x

CURRENT MODE PWM CONTROLLERS

LIFE SUPPORT USAGE POLICY:

GMT's products are not authorized for use as critical components in life support devices or systems without the express written approval of the CEO of GMT. As used herein:

(a) Life support devices or systems are devices or systems which (1) are intended for surgical implant into the body, or (2) support or sustain life, and whose failure to perform when properly used in accordance with instructions for use provided in the labeling, can be reasonably expected to result in a significant injury to the user.

(b) A critical component in any component of a life support device or system whose failure to perform can be reasonably expected to cause the failure of the life support device or system.

GMT Microelectronics Corporation

950 Rittenhouse Road
Norristown, PA 19403

Toll Free: (888) GMT-4771

Ph: (610) 728-9300

Fax: (610) 676-7066

E-Mail: marketing@gmtme.com

Website: www.gmtme.com

Sales Offices

GMT Microelectronics
6 Journey
Suite 230
Aliso Viejo, CA 92656
(949) 425-3756
Fax (949) 425-3767

GMT Microelectronics
17218 Preston Road
Suite 400
Dallas, TX 75287
(972) 735-3155
Fax (972) 735-3156

GMT Microelectronics
14502 North Dale Mabry
Suite 400
Tampa, FL 33618
(813) 908-9544
Fax (813) 908-7683

GMT Microelectronics Singapore
No. 25, #05-02
Woodlands Industrial Park E1
Singapore 757743
(65) 368-6266
Fax (65) 368-6166