

LOC DW	DIST -	REVISIONS			
P	LTR	DESCRIPTION	DATE	DWN	APVD
	A2	REVISED (ECR-11-006020)	23MAR11	JL	WK

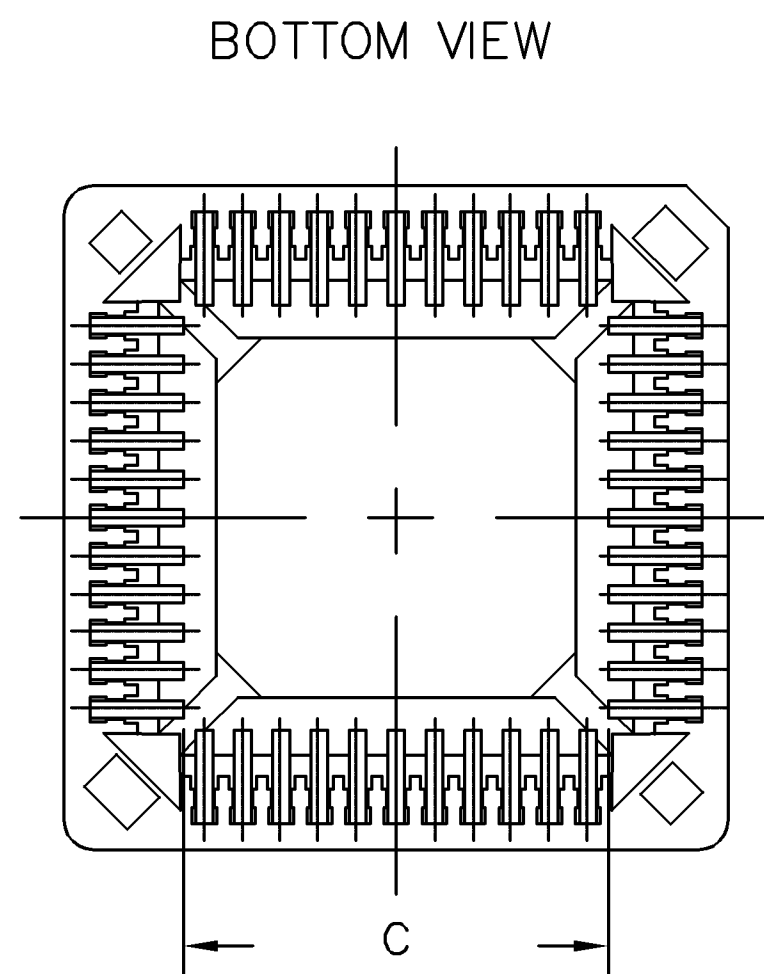

- 1 MATERIAL:  
HOUSING--HIGH TEMPERATURE THERMOPLASTIC, UL94V-0, COLOR: BROWN.  
CONTACT--PHOSPHOR BRONZE.
- 2 CONTACT FINISH: PLATE 0.00254 MIN. MATTE TIN OVER 0.00127 MIN. NICKEL ; ALL OVER.
- 3 PIN #1. TRIANGULAR IDENTIFIER 0.03 MAX RAISED ON FLOOR.
- 4 VIA HOLES NOT RECOMMENDED WITHIN SOCKET SHADOW AREA.
- 5. CURRENT RATING: 1 AMP.
- 6. VOLTAGE RATING: 250V.
- 7. CONTACT RESISTANCE: 20 MILLIOHMS, MAXIMUM.
- 8. INSULATION RESISTANCE: 5,000 MEGOHMS, MINIMUM, INITIAL.
- 9. DIELECTRIC WITHSTANDING VOLTAGE: 600 VAC RMS, MINIMUM.
- 10. OPERATING TEMPERATURE: -55 TO +105 C.
- 11. DURABILITY: 25 CYCLES.
- 12. PLCC DEVICE MUST CONFORM TO JEDEC MS-018 (SQ.) OR MS-016 (RECT.)
- 13. RESISTANCE TO SOLDERING HEAT: 260C MAXIMUM FOR 30 SECONDS MAXIMUM.
- 14 FOR 32 POS: SECTION A-A, E = 11.90  
SECTION B-B, E = 14.45
- 15. EXTRACTION TOOL: 822476-1

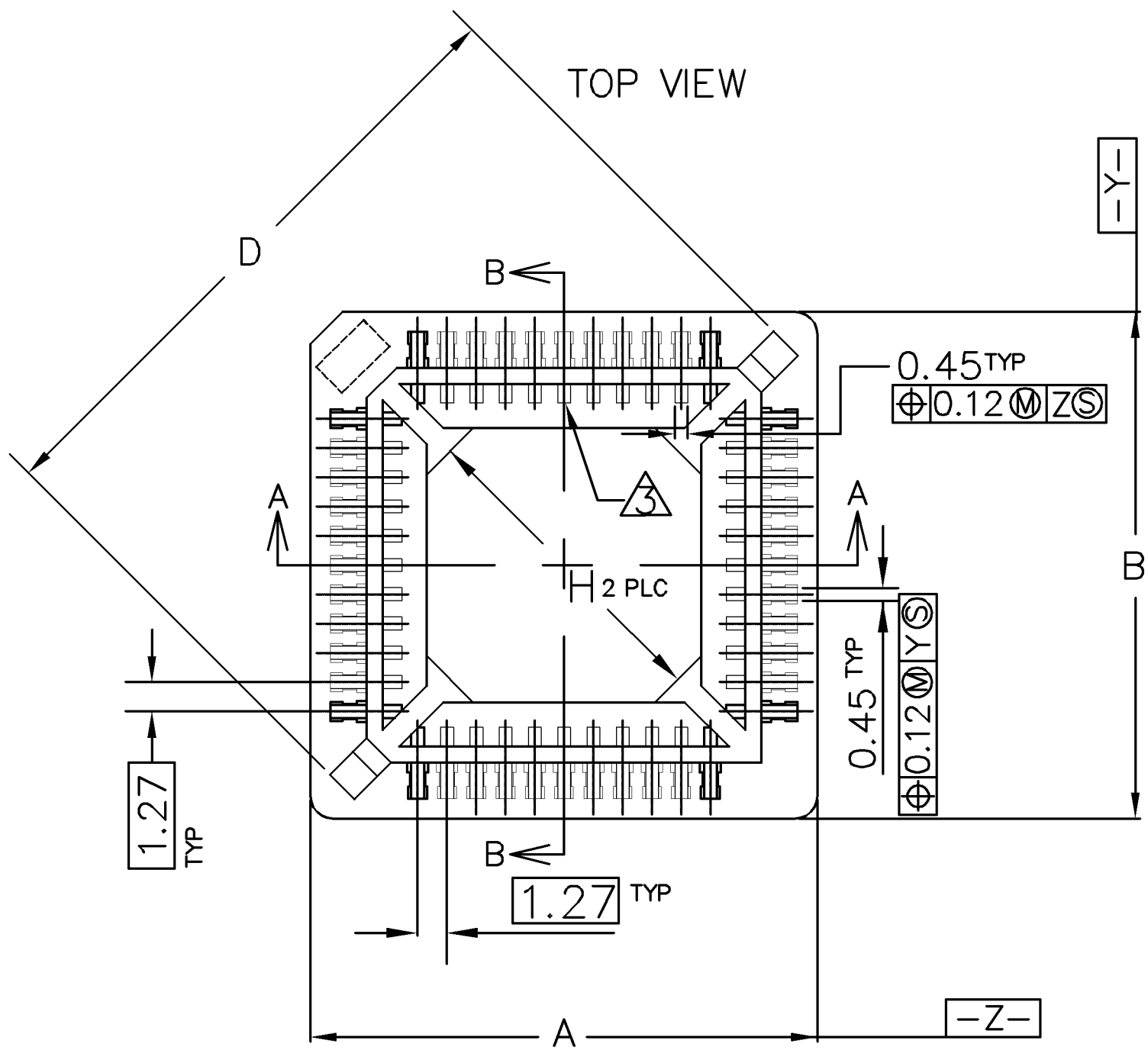
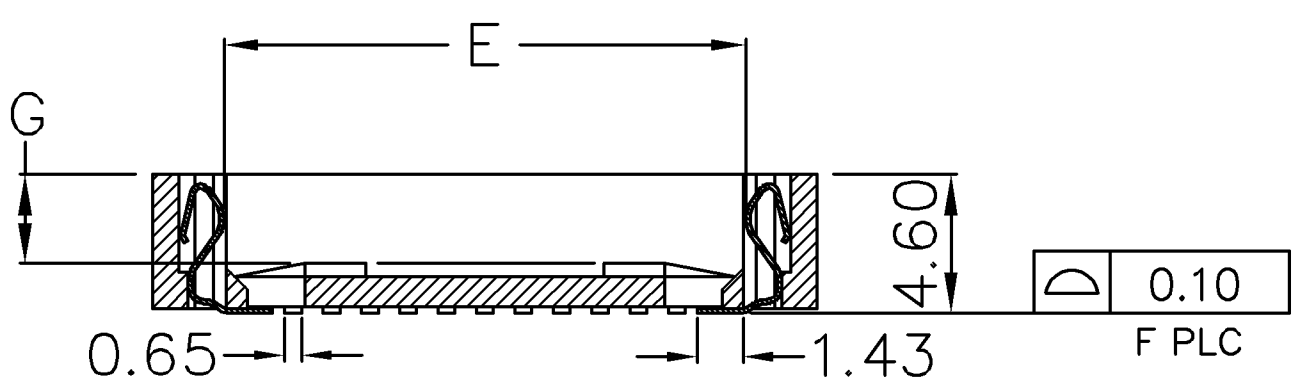

SECTION A-A  
SECTION B-B

44 POSITION SHOWN

H	G	F	E	D	C	B	A	Part Status	Packaging	AMP P/N
8.74	2.60	32	14	21.89	9.25	19.57	16.90	ACTIVE	Tape	3-822516-7
8.74	2.60	32	14	21.89	9.25	19.57	16.90	ACTIVE	Tubes	822516-7
32.14	2.90	84	29.69	45.20	27.03	35.90	35.90	ACTIVE	Tape	3-822516-6
32.14	2.90	84	29.69	45.20	27.03	35.90	35.90	ACTIVE	Tubes	822516-6
24.83	2.90	68	24.61	37.98	21.95	30.82	30.82	ACTIVE	Tape	3-822516-5
24.83	2.90	68	24.61	37.98	21.95	30.82	30.82	ACTIVE	Tubes	822516-5
17.52	2.75	52	19.53	30.78	16.87	25.74	25.74	ACTIVE	Tape	3-822516-4
17.52	2.75	52	19.53	30.78	16.87	25.74	25.74	ACTIVE	Tubes	822516-4
4.04	2.75	20	9.36	16.38	6.71	14.36	14.36	ACTIVE	Tape	3-822516-3
4.04	2.75	20	9.36	16.38	6.71	14.36	14.36	ACTIVE	Tubes	822516-3
7.55	2.75	28	11.90	20.00	9.25	16.90	16.90	ACTIVE	Tape	3-822516-2
7.55	2.75	28	11.90	20.00	9.25	16.90	16.90	ACTIVE	Tubes	822516-2
14.16	2.95	44	16.99	27.20	14.33	22.00	22.00	ACTIVE	Tape	3-822516-1
14.16	2.95	44	16.99	27.20	14.33	22.00	22.00	ACTIVE	Tubes	822516-1

THIS DRAWING IS A CONTROLLED DOCUMENT.

DWN K.KREIDLER 18MAY2001	 <b>TE Connectivity</b>
CHK K.KREIDLER 18MAY2001	
APVD K.KREIDLER 18MAY2001	
NAME	
PRODUCT SPEC 108-57858	PLCC SURFACE MOUNT LEAD FREE VERSION
APPLICATION SPEC	SIZE A300779
WEIGHT -	CAGE CODE C-822516
MATERIAL SEE NOTE	DRAWING NO C-822516
FINISH SEE NOTE	RESTRICTED TO -
CUSTOMER DRAWING	
SCALE -	SHEET 1 OF 2
REV A2	

4

3

2

1

THIS DRAWING IS UNPUBLISHED.

RELEASED FOR PUBLICATION

AUG 2006

© COPYRIGHT 2009

BY TYCO ELECTRONICS CORPORATION.

ALL RIGHTS RESERVED.

LOC  
DWDIST  
/

REVISIONS

P	LTR	DESCRIPTION	DATE	DWN	APVD
		SEE SHEET 1.			

RECOMMENDED PCB FOOTPRINT

84	25.40	25.40	28.80	28.80
68	20.32	20.32	23.72	23.72
52	15.24	15.24	18.64	18.64
44	12.70	12.70	16.10	16.10
32	7.62	10.16	11.02	13.56
28	7.62	7.62	11.02	11.02
20	5.08	5.08	8.48	8.48
NO. OF POSITIONS	J	K	L	M

THIS DRAWING IS A CONTROLLED DOCUMENT.

DIMENSIONS:  
MM

TOLERANCES UNLESS OTHERWISE SPECIFIED:

0 PLC	± -
1 PLC	± -
2 PLC	± -
3 PLC	± -
4 PLC	± -
ANGLES	± -

MATERIAL

FINISH

DWN

CHK

APVD

PRODUCT SPEC

APPLICATION SPEC

WEIGHT

TE Connectivity

NAME

PLCC SURFACE MOUNT  
LEAD FREE VERSION

SIZE

CAGE CODE

DRAWING NO

RESTRICTED TO

A300779

C-822516

CUSTOMER DRAWING

SCALE

SHEET

2 OF 2

REV

A2

AMP 1470-19 REV 31MAR2000