

REV.	ECN NO OR DESCRIPTION	REVISED	DATE
A	INITIAL RELEASE	孫一中	2009.03.17
B	ECN NO:C100288 Modify Coplanarity	LONGJIANG	2010.09.07

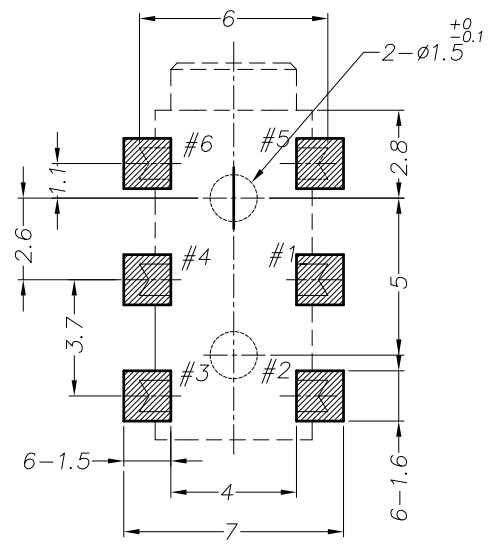

Recommended Pad Layout  
TOP VIEW (TOLERANCE: ±0.05)

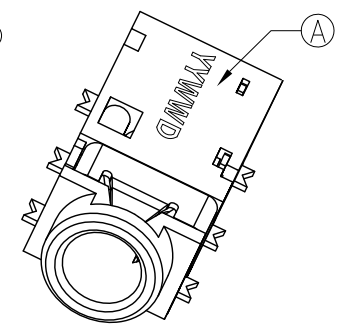
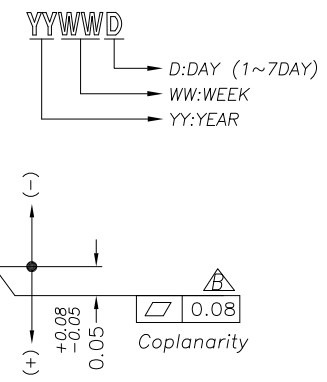
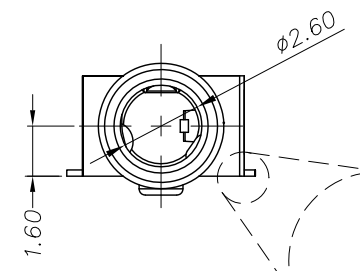
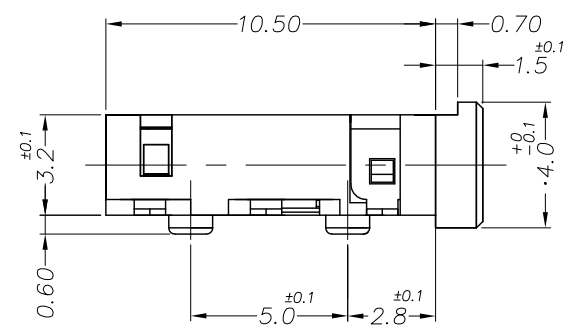
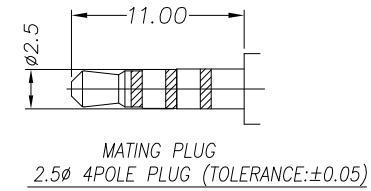
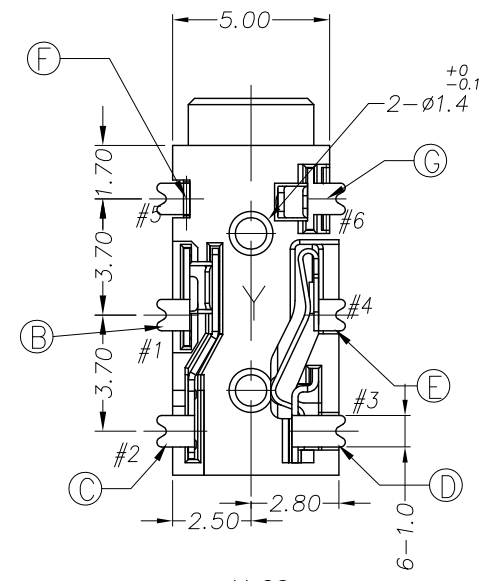
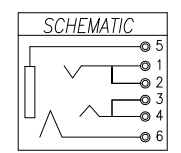

SPECIFICATIONS:

- ELECTRICAL CHARACTERISTICS:
  - RATING: 12V 1A
  - CONTACT RESISTANCE: 30mΩ MAX.(INITIAL)
  - DIELECTRIC WITHSTANDING VOLTAGE: 500V AC FOR ONE MINUTE.
  - INSULATION RESISTANCE: 100MΩ MIN. MEASURED BY 500 VDC
- MECHANICAL CHARACTERISTICS:
  - INSERTION FORCE : 0.3~3.0 KGF
  - WITHDRAWAL FORCE : 0.3~3.0 KGF
- OTHER GENERAL SPEC. TO REFER "2SJ1428 SERIES SPEC".
- TO CONFORM TO SINGATRON HAZARDOUS SUBSTANCE FREE SPEC.
- HALOGEN FREE PRODUCT IDENTIFICATION MARK ON PRODUCT: Ⓞ
- HALOGEN FREE PRODUCT IDENTIFICATION LABEL ON PACKAGING: Ⓞ
- FOR REFLOW SOLDERING LEAD-FREE PROCESS.

NO	DESCRIPTION	QTY	MATERIAL	PLATING & COLOR
G	RING SPRING B	1	PHOSPHOR BRONZE 0.2t	GOLD FLASH
F	EARTH	1	PHOSPHOR BRONZE 0.2t	GOLD FLASH
E	TIP SPRING	1	COPPER ALLOY 0.2t	GOLD FLASH
D	SHUNT TERMINAL-A	1	BRASS 0.2t	GOLD FLASH
C	SHUNT TERMINAL-B	1	PHOSPHOR BRONZE 0.2t	GOLD FLASH
B	RING SPRING A	1	COPPER ALLOY 0.2t	GOLD FLASH
A	HOUSING	1	HIGH TEMP.THERMOPLASTIC	BLACK COLOR

UNLESS OTHERWISE SPECIFIED TOLERANCES		Singatron Enterprise Co., Ltd. 信音企業股份有限公司		
DECIMALS:	ANGLES:	TITLE	2.5φ PHONE JACK	
X : ±0.5	X : ±2°	DWN	PART NO. 2SJ1428-001111	
X.X : ±0.3	X.X : ±1°	CHKD	SCALE 6:1	UNIT: mm
X.XX : ±0.2		APVD	SIZE: A3	SHEET: 10F1
<b>REV: B</b>				
<b>CUSTOMER COPY</b>				