

TO-92L • TO-92LS • MRT

TO-92L is a high power version of TO-92 and TO-92LS is a slimmed TO-92L.

MRT is a 1.2W package power taped transistor designed for use with an automatic placement machine.

Application	Package			V _{CEO} (V) *V _{CES}	I _c (A)	I _c Max. (A)	P _c (W) (T _a =25°C)			h _{FE}	V _{CE} (V)	I _c (mA)	Internal circuit
	TO-92L	TO-92LS	MRT				TO-92L	TO-92LS	MRT				
Low Noise	—	2SA1819	—	-150	-0.05	—	—	0.8	—	120~390	-6	-2	—
	—	2SC4720	—	-150	0.05	—	—	0.8	—	120~390	6	2	—
Driver	2SA934	2SA1818	2SB1329	-32	-1	-2	0.75	0.9	1.2	82~390	-3	-100	—
	2SA935	2SA1902	2SB1330	-80	-0.7	—	0.75	0.9	1.2	82~390	-3	-100	—
	2SB1010	2SB1595	2SB1331	-32	-2	-3	0.75	0.9	1.2	82~390	-3	-500	—
	2SB1041	—	2SB1332	-80	-1	—	0.9	—	1.2	82~390	-3	-100	—
	2SB1043	—	—	-50	-1	—	0.9	—	—	82~390	-3	-100	—
	2SB1212	2SB1596	2SB1328	-160	-1.5	—	0.9	0.9	1.2	56~270	-5	-100	—
	2SB1425	—	—	-20	-2	-3	1.0	—	—	270~1200	-6	-500	—
	—	—	2SB1517	-50	-3	—	—	—	1.2	56~390	-3	-500	—
	2SC2060	2SC4719	2SD2005	32	1	2	0.75	0.9	1.2	82~390	3	100	—
	2SC2061	2SC5061	2SD2006	80	0.7	1	0.75	0.9	1.2	82~390	3	100	—
	2SD1292	—	2SD2008	80	1	2	0.9	—	1.2	82~390	3	500	—
	2SD1384	2SD2450	2SD2007	32	2	2.5	0.75	0.9	1.2	82~390	3	500	—
	2SD1812	2SD2451	2SD2004	160	1.5	—	0.9	0.9	1.2	56~270	5	100	—
	—	—	2SD2146	50	3	—	—	—	1.2	56~390	3	500	—
Low V _{CE(sat)}	—	2SA1903	—	-20	-3	—	—	0.9	—	82~390	-2	-100	—
	2SB1374	2SA1820	—	-50	-2	-5	1.0	0.9	—	82~270	-2	-500	—
	—	2SC5062	—	20	3	—	—	0.9	—	120~560	2	100	—
	2SD2069	2SC4721	—	50	2	5	1.0	0.9	—	82~270	2	500	—
High Voltage Driver	2SA1482	—	—	-150	-0.05	—	0.8	—	—	120~390	-6	-2	—
	2SC3800	—	—	150	0.05	—	0.8	—	—	120~390	6	2	—
Strobo Flash Low V _{CE(sat)}	2SB1306	—	2SB1482	-20	-5	-10	1.2	—	1.2	82~390	-2	-500	—
	2SD1961	—	—	20	5	10	1.2	—	—	120~560	2	500	—
Chroma	2SC3269	2SC4722	2SC4243	300	0.1	—	0.75	0.8	1.0	39~180	10	10	—
High h _{FE}	2SB1425	—	2SB1461	-20	-2	-3	1.0	—	1.2	270~1200	-6	-500	—
	2SD2159	—	—	25	2	3	1.0	—	—	390~2700	6	500	—
High h _{FE} High V _{EBO}	2SD2172	—	—	25	1.2	2	1	—	—	560~2700	5	500	—
Darlington	2SB1256	—	2SB1333	-100	-2	—	1.2	—	1.2	1k~10k	-2	-1000	Fig.1
	—	—	2SB1515	-80	-4	—	—	—	1.2	1k~10k	-3	-2000	Fig.1
	2SD1809	—	2SD2009	60*	1	—	0.9	—	1.2	2k~	3	500	Fig.2
	2SD1929	—	2SD2010	60±10	2	—	1.2	—	1.2	1k~10k	2	1000	Fig.5
	2SD1930	—	2SD2011	100	2	—	1.2	—	1.2	1k~10k	2	1000	Fig.4
	—	—	☆2SC4724	100	3	5	—	—	1.2	2k~10k	2	1500	Fig.4
	2SD1931	—	—	60±10	1.5	—	0.9	—	—	1k~30k	2	1000	Fig.6
	—	—	2SD2308	80	4	—	—	—	1.2	1k~10k	3	2000	Fig.4
—	—	2SD2309	60	4	—	—	—	1.2	1k~10k	3	2000	Fig.3	
Darlington Driver	—	—	2SD2388	90 ⁺²⁰ ₋₁₀	2	3	—	—	1.2	1k~10k	2	1000	Fig.5
High Voltage SW	2SA1584	—	—	-400	-0.1	-0.2	0.9	—	—	56~270	-10	-10	—
	2SA1780	2SA1884	2SA1809	-400	-0.5	-1	0.9	0.9	1.2	56~270	-5	-50	—
	2SA1760	—	—	-400	-0.1	-0.2	0.9	—	—	56~270	-10	-10	—
	—	—	2SA1861	-400	-2	-4	—	—	1.2	56~180	-5	-100	—
	2SC4166	—	—	400	0.1	—	0.9	—	—	56~270	10	10	—

Note: ☆Under development

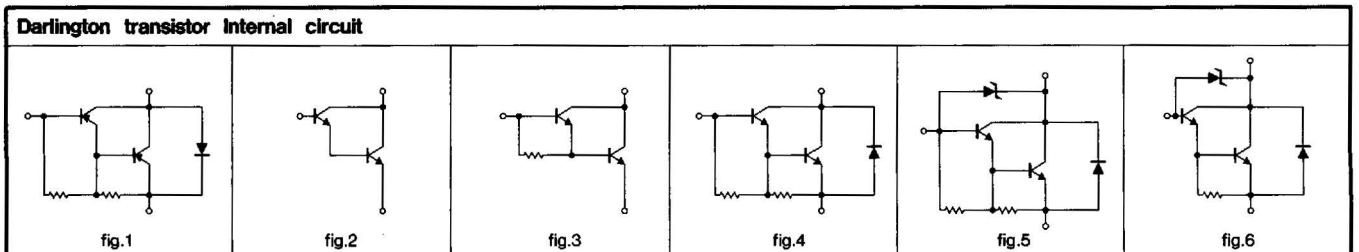

●Product Designation

Specify part No., packaging specification code and h_{FE} ranking code.

Blank unless otherwise required

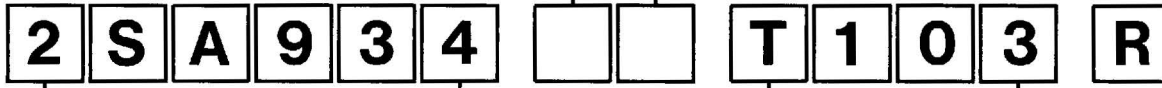

Part No.

Packaging specification code

h_{FE} Ranking code

Code	Package	Package specifications	Quantity /Package (pcs)
T103	TO-92L	Ammo box	2,500
-		Bulk	500
TE4	TO-92LS	Ammo box	3,000
-		Bulk	1,000
T105	MRT	Ammo box	2,000

Code	h_{FE} Range	Code	h_{FE} Range
L	27~56	E	390~820
M	39~82	U	560~1200
N	56~120	V	820~1800
P	82~180	W	1200~2700
Q	120~270	A	1k~
R	180~390	B	5k~
S	270~560	C	10k~

(Unit : mm)

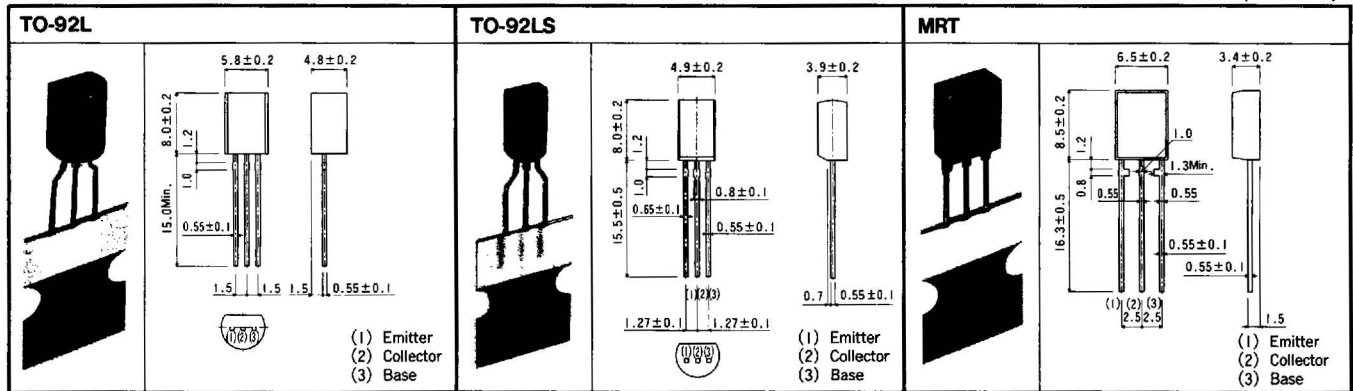

Magazine taping of TO-92L and TO-92LS : lead formed as shown below.

●Packaging Specifications

(Unit : mm)

