

Features

- **Military, Extended and Commercial Temperature Range**
 - -55°C to +125°C Operation (Military)
 - -40°C to +85°C Operation (Extended)
 - 0°C to +70°C Operation (Commercial)
- **End of Write Detection**
 - Ready/Busy Pin
 - Optional \overline{DATA} Polling Feature
- **High Endurance Write Cycles**
 - 10,000 Cycles/Byte Minimum
- **On-Chip Timer**
 - Automatic Byte Erase Before Byte Write
 - 2 ms Byte Write (2864H)
- **5 V ± 10% Power Supply**
- **Power Up/Down Protection Circuitry**
- **200 ns max. Access Time**
- **MIL-STD-883 Class B Compliant**
SMD 5962 Compliant

Description

SEEQ's 2864 is a 5 V only, 8K x 8 NMOS electrically erasable programmable read only memory (EEPROM). It is packaged in most popular thru hole and surface mount

Block Diagram

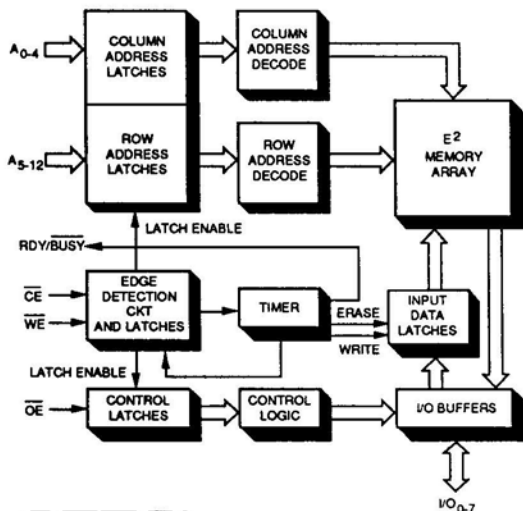

packages and has a ready/busy pin. This EEPROM is ideal for applications which require non-volatility and in-system data modification. The endurance, the number of times which a byte may be written, is a minimum of 10 thousand cycles.

The EEPROM has an internal timer that automatically times out the write time. The on-chip timer, along with the input latches, frees the microcomputer system for other tasks during the write time. The standard byte write cycle time is 10 ms. For systems requiring faster byte write, the 2864H is specified at 2 ms. An automatic byte erase is performed before a byte operation is started. Once a byte has

Pin Configuration

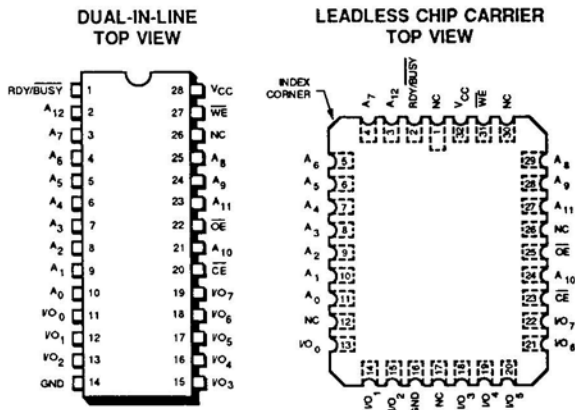

NOTE: The PLCC has the same pin configuration as the LCC except pins 1 and 17 are don't connects.

Pin Names

A_0 - A_4	ADDRESSES — COLUMN (LOWER ORDER BITS)
A_5 - A_{12}	ADDRESSES — ROW
\overline{CE}	CHIP ENABLE
\overline{OE}	OUTPUT ENABLE
\overline{WE}	WRITE ENABLE
I/O_{0-7}	DATA INPUT (WRITE OR ERASE) DATA OUTPUT (READ)
$RDY/BUSY$	DEVICE READY/BUSY
NC	NO CONNECT

been written, the ready/busy pin signals the microprocessor that it is available for another write or a read cycle. All inputs are TTL for both the byte write and read mode. Data retention is specified for ten years.

These two timer EEPROMs are ideal for systems with limited board area. For systems where cost is important, SEEQ has a latch only "52B" family at 16K and 64K bit densities. All "52B" family inputs, except for write enable, are latched by the falling edge of the write enable signal.

Device Operation

There are five operational modes (see Table 1) and, except for the chip erase mode, only TTL inputs are required. To write into a particular location, a 150 ns TTL pulse is applied to the write enable (\overline{WE}) pin of a selected (\overline{CE} low) device. This, combined with output enable (\overline{OE}) being high, initiates a 10 ms/2ms write cycle. During a byte write cycle, addresses are latched on either the falling edge of \overline{CE} or \overline{WE} , whichever one occurred last. Data is latched on the rising edge of \overline{CE} or \overline{WE} , whichever one

occurred first. The byte is automatically erased before data is written. While the write operation is in progress, the RDY/BUSY output is at a TTL low. An internal timer times out the required byte write time and at the end of this time, the device signals the RDY/BUSY pin to a TTL high. The RDY/BUSY pin is an open drain output and a typical 3K pull-up resistor to V_{CC} is required. The pull-up resistor value is dependent on the number of OR-tied RDY/BUSY pins. If RDY/BUSY is not used it can be left unconnected.

Chip Erase

Certain applications may require all bytes to be erased simultaneously. This feature is optional and the timing specifications are available from SEEQ.

\overline{DATA} Polling (Optional Feature)

\overline{DATA} polling is a method of minimizing write times by determining the actual end-point of a write cycle. If a read performed to any address while the device is still writing, it will present the ones-complement of the last byte written. When the device has completed its write cycle, a read from the last address written will result in valid data. Thus, software can simply read from the part until the last data byte written is read correctly.

A \overline{DATA} polling read can occur immediately after a byte is loaded into a page, prior to the initiation of the internal write cycle. \overline{DATA} polling attempted during the middle of a page load cycle will present a ones-complement of the most recent data byte loaded into the page. Timing for a \overline{DATA} polling read is the same as a normal read.

Mode Selection (Table 1)

Mode/Pin	\overline{CE} (20)	\overline{OE} (22)	\overline{WE} (27)	I/O (11-13, 15-19)	RDY/BUSY (1)*
Read	V_{IL}	V_{IL}	V_{IH}	D_{OUT}	High Z
Standby	V_{IH}	X	X	High Z	High Z
Byte Write	V_{IL}	V_{IH}	V_{IL}	D_{IN}	V_{OL}
Write Inhibit	X	V_{IL}	X	High Z/ D_{OUT}	High Z
	X	X	V_{IH}	High Z/ D_{OUT}	High Z

*Pin 1 has an open drain output and requires an external 3K resistor to V_{CC} . The resistor value is dependent on the number of OR-tied RDY/BUSY pins.

Recommended Operating Conditions

		2864/2864H-200	2864/2864H-250	2864/2864H-300
Temperature Range	Commercial	0°C to +70°C	0°C to +70°C	0°C to +70°C
	Extended	-40°C to +85°C	-40°C to +85°C	-40°C to +85°C
	Military	-55°C to +125°C	-55°C to +125°C	-55°C to +125°C
V_{CC} Supply Voltage		5V±10%	5V±10%	5V±10%

Endurance and Data Retention

Symbol	Parameter	Value	Units	Condition
N	Minimum Endurance	10,000	Cycles/Byte	MIL-STD 883 Test Method 1033
T_{DR}	Data Retention	>10	Years	MIL-STD 883 Test Method 1008

NOTE: 1. Characterized. Not tested.

Power Up/Down Considerations

The 2864 has internal circuitry to minimize a false write during system V_{CC} power up or down. This circuitry prevents writing under any one of the following conditions.

- V_{CC} is less than 3 V.¹⁾
- A negative Write Enable (\overline{WE}) transition has not occurred when V_{CC} is between 3 V and 5 V.

Writing will also be prevented if \overline{CE} or \overline{OE} are in TTL logical states other than that specified for a byte write in the Mode Selection table.

**COMMENT: Stresses above those listed under "Absolute Maximum Ratings" may cause permanent damage to the device. This is a stress rating only and functional operation of the device at these or any other conditions above those indicated in the operational sections of this specification is not implied. Exposure to absolute maximum rating conditions for extended periods may affect device reliability.*

Absolute Maximum Stress Ratings*

Temperature

Storage -65°C to +150°C

Under Bias

Military/Extended -65°C to +135°C

Commercial -10°C to +80°C

D.C. Voltage applied to all Inputs or Outputs

with respect to ground +6.0 V to -0.5 V
Undershoot/Overshoot pulse of less than 10 ns

(measured at 50% point) applied to all inputs or outputs with respect to ground (undershoot) -1.0 V (overshoot) + 7.0 V

D.C. Operating Characteristics (Over the operating V_{CC} and temperature range)

Symbol	Parameter	Limits		Units	Test Condition
		Min.	Max.		
I_{CC}	Active V_{CC} Current	Mil./Ext.	120	mA	$\overline{CE} = \overline{OE} = V_{IL}$; All I/O Open; Other Inputs = V_{CC} Max.
		Commercial	110		
I_{SB}	Standby V_{CC} Current	Mil./Ext.	50	mA	$\overline{CE} = V_{IH}$; $\overline{OE} = V_{IL}$; All I/O Open; Other Inputs = V_{CC} Max.
		Commercial	40		
I_{LI}	Input Leakage Current		10	μ A	$V_{IN} = V_{CC}$ Max.
I_{LO}	Output Leakage Current		10	μ A	$V_{OUT} = V_{CC}$ Max.
V_{IL}	Input Low Voltage	-0.1	0.8	V	
V_{IH}	Input High Voltage	2.0	$V_{CC} + 1$	V	
V_{OL}	Output Low Voltage		0.4	V	$I_{OL} = 2.1$ mA
V_{OH}	Output High Voltage	2.4		V	$I_{OH} = -400$ μ A

A.C. Characteristics

Read Operation (Over the operating V_{CC} and temperature range)

Symbol	Parameter	Limits						Units	Test Conditions
		2864H-200 2864-200		2864H-250 2864-250		2864H-300 2864-300			
		Min.	Max.	Min.	Max.	Min.	Max.		
t_{RC}	Read Cycle Time	200		250		300		ns	$\overline{CE} = \overline{OE} = V_{IL}$
t_{CE}	Chip Enable Access Time		200		250		300	ns	$\overline{OE} = V_{IL}$
t_{AA}	Address Access Time		200		250		300	ns	$\overline{CE} = \overline{OE} = V_{IL}$
t_{OE}	Output Enable Access Time		90		90		100	ns	$\overline{CE} = V_{IL}$
t_{DF}	Output Enable High to Output Not being Driven	0	60	0	60	0	60	ns	$\overline{CE} = V_{IL}$
t_{OH}	Output Hold from Address Change, Chip Enable, or Output Enable whichever occurs first	0		0		0		ns	\overline{CE} or $\overline{OE} = V_{IL}$

Read Cycle Timing

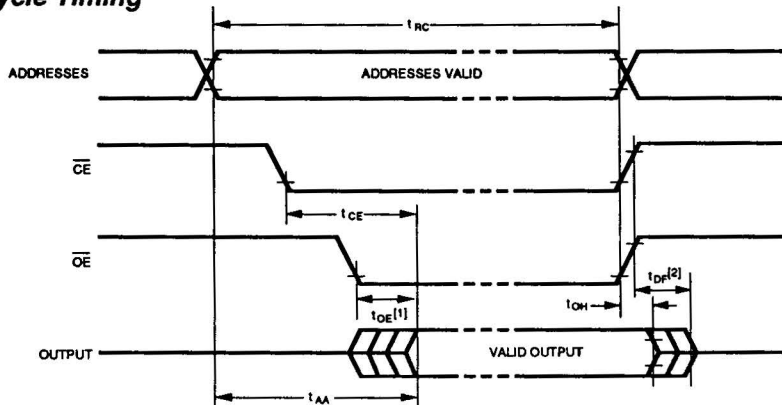

NOTES:

1. \overline{OE} may be delayed to $t_{AA} - t_{CE}$ after the falling edge of \overline{CE} without impact on t_{AA} .
2. t_{DP} is specified from \overline{OE} or \overline{CE} , whichever occurs first.

AC Characteristics

Write Operation (Over the operating V_{CC} and temperature range)

Symbol	Parameter	Limits						Units
		2864H-200 2864-200		2864H-250 2864-250		2864H-300 2864-300		
		Min.	Max.	Min.	Max.	Min.	Max.	
t_{WC}	Write Cycle Time/Byte	2864	10	10	10	10	ms	
		2864H	2	2	2	ms		
t_{AS}	Address to \overline{WE} Set Up Time	10	10	10	ns			
t_{CS}	\overline{CE} to Write Set Up Time	0	0	0	ns			
$t_{WP}^{[2]}$	\overline{WE} Write Pulse Width	150	150	150	ns			
t_{AH}	Address Hold Time	50	50	50	ns			
t_{DS}	Data Set Up Time	50	50	50	ns			
t_{DH}	Data Hold Time	20	20	20	ns			
t_{CH}	\overline{CE} Hold Time	0	0	0	ns			
t_{OES}	\overline{OE} Set Up Time	10	10	10	ns			
t_{OEH}	\overline{OE} Hold Time	10	10	10	ns			
t_{DL}	Data Latch Time	50	50	50	ns			
$t_{DV}^{[3]}$	Data Valid Time	1	1	1	μ s			
t_{DB}	Time to Device Busy	200	200	200	ns			
t_{WR}	Write Recovery Time Before Read Cycle	10	10	10	μ s			

NOTES:

1. This parameter is measured only for the initial qualification and after process or design changes which may affect capacitance.
2. \overline{WE} is noise protected. Less than a 20 ns write pulse will not activate a write cycle.
3. Data must be valid within 1 μ s maximum after the initiation of a write cycle.

Capacitance $T_A^{[1]} = 25^\circ\text{C}, f = 1 \text{ MHz}$

Symbol	Parameter	Max	Conditions
C_{IN}	Input Capacitance	6 pF	$V_{IN} = 0 \text{ V}$
C_{OUT}	Data (I/O) Capacitance	10 pF	$V_{IO} = 0 \text{ V}$

A.C. Test Conditions

Output Load: 1 TTL gate and $C_L = 100 \text{ pF}$

Input Rise and Fall Times: $< 20 \text{ ns}$

Input Pulse Levels: 0.45 V to 2.4 V

Timing Measurement Reference Level:

Inputs 1 V and 2 V

Outputs 0.8 V and 2 V

Write Cycle Timing

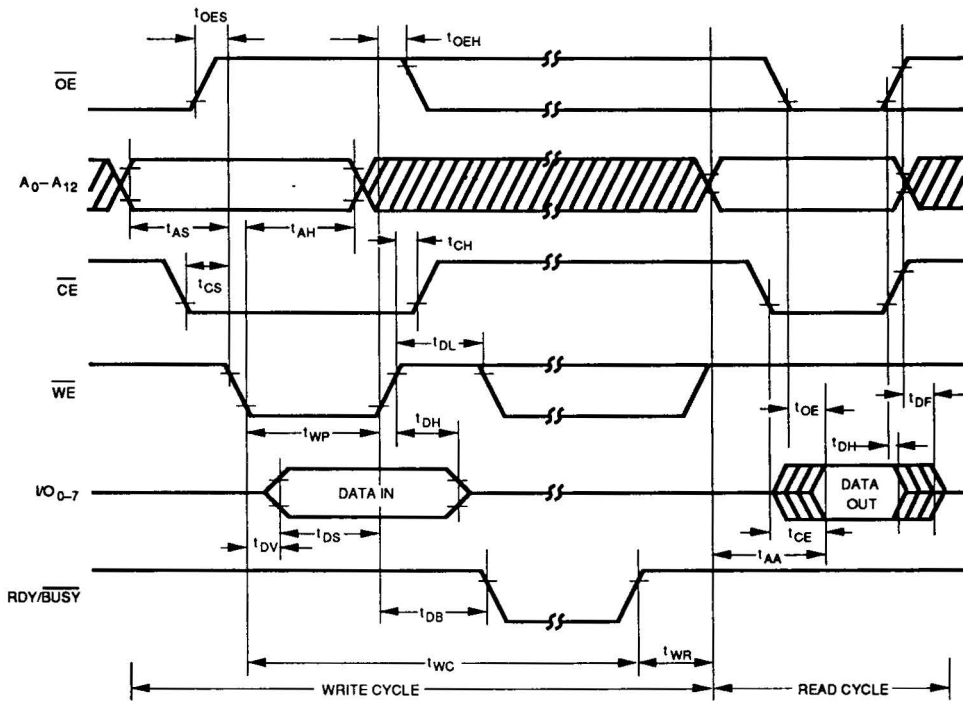

Ordering Information

