

**1N4896  
thru  
1N4915A**

**FEATURES**

- ZENER VOLTAGE 12.8V
- TEMPERATURE COEFFICIENT RANGE: 0.01%/°C to 0.001%/°C
- $N_D$  YIELDS MAXIMUM-RMS NOISE FOR ANY BANDWIDTH

**MAXIMUM RATINGS**

Junction and Storage Temperatures: -65°C to +175°C  
DC Power Dissipation: 400 mW  
Power Derating: 3.20 mW/°C above 50°C

**\* ELECTRICAL CHARACTERISTICS**

@ 25°C, unless otherwise specified

JEDEC TYPE NUMBER	TEST CURRENT $I_{ZT}$	MAX. VOLTAGE CHANGE WITH TEMPERATURE $\Delta V_{ZT}$	TEMPERATURE RANGE	EFFECTIVE TEMPERATURE COEFFICIENT $\alpha_{VZ}$	MAXIMUM DYNAMIC IMPEDANCE $Z_{ZT}$	MAXIMUM NOISE DENSITY $N_D$
	(Note 1 & 5) mA	(Note 2 & 5) VOLTS		(Note 3) $\pm$ %/°C	(Note 4) OHMS	$\mu V/\sqrt{\text{cps}}$
1N4896	0.5	0.096	+25 to +100	0.01	400	0.8
1N4896A	0.5	0.198	-55 to +100	0.01	400	0.8
1N4897	0.5	0.048	+25 to +100	0.005	400	0.8
1N4897A	0.5	0.099	-55 to +100	0.005	400	0.8
1N4898	0.5	0.019	+25 to +100	0.002	400	0.8
1N4898A	0.5	0.040	-55 to +100	0.002	400	0.8
1N4899	0.5	0.010	+25 to +100	0.001	400	0.8
1N4899A	0.5	0.020	-55 to +100	0.001	400	0.8
1N4900	1.0	0.096	+25 to +100	0.01	200	0.4
1N4900A	1.0	0.198	-55 to +100	0.01	200	0.4
1N4901	1.0	0.048	+25 to +100	0.005	200	0.4
1N4901A	1.0	0.099	-55 to +100	0.005	200	0.4
1N4902	1.0	0.019	+25 to +100	0.002	200	0.4
1N4902A	1.0	0.040	-55 to +100	0.002	200	0.4
1N4903	1.0	0.010	+25 to +100	0.001	200	0.4
1N4903A	1.0	0.020	-55 to +100	0.001	200	0.4
1N4904	2.0	0.096	+25 to +100	0.01	100	0.25
1N4904A	2.0	0.198	-55 to +100	0.01	100	0.25
1N4905	2.0	0.048	+25 to +100	0.005	100	0.25
1N4905A	2.0	0.099	-55 to +100	0.005	100	0.25
1N4906	2.0	0.019	+25 to +100	0.002	100	0.25
1N4906A	2.0	0.040	-55 to +100	0.002	100	0.25
1N4907	2.0	0.010	+25 to +100	0.001	100	0.25
1N4907A	2.0	0.020	-55 to +100	0.001	100	0.25
1N4908	4.0	0.096	+25 to +100	0.01	50	0.22
1N4908A	4.0	0.198	-55 to +100	0.01	50	0.22
1N4909	4.0	0.048	+25 to +100	0.005	50	0.22
1N4909A	4.0	0.099	-55 to +100	0.005	50	0.22
1N4910	4.0	0.019	+25 to +100	0.002	50	0.22
1N4910A	4.0	0.040	-55 to +100	0.002	50	0.22
1N4911	4.0	0.010	+25 to +100	0.001	50	0.22
1N4911A	4.0	0.020	-55 to +100	0.001	50	0.22
1N4912	7.5	0.096	+25 to +100	0.01	25	0.20
1N4912A	7.5	0.198	-55 to +100	0.01	25	0.20
1N4913	7.5	0.048	+25 to +100	0.005	25	0.20
1N4913A	7.5	0.099	-55 to +100	0.005	25	0.20
1N4914	7.5	0.019	+25 to +100	0.002	25	0.20
1N4914A	7.5	0.040	-55 to +100	0.002	25	0.20
1N4915	7.5	0.010	+25 to +100	0.001	25	0.20
1N4915A	7.5	0.020	-55 to +100	0.001	25	0.20

\*JEDEC Registered Data.

**12.8 VOLT LOW NOISE  
TEMPERATURE  
COMPENSATED  
ZENER REFERENCE  
DIODES**

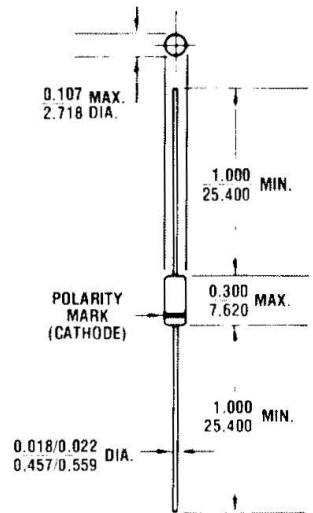

FIGURE 1

All dimensions in INCH  
m.m.

**MECHANICAL CHARACTERISTICS**

CASE: Hermetically sealed glass case. DO-7.

FINISH: All external surfaces are corrosion resistant and leads solderable.

THERMAL RESISTANCE: 300°C/W (Typical) junction to lead at 0.375-inches from body.

POLARITY: Diode to be operated with the banded end positive with respect to the opposite end.

WEIGHT: 0.2 grams.

MOUNTING POSITION: Any.

# 1N4896 thru 1N4915A

**NOTE 1** Nominal voltage for all types is 12.8 Volts  $\pm 5\%$ .

**NOTE 2** Referred to as the 'box' measurement method, the  $\Delta V_{ZT}$  is the maximum voltage variance that will occur as the voltage is scanned thru all temperatures between the temperature range limits.

**NOTE 3** The effective temperature coefficients are tabulated in  $\%/^{\circ}\text{C}$  primarily for information only since temperature compensated diodes inherently have a non-linear voltage-temperature characteristic.

**NOTE 4** The dynamic Zener impedance  $Z_{ZT}$  is derived from the resulting a.c. voltage developed when a 60 cps, rms a.c. current equal to 10% of the D.C. Zener current  $I_{ZT}$  is superimposed on  $I_{ZT}$

**NOTE 5** Voltage measurements to be performed 15 seconds after application of DC current.

**NOTE 6** To specify radiation hardened devices, use "RH" prefix instead of "IN", i.e. RH4896A instead of IN4896A.

**NOTE 7** Consult factory for TX, TXV or JANS equivalent SCDs.

Noise Density ( $N_D$ ) is specified in Microvolts-rms per square root cycle. Actual measurement is performed using a 1 to 3 KHz frequency bandpass at the Zener test current ( $I_{ZT}$ ) @ 25°C ambient temperature.

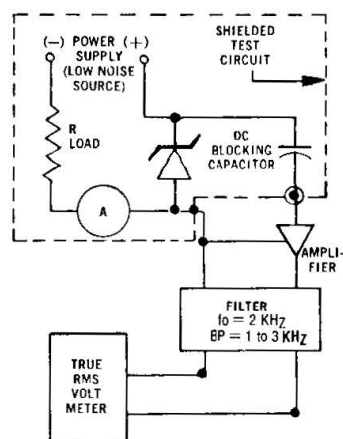

**FIGURE 2** NOISE DENSITY MEASUREMENT CIRCUIT

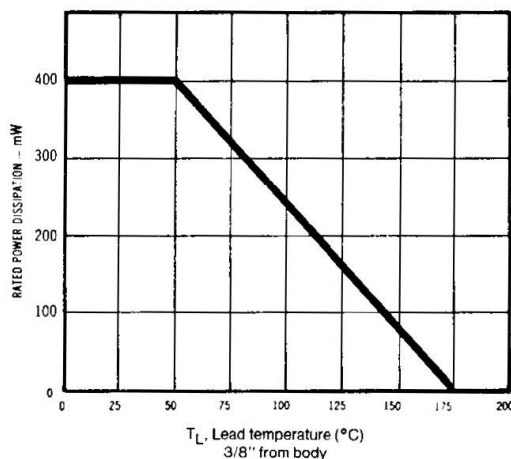

**FIGURE 3** POWER DERATING CURVE