



# Filter Inductors – 1812FS Series



- Magnetically shielded chip inductors
- Provides high performance in transmit and receive filters
- 29 inductance values from 1.0 – 1000  $\mu$ H

**Core material** Ceramic/Ferrite

**Terminations** RoHS compliant silver-palladium-platinum-glass frit. Other terminations available at additional cost.

**Weight** 0.33 – 0.36 g

**Ambient temperature** –40°C to +85°C with I<sub>rms</sub> current, +85°C to +125°C with derated current

**Storage temperature** Component: –40°C to +125°C. Packaging: –40°C to +80°C

**Resistance to soldering heat** Max three 40 second reflows at +260°C, parts cooled to room temperature between cycles

**Temperature Coefficient of Inductance (TCL)** +200 to +700 ppm/°C

**Moisture Sensitivity Level (MSL)** 1 (unlimited floor life at <30°C / 85% relative humidity)

**Failures in Time (FIT) / Mean Time Between Failures (MTBF)**

38 per billion hours / 26,315,789 hours, calculated per Telcordia SR-332

**Packaging** 600/7" reel; 2200/13" reel. Plastic tape: 12 mm wide, 0.25 mm thick, 8 mm pocket spacing, 3.9 mm pocket depth

**PCB washing** Only pure water or alcohol recommended

Part number <sup>1</sup>	L <sup>2</sup> ( $\mu$ H)	% <sup>3</sup> tol	Q <sup>4</sup> min	DCR <sup>5</sup> max (Ohms)	SRF <sup>6</sup> typ (MHz)	Isat <sup>7</sup> (mA)	Irms <sup>8</sup> (mA)
1812FS-102_L_	1.0	<b>10,5</b>	30	0.070	320	3100	2950
1812FS-122_L_	1.2	<b>10,5</b>	35	0.110	280	2800	2600
1812FS-152_L_	1.5	<b>10,5</b>	20	0.105	200	2100	2850
1812FS-222_L_	2.2	<b>10,5</b>	30	0.120	175	1800	2700
1812FS-242_L_	2.4	<b>10,5</b>	25	0.175	160	1900	2050
1812FS-272_L_	2.7	<b>10,5</b>	30	0.200	165	1400	2100
1812FS-332_L_	3.3	<b>10,5</b>	33	0.185	160	1400	1900
1812FS-392_L_	3.9	<b>10,5</b>	32	0.195	145	1300	1700
1812FS-472_L_	4.7	<b>10,5</b>	28	0.15	125	1000	1800
1812FS-562_L_	5.6	<b>10,5</b>	35	0.40	110	1000	1650
1812FS-682_L_	6.8	<b>10,5</b>	35	0.35	110	850	1450
1812FS-103_L_	10	<b>10,5</b>	35	0.55	90	710	1400
1812FS-153_L_	15	<b>10,5</b>	40	0.75	75	680	1150
1812FS-223_L_	22	<b>10,5</b>	45	0.85	15	600	855
1812FS-333_L_	33	<b>10,5</b>	45	1.1	10	540	820
1812FS-393_L_	39	<b>10,5</b>	45	1.1	9.8	500	710
1812FS-473_L_	47	<b>10,5</b>	45	1.2	8.0	390	645
1812FS-683_L_	68	<b>10,5</b>	45	1.8	22.0	260	650
1812FS-104_L_	100	<b>10,5</b>	45	2.5	4.5	260	520
1812FS-154_L_	150	<b>10,5</b>	40	3.8	3.4	220	475
1812FS-224_L_	220	<b>10,5</b>	45	5.4	3.0	180	390
1812FS-274_L_	270	<b>10,5</b>	35	6.5	2.0	150	350
1812FS-334_L_	330	<b>10,5</b>	45	6.8	3.0	150	310
1812FS-394_L_	390	<b>10,5</b>	35	7.6	2.6	140	310
1812FS-474_L_	470	<b>10,5</b>	35	8.7	2.1	130	280
1812FS-564_L_	560	<b>10,5</b>	20	11.2	1.60	110	280
1812FS-684_L_	680	<b>10,5</b>	25	12.7	1.90	100	250
1812FS-824_L_	820	<b>10,5</b>	25	16.8	1.45	90	210
1812FS-105_L_	1000	<b>10,5</b>	30	19.5	1.68	90	160

1. When ordering, specify **tolerance, termination and packaging** codes:

1812FS-105 J L C

**Tolerance:** J = 5% K = 10%

(Table shows stock tolerances in bold.)

**Termination:** L = Silver-palladium-platinum-glass frit terminations  
Special order: T = RoHS tin-silver-copper (95.5/4/0.5)  
or S = non-RoHS tin-lead (63/37).

**Packaging:** C = 7" machine-ready reel. EIA-481 embossed plastic tape (600 parts per full reel).  
B = Less than full reel. On tape, but not machine ready.  
To have a leader and a trailer added (\$25 charge), use code letter C instead.  
D = 13" machine-ready reel. EIA-481 embossed plastic tape (2200 parts per full reel).

- Inductance measured at 100 kHz, 0.1 V<sub>rms</sub>, 0 Adc using a Coilcraft SMD-A fixture in an Agilent/HP 4263B impedance analyzer.
  - Tolerances in bold are stocked for immediate shipment.
  - Q measured at 1 MHz on an Agilent/HP 4291A with an Agilent/HP 16193 test fixture.
  - DCR measured on a micro-ohmmeter and a Coilcraft CCF840 test fixture.
  - SRF measured using an Agilent/HP 8753D network analyzer and a Coilcraft SMD-D test fixture.
  - DC current at which the inductance drops 10% (typ) from its value without current.
  - Current that causes a 40°C temperature rise from 25°C ambient.
  - Electrical specifications at 25°C.
- Refer to Doc 362 "Soldering Surface Mount Components" before soldering.

**Coilcraft**<sup>®</sup>

Specifications subject to change without notice.  
Please check our website for latest information.

Document 254-1 Revised 10/06/08

1102 Silver Lake Road Cary, Illinois 60013 Phone 847/639-6400 Fax 847/639-1469

E-mail [info@coilcraft.com](mailto:info@coilcraft.com) Web <http://www.coilcraft.com>



# Filter Inductors – 1812FS Series

## Typical L vs Frequency

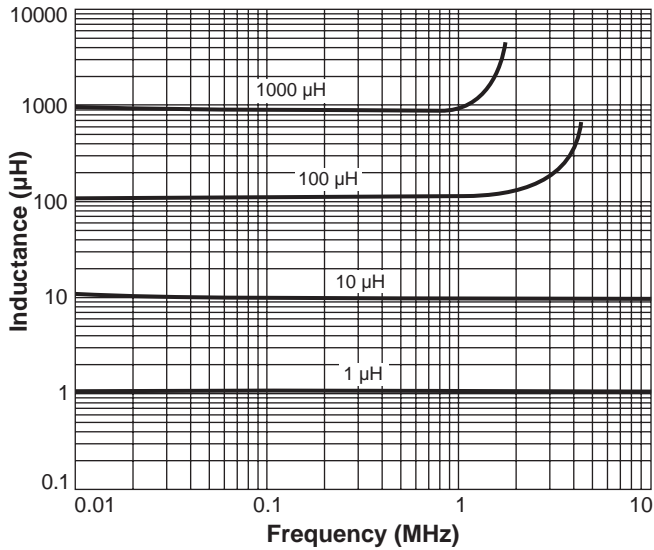

## Typical L vs Current

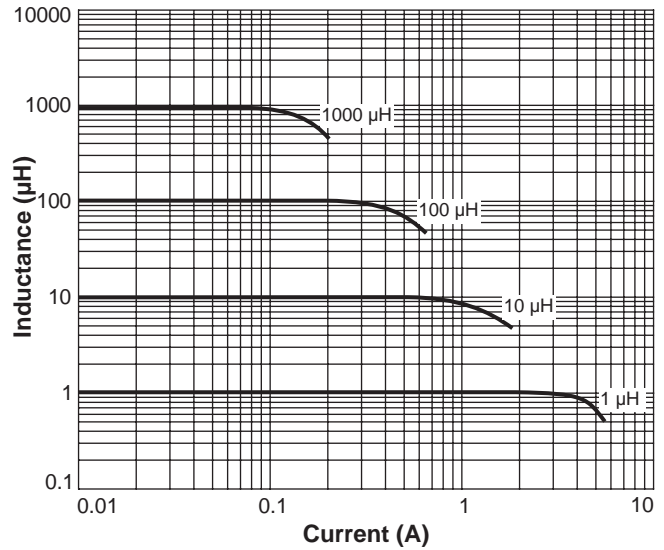

## Irms Derating

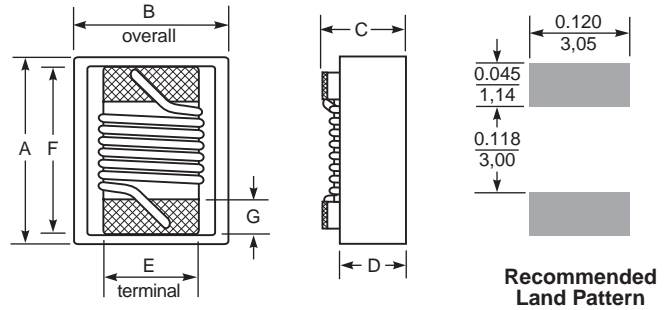
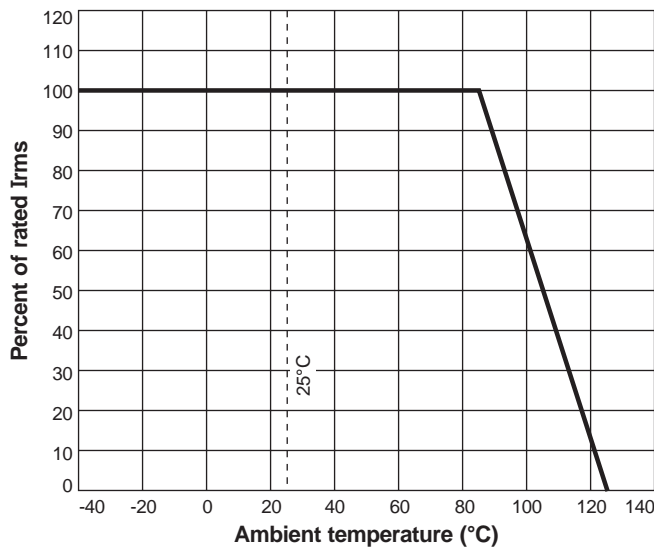

A max	B max	C max	D ref	E ref	F ref	G
0.231	0.196	0.150	0.107	0.100	0.178	0.025 inches
5,87	4,98	3,81	2,72	2,54	4,52	0,64 mm



Specifications subject to change without notice.  
Please check our website for latest information.

Document 254-2 Revised 10/06/08

1102 Silver Lake Road Cary, Illinois 60013 Phone 847/639-6400 Fax 847/639-1469

E-mail info@coilcraft.com Web http://www.coilcraft.com