

## PRODUCT SPECIFICATION

### 1. SCOPE

#### 1.1. Content

This specification covers the performance and test requirements and quality assurance provisions for the AMPMODU\* Mod II (miniature) interconnection system for standard, short-point-of-contact and high pressure designs. The connector is a two piece configuration of which the receptacle may be housed in a flame retardant insulator or mounted directly on a printed circuit board. The plug or post half of the connector may be mounted on an aluminum plate using a nylon bushing as an insulator or inserted into a printed circuit board, or housed in a flame retardant insulator housing.

#### 1.2. Connector Assembly Definition

- A. Board mount receptacle and a .025 x .025 post

#### 1.3. Connector Configuration (Housing and Contact Spacing)

- A. Receptacle contacts used in .100, .125 or .150 contact centers in an insulator housing, which is mounted directly on a printed circuit board.
- B. Receptacle contacts mounted directly on a printed circuit board, .100 centerline minimum.
- C. Post contacts used in .100, .125 or .150 contact centers in an insulator header which is mounted directly on a printed circuit board.
- D. Post contacts mounted directly on a printed circuit board, .100 centerline minimum.
- E. Post contacts used in .100 or .150 contact centers in an insulator bushing which is mounted in aluminum panels.

### 2. APPLICABLE DOCUMENTS

The following documents form a part of this specification to the extent specified herein. In the event of conflict between the requirements of this specification and the product drawing, the product drawing shall take precedence. In the event of conflict between the requirements of this specification and the referenced documents, this specification shall take precedence.

\*Trademark of AMP Incorporated.

© COPYRIGHT 1974, 76, 79 BY AMP INCORPORATED, HARRISBURG, PA. ALL INTERNATIONAL RIGHTS RESERVED. AMP INCORPORATED PRODUCTS COVERED BY U.S. AND FOREIGN PATENTS AND/OR PATENTS PENDING.

				DR C. E. Fritz 9-23-76	<b>AMP</b>   AMP INCORPORATED Harrisburg, Pa.
				CHK R. W. Rohler 9-23-76	
				APP R. Clark 9-23-76	LOC <b>B</b>
	L Revise & Release	<i>FR</i>	<i>2/5</i>		NO <b>A</b>
	per ECN AB-1392		<i>86</i>		REV <b>L</b>
DIST 09	L Add Figure 6			SHEET 1 OF 9	NAME INTERCONNECTION SYSTEM, AMPMODU MOD II
LTR	REVISION RECORD	APP	DATE		

2.1. AMP Specifications

- A. 109 Series: Test Specifications as indicated in Figure 1.
- B. 114-25004: AMPMODU Mod II and IV Female Contact, Application of
- C. 114-25011: Post, AMPMODU Mod I and II, Application of

2.2. Military Standard

MIL-STD-105: Sample Procedures and Tables for Inspection by Attributes

2.3. Military and Federal Specifications

- A. MIL-G-45204: Gold Plating, Electrodeposited
- B. MIL-I-45208: Inspection System Requirements
- C. MIL-M-14: Molding Plastics and Molded Plastic Parts Thermosetting
- D. MIL-M-20693: Molding Plastics, Polyamide
- E. MIL-T-10727: Tin Plating, Electrodeposited
- F. QQ-B-750: Phosphor Bronze
- G. QQ-N-290: Nickel Plating, Electrodeposited

3. PERFORMANCE REQUIREMENTS

The requirements contained herein apply to AMP\* mated parts.

3.1. Ratings

- A. Current: 3 amperes maximum per contact
- B. Temperature: -65°C to 105°C glass filled nylon housing  
 -65°C to 125°C diallyl phthalate housing  
 -55°C to 125°C phenolic housing

*not  
to  
be  
used*

3.2. Test Requirements and Procedure Summary

Test Description	Requirement	Procedure
Examination of Product	Meet requirements of drawing and AMP Spec 114-25004 and 114-25011.	Dimensional and visual.
<b>ELECTRICAL</b>		
Termination Resistance, Dry Circuit (Low Level)	12 milliohms maximum for ph brz; 20 milliohms maximum for Cu-Ni-Sn.	50 mv maximum open circuit, 100 ma maximum short circuit; AMP Spec 109-6, cond A, measured as indicated in Figure 3 or 4.

Figure 1 (cont)

<b>AMP</b>		AMP INCORPORATED Harrisburg, Pa.	<b>SHEET</b> <u>2</u> OF <u>9</u>	
LOC <b>B</b>	<b>A</b>	NO <b>108-9007</b>	REV <b>L</b>	
NAME INTERCONNECTION SYSTEM, AMPMODU MOD II				

Test Description	Requirement	Procedure																
Termination Resistance, Rated Current	12 milliohms maximum for ph brz ; 20 milliohms maximum for Cu-Ni-Sn .	AMP Spec 109-25, current as indicated but not to exceed 3 amperes, measured as indicated in Figure 3 or 4.																
Insulation Resistance	5000 megohms minimum initial; 1000 megohms minimum after moisture.	Unmated connectors, test between adjacent contacts and contacts to mounting hardware, 500 vdc; AMP Spec 109-28.																
Dielectric Withstanding Voltage	Test Voltage(rms) Altitude, <table border="1" style="margin-left: auto; margin-right: auto;"> <tr> <td>.100Cl</td> <td>.125Cl</td> <td>.150Cl</td> <td>feet</td> </tr> <tr> <td>750</td> <td>1000</td> <td>Sea Level</td> <td></td> </tr> <tr> <td>300</td> <td>400</td> <td>50,000</td> <td></td> </tr> <tr> <td>275</td> <td>275</td> <td>70,000</td> <td></td> </tr> </table> No breakdown or flashover.	.100Cl	.125Cl	.150Cl	feet	750	1000	Sea Level		300	400	50,000		275	275	70,000		Unmated connectors, test between adjacent contacts and contacts to mounting hardware, 500 volts per second until test potential is reached; hold for 1 minute; AMP Spec 109-29-1.
.100Cl	.125Cl	.150Cl	feet															
750	1000	Sea Level																
300	400	50,000																
275	275	70,000																

**MECHANICAL**

Connector Mating Force	Maximum force per contact. <table border="1" style="margin-left: auto; margin-right: auto;"> <tr> <td>Type</td> <td>Ounces</td> </tr> <tr> <td>Standard</td> <td>6</td> </tr> <tr> <td>Short-point-of-contact</td> <td>6</td> </tr> <tr> <td>High pressure</td> <td>20</td> </tr> </table>	Type	Ounces	Standard	6	Short-point-of-contact	6	High pressure	20	Connector mating force divided by number of contacts; AMP Spec 109-42, cond A, measure force after third mating.
Type	Ounces									
Standard	6									
Short-point-of-contact	6									
High pressure	20									
Connector Unmating Force	Minimum force per contact. <table border="1" style="margin-left: auto; margin-right: auto;"> <tr> <td>Type</td> <td>Ounces</td> </tr> <tr> <td>Standard</td> <td>.75</td> </tr> <tr> <td>Short-point-of-contact</td> <td>1.00</td> </tr> <tr> <td>High pressure</td> <td>3.00</td> </tr> </table>	Type	Ounces	Standard	.75	Short-point-of-contact	1.00	High pressure	3.00	Connector unmating force divided by number of contacts; AMP Spec 109-42, cond A, mate connector and measure force to unmate.
Type	Ounces									
Standard	.75									
Short-point-of-contact	1.00									
High pressure	3.00									
Contact Engaging Force	Maximum force per contact. <table border="1" style="margin-left: auto; margin-right: auto;"> <tr> <td>Type</td> <td>Ounces</td> </tr> <tr> <td>Standard</td> <td>6</td> </tr> <tr> <td>Short-point-of-contact</td> <td>6</td> </tr> <tr> <td>High pressure</td> <td>20</td> </tr> </table>	Type	Ounces	Standard	6	Short-point-of-contact	6	High pressure	20	Measure force to engage after sizing 3 times using gage 1, as indicated in Figure 6; AMP Spec 109-35, engagement depth .205 ± .010.
Type	Ounces									
Standard	6									
Short-point-of-contact	6									
High pressure	20									
Contact Separating Force	Minimum force per contact. <table border="1" style="margin-left: auto; margin-right: auto;"> <tr> <td>Type</td> <td>Ounces</td> </tr> <tr> <td>Standard</td> <td>.75</td> </tr> <tr> <td>Short-point-of-contact</td> <td>1.00</td> </tr> <tr> <td>High pressure</td> <td>3.00</td> </tr> </table>	Type	Ounces	Standard	.75	Short-point-of-contact	1.00	High pressure	3.00	Size 3 times using gage 1, as indicated in Figure 6; insert gage 2 and measure force to separate; AMP Spec 109-35, separation depth .205 ± .010.
Type	Ounces									
Standard	.75									
Short-point-of-contact	1.00									
High pressure	3.00									

Figure 1 (cont)

**SHEET**

3 OF 9

**AMP**

**AMP INCORPORATED**  
Harrisburg, Pa.

LOC

**B**

NO

**A**

**108-9007**

REV

**L**

NAME

INTERCONNECTION SYSTEM,  
AMP MODU MOD II

Test Description	Requirement	Procedure																														
Durability	Termination resistance, dry circuit; individual contact separation force; no mechanical damage.	Mate and unmate at a rate of 150 cycles per hour for the number of cycles specified; AMP Spec 109-27. <table border="1"> <thead> <tr> <th>Type</th> <th>Plating</th> <th>Cycles</th> </tr> </thead> <tbody> <tr> <td>Std</td> <td>30 <math>\mu</math>in. gold</td> <td>225</td> </tr> <tr> <td>Std</td> <td>15 <math>\mu</math>in. gold</td> <td>100</td> </tr> <tr> <td>Std</td> <td>Tin</td> <td>100</td> </tr> <tr> <td>Short-</td> <td>30 <math>\mu</math>in. gold</td> <td>200</td> </tr> <tr> <td>point-of-</td> <td>15 <math>\mu</math>in. gold</td> <td>75</td> </tr> <tr> <td>contact</td> <td>Tin</td> <td>75</td> </tr> <tr> <td>Hi/press</td> <td>30 <math>\mu</math>in. gold</td> <td>50</td> </tr> <tr> <td>Hi/press</td> <td>15 <math>\mu</math>in. gold</td> <td>25</td> </tr> <tr> <td>Hi/press</td> <td>Tin</td> <td>25</td> </tr> </tbody> </table>	Type	Plating	Cycles	Std	30 $\mu$ in. gold	225	Std	15 $\mu$ in. gold	100	Std	Tin	100	Short-	30 $\mu$ in. gold	200	point-of-	15 $\mu$ in. gold	75	contact	Tin	75	Hi/press	30 $\mu$ in. gold	50	Hi/press	15 $\mu$ in. gold	25	Hi/press	Tin	25
Type	Plating	Cycles																														
Std	30 $\mu$ in. gold	225																														
Std	15 $\mu$ in. gold	100																														
Std	Tin	100																														
Short-	30 $\mu$ in. gold	200																														
point-of-	15 $\mu$ in. gold	75																														
contact	Tin	75																														
Hi/press	30 $\mu$ in. gold	50																														
Hi/press	15 $\mu$ in. gold	25																														
Hi/press	Tin	25																														
Vibration	No interruption of continuity greater than 1 microsecond; no physical damage.	Subject wired and mated connectors to 20 G's, 10-2000 Hz, with 100 ma current applied; AMP Spec 109-21, cond E.																														
Physical Shock	No interruption of continuity greater than 1 microsecond; no physical damage.	Subject rigid mount wired and mated connectors to 100 G's, 6 millisecond; sawtooth wave form; with 100 ma current applied; 3 drops, 3 each direction per plane total 18 shocks; AMP Spec 109-26, cond I.																														
Post Retention	Post shall not dislodge from its normal position. No physical damage.	Apply an axial load of 9 pounds (3 pounds for headers) to each post; AMP Spec 109-30.																														
Solderability	Solderable areas of the contact shall have a solder coverage of 95% minimum.	AMP Spec 109-11-1, except copper-nickel-tin alloy 725 per 109-11-2.																														

**ENVIRONMENTAL**

Thermal Shock	Termination resistance, dry circuit; no physical damage.	Subject wired and mated connector to 5 cycles, temperature see Para 3.1. B.; AMP Spec 109-22.
---------------	--	---

<b>AMP</b>		AMP INCORPORATED Harrisburg, Pa.		SHEET 4 OF 9	
LOC B	A	NO 108-9007	REV L		
NAME INTERCONNECTION SYSTEM, AMP MODU MOD II					

Figure 1 (cont)

Test Description	Requirement	Procedure
Moisture Resistance	Termination resistance, dry circuit; insulation resistance; dielectric withstanding voltage; no physical damage.	Subject mated connectors to 10 days temperature-humidity cycling, 25° to 65°C, 80-98 RH, 5 cold shocks at -10°C; AMP Spec 109-23, cond B, method III, less step 7b.
Corrosion, Salt Spray	Termination resistance, dry circuit and rated current.	Subject mated connectors to 5% solution, 48 hours; AMP Spec 109-24, cond B.
Corrosion, Industrial Gas	Termination resistance, dry circuit and rated current.	Subject mated connectors to 10% SO <sub>2</sub> environment, 24 hours; AMP Spec 109-37, method 1.

Figure 1 (end)

SHEET <u>5</u> OF <u>9</u>	<b>AMP</b>   AMP INCORPORATED Harrisburg, Pa.		
LOC <b>B</b>	NO <b>A</b>	108-9007	REV <b>L</b>
NAME INTERCONNECTION SYSTEM, AMP MODU MOD II			

### 3.3. Connector Tests and Sequence

Test or Examination	MIL-STD-202 Reference		Test Group (a)		
			1, 2, 3 (a)	4 Evaluation	5 Post and Headers
	Method	Cond	Test Sequence (b)		
Examination of Product (d)			1	1	1
Termination Resistance, Dry Circuit			5, 11, 14, 18, 22, 25		
Termination Resistance, Rated Current	307		6, 23, 26		
Insulation Resistance	302	B	8, 19		2, 8
Dielectric Withstanding Voltage	301		9, 20		3, 9
Connector Mating Force			4		
Connector Unmating Force			7		
Contact Engaging Force			2		
Contact Separating Force			3, 13		
Durability			12		
Vibration	204	D	15		5
Physical Shock	213	I	16		6
Post Retention					10
Solderability				2	
Thermal Shock	107		10		4
Moisture Resistance	106	B	17		7
Corrosion, Salt Spray	101	B	21		
Corrosion, Industrial Gas (c)			24		

(a) Test group 1 standard, group 2 short-point and group 3 high pressure shall consist of a minimum of 6 connector assemblies (with a minimum of 36 post-receptacle pairs) of each plating configuration indicated in Figure 5. Test group 4 shall consist of a minimum of 30 each receptacle and post of each type plating indicated in Figure 5. Test group 5 shall consist of 6 headers with a minimum of 36 posts of each type plating indicated in Figure 5. All test measurements shall consist of a minimum of 30 random readings from each group.

(b) Numbers indicate sequence in which tests are performed.

(c) Test applicable to post tin plated high pressure contacts and all gold plated contacts.

(d) All tin parts shall be lubricated prior to testing.

Figure 2

<b>AMP</b>		AMP INCORPORATED Harrisburg, Pa.		SHEET 6 OF 9	
LOC B	A	NO 108-9007	REV L		
NAME INTERCONNECTION SYSTEM, AMP MODU MOD II					

#### 4. PRODUCT ASSURANCE PROVISIONS

##### 4.1. General Requirements

Connectors presented under this specification shall be a product which has passed qualification tests per Para 4.2. and which meet the quality assurance requirements of Para 4.3.

##### 4.2. Qualification Requirements

Qualification requirements shall be in accordance with the test sequence of Figure 2 of this specification.

##### 4.3. Quality Assurance Requirements

Product manufacture shall be controlled by an inspection system at least equivalent to the requirements of MIL-I-45208 to assure the delivered product to be within 1.0 AQL when inspected in accordance with MIL-STD-105, Normal Sampling, Inspection Level II.

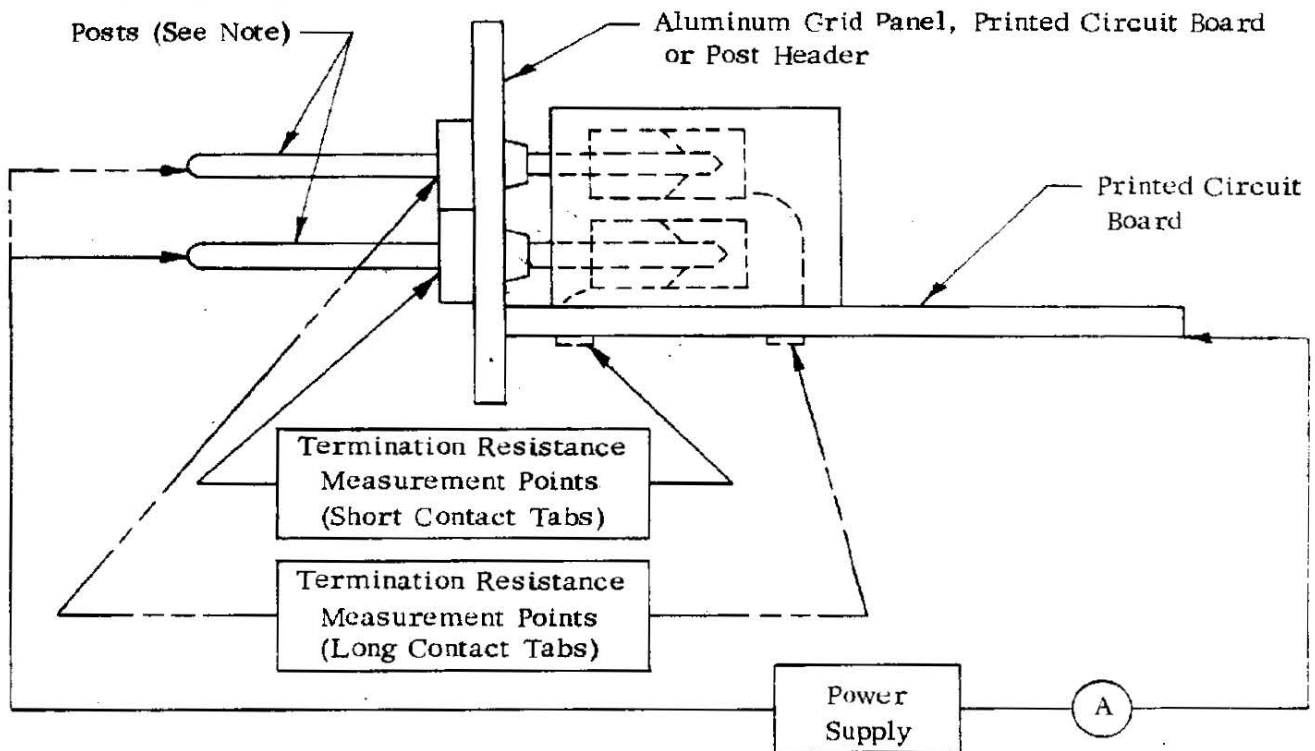

Note: Post plating shall be identical to receptacle plating when conducting tests, see Figure 5.

Figure 3  
Termination Resistance Measurement Points for Post Header  
Assembly and Connector

SHEET 7 OF 9	<b>AMP</b>		AMP INCORPORATED Harrisburg, Pa.	
	LOC B	A	NO 108-9007	REV L
NAME INTERCONNECTION SYSTEM, AMP MODU MOD II				

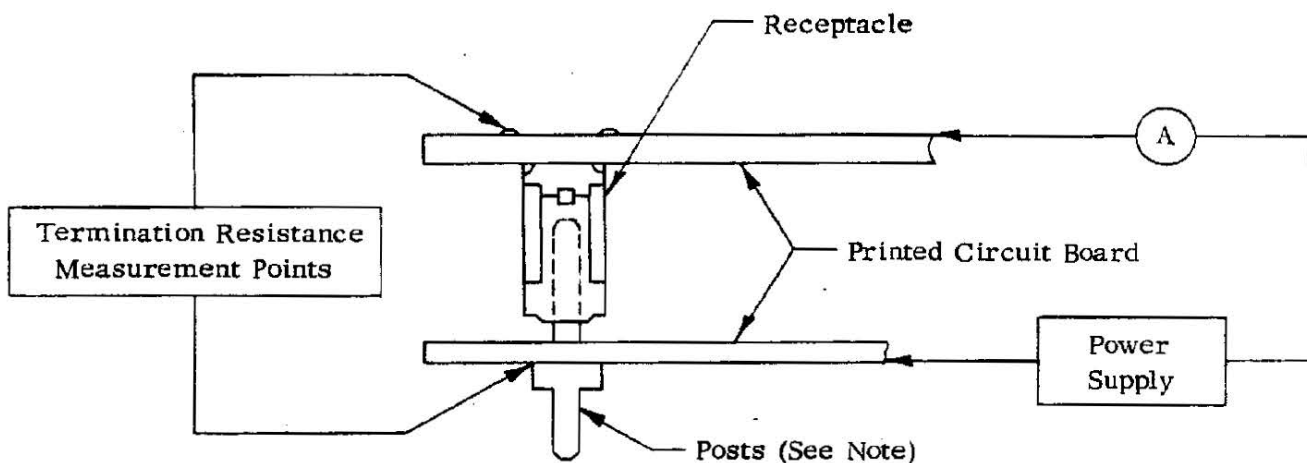

Note: Post plating shall be identical to receptacle plating when conducting tests, see Figure 5.

Figure 4

Termination Resistance Measurement Points for Printed Circuit Board Mounted Receptacles

Test Group	Plating Configuration (Thickness in Microinches)	
	Receptacle	Post
1A	30 Au/50 Ni	30 Au/50 Ni
1B	15 Au/50 Ni	15 Au/50 Ni
1C	Pre Tin	100 Sn/50 Ni
2A	30 Au Select/50 Ni	30 Au/50 Ni
2B	15 Au/50 Ni	15 Au/50 Ni
2C	100 Sn/50 Ni	100 Sn/50 Ni
3A	30 Au Select/50 Ni	30 Au/50 Ni
3B	15 Au/50 Ni	15 Au/50 Ni
3C	Pre Tin	100 Sn/50 Ni
4A	30 Au/50 Ni	30 Au/50 Ni
4B	30 Au Select/50 Ni	30 Au/50 Ni
4C	15 Au/50 Ni	15 Au/50 Ni
4D	Pre Tin	100 Sn/50 Ni
4E	100 Sn/50 Ni	100 Sn/50 Ni
5A	Stake-to-board post and post headers only	30 Au/50 Ni
5B		15 Au/50 Ni
5C		100 Sn/50 Ni

Figure 5  
Plating Configuration

<b>AMP</b>		AMP INCORPORATED Harrisburg, Pa.		<b>SHEET</b>	
				8 OF 9	
LOC B	NO A	108-9007		REV L	
NAME INTERCONNECTION SYSTEM, AMP MODU MOD II					



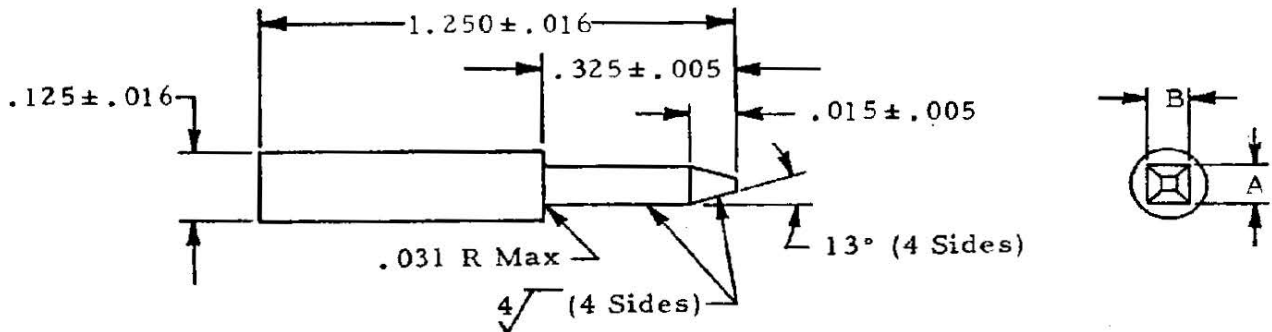

Notes:

1. Tolerance:  $\pm .005$  or  $\pm 2^\circ$  as applicable, unless otherwise specified.
2. Material: Tool steel, AISI type 02 per AMP Specification 100-15.
3. Heat treat: Rockwell C 50-55.
4. Gage surface shall be clean of contaminants or lubricants.

Gage	A	B
1	$.0260 \begin{matrix} +.0000 \\ -.0001 \end{matrix}$	$.0260 \begin{matrix} +.0000 \\ -.0001 \end{matrix}$
2	$.0240 \begin{matrix} +.0001 \\ -.0000 \end{matrix}$	$.0240 \begin{matrix} +.0001 \\ -.0000 \end{matrix}$

Figure 6  
Force Gages

SHEET <u>9</u> OF <u>9</u>	<b>AMP</b>		AMP INCORPORATED Harrisburg, Pa.	
	LOC <b>B</b>	NO <b>A</b>	<b>108-9007</b>	REV <b>L</b>
NAME INTERCONNECTION SYSTEM, AMP MODU MOD II				