



**NEW:**  
White coating for  
LED applications

### Characteristics

- Magnetically shielded version which results in a low leakage field
- High storage capacity
- Low self-losses
- Highest possible current loading for SMD Inductors
- Operating temperature:  $-40\text{ }^{\circ}\text{C}$  to  $+125\text{ }^{\circ}\text{C}$

### Applications

- Switching regulators with low operating voltages (computer, laptop, mobile phones, pagers)
- Integrated DC/DC-converter
- Perfectly suitable for switching regulators with extremely high efficiency ( $> 86\%$ )
- Graphic cards
- Plastic base: Because of the one piece construction these are more suitable for high vibration or shock applications

QR-Code

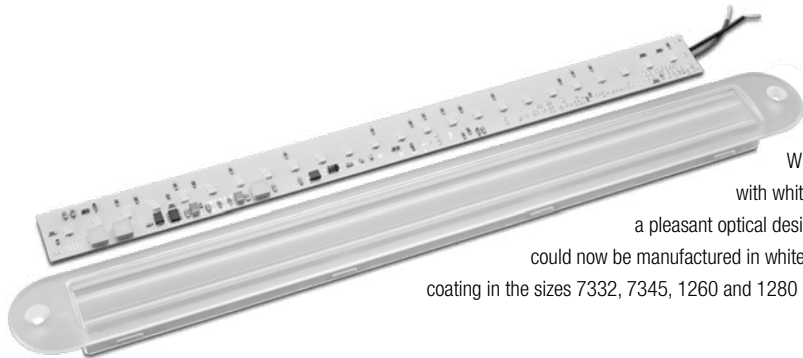

Application example Frensch GmbH

Würth Elektronik included now in their product range as well the WE-PD with white coating for a higher light efficiency used in LED applications. Hence a pleasant optical design, where beside the circuit board as well the mounted components could now be manufactured in white color, is possible. The SMD Power Inductor is available with white coating in the sizes 7332, 7345, 1260 and 1280 (all with plastic base). More information on page 275.

### Note

The ambient temperature when operating the WE-PD series of storage chokes at full current rating load should generally range from  $-40\text{ }^{\circ}\text{C}$  to  $+85\text{ }^{\circ}\text{C}$ . The self-heating of the component must be taken into account at higher ambient temperatures in order that the permissible solder joint temperature is not exceeded or the wire insulation damaged. The wire used can withstand a temperature of up to  $+150\text{ }^{\circ}\text{C}$ . The ferrite core itself may be used over a far greater temperature range (approx.  $-50\text{ }^{\circ}\text{C}$  to  $+250\text{ }^{\circ}\text{C}$  [Curie temperature]). However, in this case, the tolerance limits of the inductor may be exceeded due to the temperature dependence of permeability.

### Current derating at ambient temperature of $>85\text{ }^{\circ}\text{C}$

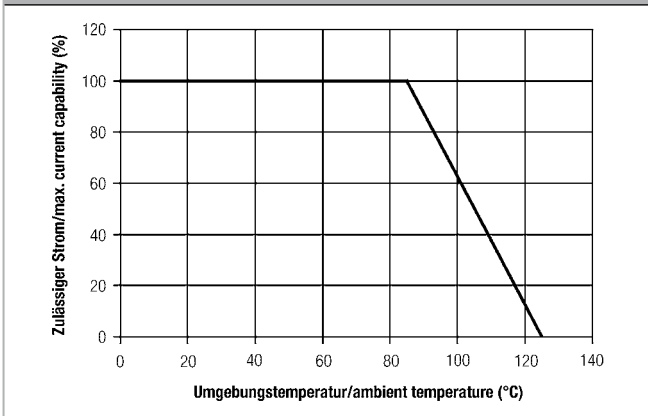

### Inductance vs. DC bias current

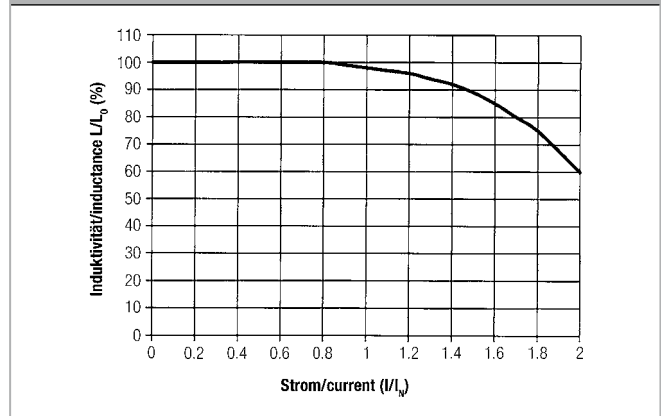

# WE-PD

## SMD Shielded Power Inductor

Size 7332

Electrical properties							
Order Code	L ( $\mu$ H)	Tolerance (%)	$I_R$ (A)	$I_{sat}$ (A)	$R_{DC\ typ.}$ ( $\Omega$ )	$R_{DC\ max.}$ ( $\Omega$ )	Qty.
744 778 005	0.54	$\pm 20$	5.60	9.00	0.0072	0.0085	1000
744 778 001	1.0		5.37	6.40	0.009	0.012	
744 778 002	2.2		4.02	4.80	0.014	0.020	
744 778 003	3.3		3.10	4.10	0.024	0.0325	
744 778 004	4.7		2.32	4.20	0.042	0.060	
744 778 10	10		1.83	2.20	0.068	0.072	
744 778 112	12		1.73	2.15	0.076	0.098	
744 778 115	15		1.51	1.75	0.100	0.130	
744 778 118	18		1.41	1.70	0.114	0.140	
744 778 122	22		1.38	1.40	0.119	0.190	
744 778 127	27		1.27	1.30	0.140	0.210	
744 778 133	33		1.22	1.15	0.153	0.240	
744 778 139	39		1.03	1.10	0.214	0.320	
744 778 147	47		0.85	1.00	0.315	0.360	
744 778 156	56		0.84	0.88	0.322	0.470	
744 778 168	68		0.74	0.84	0.417	0.520	
744 778 182	82		0.69	0.78	0.479	0.690	
744 778 20	100		0.62	0.76	0.585	0.790	
744 778 212	120		0.60	0.68	0.634	0.890	
744 778 215	150		0.56	0.53	0.72	1.270	
744 778 218	180		0.49	0.50	0.96	1.450	
744 778 222	220		0.43	0.42	1.22	1.650	
744 778 270	270		0.40	0.39	1.44	2.310	
744 778 233	330		0.32	0.35	2.28	2.620	
744 778 239	390		0.30	0.34	2.49	2.940	
744 778 24	470		0.30	0.31	2.60	4.180	
744 778 25	560		0.27	0.30	3.00	4.670	
744 778 26	680		0.22	0.22	4.50	5.730	
744 778 28	820		0.21	0.20	5.07	6.500	
744 778 30	1000		0.20	0.18	5.57	9.440	

$I_R$  referring to 40 K self-heating above ambient temperature  
 $I_{10\%}$  referring to inductance loss of 10% typ.

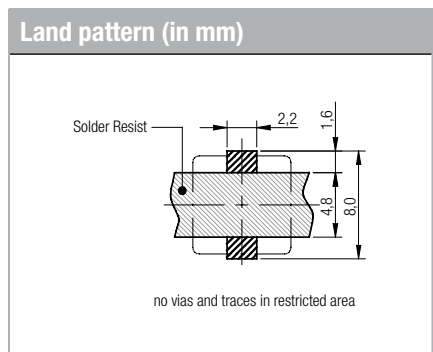
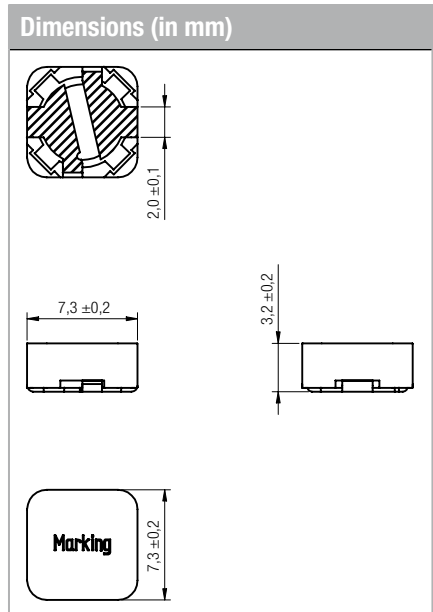

Electrical properties							
Order Code	L ( $\mu$ H)	Tolerance (%)	$I_R$ (A)	$I_{sat}$ (A)	$R_{DC\ typ.}$ ( $\Omega$ )	$R_{DC\ max.}$ ( $\Omega$ )	Qty.
744 777 001	1.0	±20	6.84	9.00	0.0084	0.010	1000
744 777 002	2.2		6.00	6.50	0.013	0.020	
744 777 003	3.3		5.00	4.60	0.025	0.030	
744 777 004	4.7		4.00	4.00	0.025	0.040	
744 777 10	10		2.00	2.60	0.045	0.049	
744 777 112	12		1.82	2.40	0.054	0.058	
744 777 115	15		1.60	2.20	0.070	0.081	
744 777 118	18		1.50	2.05	0.080	0.091	
744 777 122	22		1.41	1.70	0.090	0.110	
744 777 127	27		1.24	1.55	0.117	0.150	
744 777 133	33		1.13	1.40	0.140	0.170	
744 777 139	39		1.11	1.23	0.145	0.230	
744 777 147	47		1.03	1.10	0.170	0.260	
744 777 156	56		0.93	1.05	0.207	0.350	
744 777 168	68		0.87	0.95	0.239	0.380	
744 777 182	82		0.84	0.90	0.257	0.430	
744 777 20	100		0.79	0.75	0.290	0.610	
744 777 212	120		0.67	0.70	0.400	0.660	
744 777 215	150		0.52	0.63	0.660	0.880	
744 777 218	180		0.51	0.56	0.680	0.980	
744 777 222	220		0.44	0.54	0.920	1.170	
744 777 270	270		0.43	0.48	0.970	1.640	
744 777 233	330		0.39	0.45	1.150	1.860	
744 777 239	390		0.38	0.42	1.250	2.850	
744 777 24	470		0.29	0.34	1.600	3.010	
744 777 25	560		0.28	0.31	1.720	3.620	
744 777 26	680		0.23	0.28	2.600	4.630	
744 777 28	820		0.21	0.26	3.000	5.200	
744 777 30	1000		0.20	0.25	3.270	6.000	

$I_R$  referring to 40 K self-heating above ambient temperature  
 $I_{10\%}$  referring to inductance loss of 10% typ.

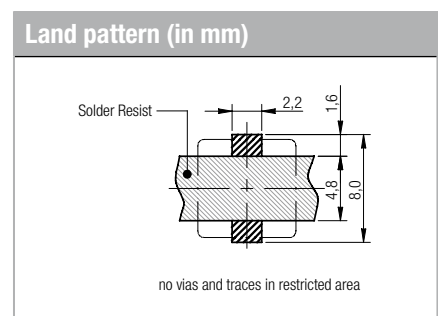
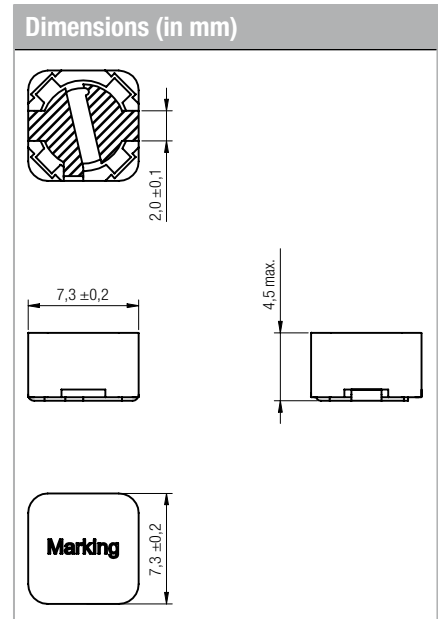

# WE-PD

## SMD Shielded Power Inductor

Size 1030

### Electrical properties

Order Code	L ( $\mu$ H)	Tolerance (%)	I <sub>R</sub> (A)	I <sub>sat</sub> (A)	R <sub>DC typ.</sub> ( $\Omega$ )	R <sub>DC max.</sub> ( $\Omega$ )	Qty.
744 771 301 5	1.5	±30	6.20	9.50	0.0137	0.016	1000
744 771 302 2	2.2	±30	5.10	8.50	0.0168	0.020	
744 771 303 3	3.3	±30	4.60	7.20	0.0204	0.024	
744 771 304 7	4.7	±30	4.00	6.00	0.026	0.031	
744 771 308 2	8.2	±30	3.00	4.70	0.041	0.049	
744 771 310 0	10	±20	2.60	4.10	0.052	0.062	
744 771 315 0	15	±20	2.20	3.40	0.074	0.089	
744 771 322 0	22	±20	1.70	2.70	0.111	0.133	
744 771 333 0	33	±20	1.35	2.20	0.170	0.204	
744 771 347 0	47	±20	1.20	1.90	0.207	0.248	
744 771 368 0	68	±20	1.10	1.60	0.275	0.330	
744 771 382 0	82	±20	0.95	1.50	0.349	0.419	
744 771 310 1	100	±20	0.90	1.40	0.398	0.478	
744 771 312 1	120	±20	0.85	1.25	0.498	0.598	
744 771 315 1	150	±20	0.70	1.10	0.570	0.684	
<b>NEW</b> 744 771 333 1	330	±20	0.48	0.73	1.230	1.500	
<b>NEW</b> 744 771 347 1	470	±20	0.42	0.65	1.850	2.200	
<b>NEW</b> 744 771 310 2	1000	±20	0.30	0.45	4.000	4.600	

I<sub>R</sub> referring to 40 K self-heating above ambient temperature  
I<sub>sat</sub> referring to inductance loss of 10% typ.

### Dimensions (in mm)

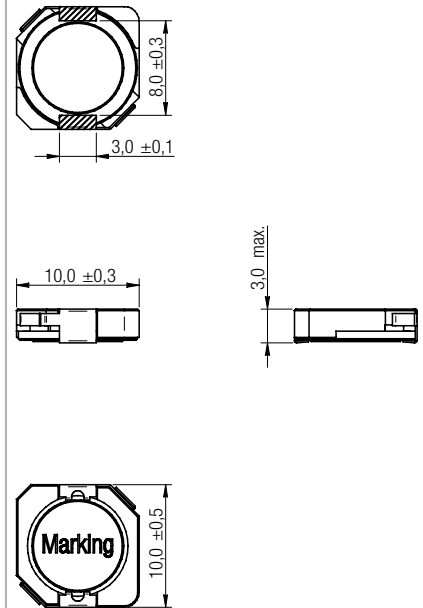

### Land pattern (in mm)

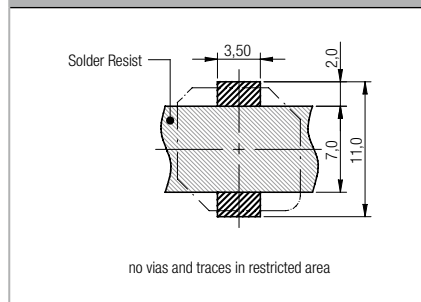

Also available  
with white coating

### Electrical properties

	Order Code	L ( $\mu$ H)	Tolerance (%)	$I_R$ (A)	$I_{sat}$ (A)	$R_{DC\ typ.}$ ( $\Omega$ )	$R_{DC\ max.}$ ( $\Omega$ )	Qty.
	744 771 401 5	1.5	$\pm 30$	10.0	12.5	0.00555	0.0066	500
	744 771 402 2	2.2	$\pm 30$	8.6	9.5	0.0068	0.0080	
	744 771 403 3	3.3	$\pm 30$	7.5	9.0	0.0089	0.0105	
	744 771 404 7	4.7	$\pm 30$	7.0	8.0	0.0104	0.0124	
	744 771 405 6	5.6	$\pm 30$	6.0	7.2	0.012	0.0144	
<b>NEW</b>	744 771 406 8	6.8	$\pm 30$	5.2	5.8	0.0185	0.022	
	744 771 410 0	10	$\pm 20$	4.3	5.0	0.023	0.027	
	744 771 415 0	15	$\pm 20$	3.5	4.1	0.036	0.043	
	744 771 422 0	22	$\pm 20$	3.0	3.6	0.042	0.050	
	744 771 433 0	33	$\pm 20$	2.5	2.9	0.066	0.079	
	744 771 447 0	47	$\pm 20$	2.2	2.5	0.083	0.099	
	744 771 456 0	56	$\pm 20$	2.0	2.3	0.101	0.121	
	744 771 468 0	68	$\pm 20$	1.9	2.2	0.110	0.132	
	744 771 482 0	82	$\pm 20$	1.6	1.9	0.147	0.176	
	744 771 410 1	100	$\pm 20$	1.5	1.8	0.165	0.198	
	744 771 415 1	150	$\pm 20$	1.2	1.4	0.251	0.300	
	744 771 422 1	220	$\pm 20$	1.00	1.20	0.366	0.439	
	744 771 433 1	330	$\pm 20$	0.71	1.00	0.655	0.750	
	744 771 447 1	470	$\pm 20$	0.60	0.82	0.960	1.100	
	744 771 468 1	680	$\pm 20$	0.51	0.71	1.220	1.140	
	744 771 410 2	1000	$\pm 20$	0.43	0.55	1.860	2.050	

$I_R$  referring to 40 K self-heating above ambient temperature  
 $L_{10\%}$  referring to inductance loss of 10% typ.

### Dimensions (in mm)

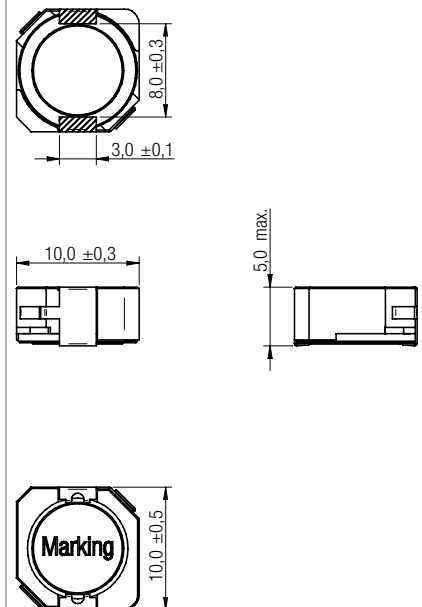

### Land pattern (in mm)

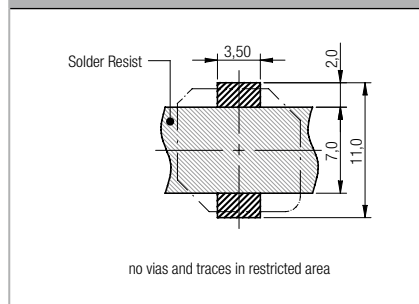

**Also available  
with white coating**

2

# WE-PD

## SMD Shielded Power Inductor

Size 1245

### Electrical properties

Order Code	L ( $\mu\text{H}$ )	Tolerance (%)	I <sub>R</sub> (A)	I <sub>sat</sub> (A)	R <sub>DC typ.</sub> ( $\Omega$ )	R <sub>DC max.</sub> ( $\Omega$ )	Qty.
744 771 590 6	0.6	±30	9.5	19.0	0.0045	0.0055	500
744 771 591 0	1.0	±30	8.5	13.9	0.0055	0.0070	
744 771 500 1	1.8	±30	7.6	10.2	0.0075	0.0095	
744 771 500 2	2.5	±30	6.8	8.5	0.0085	0.011	
744 771 500 3	3.3	±30	5.9	7.1	0.0115	0.013	
744 771 500 4	4.7	±30	5.2	6.3	0.0135	0.016	
744 771 500 6	6.8	±30	4.3	4.7	0.020	0.025	
744 771 510 0	10	±20	3.8	4.2	0.025	0.030	
744 771 512 0	12	±20	3.5	3.6	0.030	0.038	
744 771 518 0	18	±20	3.2	3.2	0.037	0.043	
744 771 522 0	22	±20	2.9	3.1	0.045	0.054	
744 771 533 0	33	±20	2.3	2.5	0.075	0.085	
744 771 547 0	47	±20	2.0	2.1	0.105	0.125	
744 771 510 1	100	±20	1.3	1.4	0.250	0.270	
744 771 522 1	220	±20	0.95	1.0	0.460	0.480	

I<sub>R</sub> referring to 40 K self-heating above ambient temperature  
I<sub>sat</sub> referring to inductance loss of 10% typ.

### Dimensions (in mm)

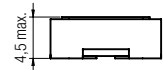
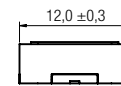
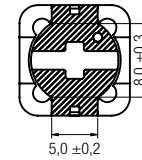

### Land pattern (in mm)

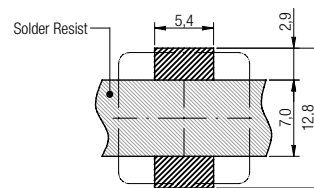

### Electrical properties

Order Code	L ( $\mu$ H)	Tolerance (%)	$I_R$ (A)	$I_{sat}$ (A)	$R_{DC\ typ.}$ ( $\Omega$ )	$R_{DC\ max.}$ ( $\Omega$ )	Qty.
744 771 001	1.5	±20	10.50	12.50	0.004	0.006	500
744 771 002	2.2		10.00	11.00	0.005	0.008	
744 771 003	3.5		9.25	9.00	0.005	0.008	
744 771 004	4.7		8.25	8.00	0.008	0.011	
744 771 006	6.8		5.60	6.00	0.015	0.022	
744 771 008	8.2		6.25	6.25	0.014	0.020	
744 771 10	10		5.00	5.50	0.018	0.025	
744 771 112	12		3.91	4.85	0.023	0.027	
744 771 115	15		3.75	4.55	0.025	0.030	
744 771 118	18		3.48	4.30	0.029	0.034	
744 771 122	22		3.37	3.77	0.031	0.036	
744 771 127	27		2.97	3.55	0.040	0.051	
744 771 133	33		2.68	3.00	0.049	0.057	
744 771 139	39		2.49	2.74	0.057	0.068	
744 771 147	47		2.21	2.60	0.072	0.075	
744 771 156	56		2.01	2.35	0.087	0.110	
744 771 168	68		1.91	2.19	0.096	0.120	
744 771 182	82		1.65	1.88	0.129	0.140	
744 771 20	100		1.53	1.70	0.150	0.160	
744 771 212	120		1.30	1.56	0.159	0.170	
744 771 215	150		1.21	1.43	0.185	0.230	
744 771 218	180		1.06	1.24	0.242	0.290	
744 771 220	220		0.96	1.20	0.290	0.400	
744 771 270	270		0.89	1.00	0.338	0.460	
744 771 233	330		0.78	0.97	0.442	0.510	
744 771 239	390		0.68	0.85	0.590	0.690	
744 771 24	470		0.64	0.80	0.660	0.770	
744 771 25	560		0.62	0.70	0.690	0.860	
744 771 26	680		0.55	0.68	0.880	1.200	
744 771 28	820		0.51	0.60	1.025	1.340	
744 771 30	1000	0.43	0.50	1.430	1.530		

$I_R$  referring to 40 K self-heating above ambient temperature  
 $I_{sat}$  referring to inductance loss of 10% typ.  
 Power Inductors in white coating are only available with Plastic Base.

### Dimensions (in mm)

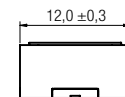
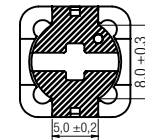

### Land pattern (in mm)

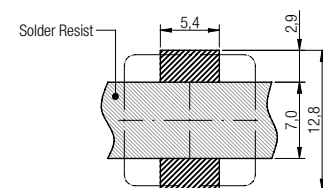

no vias and traces in restricted area

Also available  
with white coating

# WE-PD

## SMD Shielded Power Inductor

Size 1280

### Electrical properties

Order Code	L ( $\mu$ H)	Tolerance (%)	I <sub>R</sub> (A)	I <sub>sat</sub> (A)	R <sub>DC typ.</sub> ( $\Omega$ )	R <sub>DC max.</sub> ( $\Omega$ )	Qty.
744 770 09	0.47	+20/-25	23.5	26.4	0.003	0.003	500
744 770 08	0.75	+20/-25	19.8	21.0	0.003	0.004	
744 770 01	1.2	+40/-20	12.0	16.6	0.005	0.007	
744 770 02	2.4	+40/-20	10.1	14.3	0.009	0.012	
744 770 03	3.5	+40/-20	8.90	9.6	0.011	0.014	
744 770 04	4.7	+40/-20	8.50	9.3	0.012	0.016	
744 770 06	6.1	+40/-20	7.60	8.6	0.015	0.018	
744 770 07	7.6	+40/-20	7.40	8.0	0.016	0.020	
744 770 10	10	$\pm$ 20	6.20	6.6	0.019	0.022	
744 770 112	12	$\pm$ 20	5.90	6.3	0.021	0.024	
744 770 115	15	$\pm$ 20	5.00	6.0	0.024	0.027	
744 770 118	18	$\pm$ 20	4.20	5.4	0.032	0.039	
744 770 122	22	$\pm$ 20	4.10	5.0	0.033	0.043	
744 770 127	27	$\pm$ 20	3.70	3.8	0.035	0.046	
744 770 133	33	$\pm$ 20	3.20	3.6	0.047	0.064	
744 770 139	39	$\pm$ 20	3.00	3.5	0.053	0.073	
744 770 147	47	$\pm$ 20	2.70	3.0	0.076	0.10	
744 770 156	56	$\pm$ 20	2.40	2.9	0.085	0.11	
744 770 168	68	$\pm$ 20	2.30	2.5	0.090	0.14	
744 770 182	82	$\pm$ 20	2.25	2.45	0.086	0.16	
744 770 20	100	$\pm$ 20	2.20	2.4	0.102	0.22	
744 770 215	150	$\pm$ 20	1.80	1.8	0.136	0.28	
744 770 218	180	$\pm$ 20	1.40	1.6	0.188	0.35	
744 770 222	220	$\pm$ 20	1.30	1.49	0.247	0.39	
744 770 233	330	$\pm$ 20	1.10	1.1	0.349	0.64	
744 770 247	470	$\pm$ 20	0.90	0.9	0.496	0.98	
744 770 256	560	$\pm$ 20	0.80	0.9	0.593	1.07	
744 770 268	680	$\pm$ 20	0.70	0.8	0.840	1.46	
744 770 282	820	$\pm$ 20	0.60	0.8	0.936	1.64	
744 770 30	1000	$\pm$ 20	0.60	0.7	1.040	1.82	
<b>NEW</b> 744 770 315	1500	$\pm$ 20	0.50	0.5	1.450	1.90	

I<sub>R</sub> referring to 40 K self-heating above ambient temperature  
I<sub>sat</sub> referring to inductance loss of 10% typ.  
Power Inductors in white coating are only available with Plastic Base.

### Dimensions (in mm)

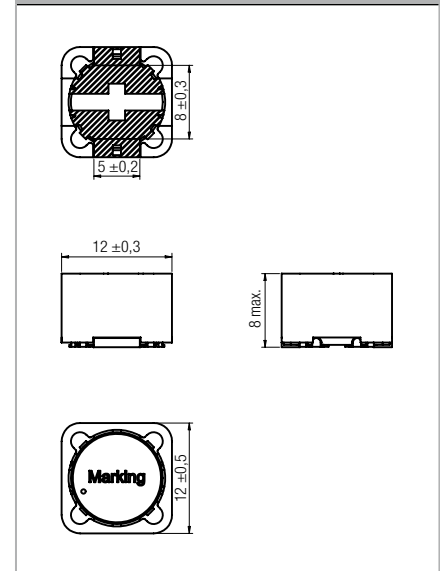

### Land pattern (in mm)

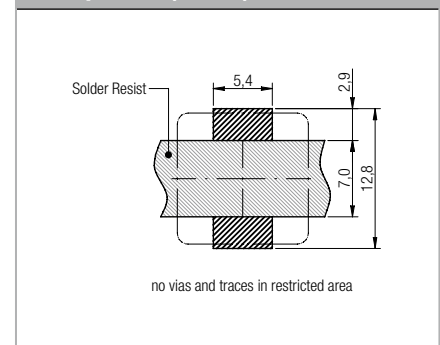

Also available  
with white coating

### Electrical properties

Order Code	L ( $\mu$ H)	Tolerance (%)	$I_R$ (A)	$I_{sat}$ (A)	$R_{DC\ typ.}$ ( $\Omega$ )	$R_{DC\ max.}$ ( $\Omega$ )	Qty.
744 770 900 1	1.0	±20	13.0	25.0	0.0038	0.006	250
744 770 900 2	2.2		11.5	20.0	0.0049	0.006	
744 770 900 3	3.5		11.0	16.5	0.0059	0.0085	
744 770 900 4	4.7		9.3	13.0	0.0074	0.011	
744 770 900 6	6.8		8.4	12.8	0.0091	0.014	
744 770 910 0	10		7.1	10.5	0.0129	0.021	
744 770 915 0	15		7.0	8.0	0.0207	0.026	
744 770 922 0	22		5.3	6.5	0.0233	0.028	
744 770 927 0	27		4.6	5.8	0.0300	0.040	
744 770 933 0	33		4.2	5.5	0.0368	0.045	
744 770 939 0	39		4.1	5.0	0.0440	0.056	
744 770 947 0	47		3.8	4.5	0.0459	0.060	
744 770 968 0	68		3.2	3.6	0.0686	0.0885	
744 770 982 0	82		2.75	3.4	0.0905	0.105	
744 770 910 1	100		2.50	3.1	0.100	0.110	
744 770 915 1	150		2.10	2.7	0.151	0.200	
744 770 922 1	220		1.80	2.2	0.193	0.300	
744 770 927 1	270		1.60	2.1	0.248	0.330	
744 770 933 1	330		1.50	1.7	0.363	0.430	
744 770 947 1	470		1.40	1.5	0.437	0.560	
744 770 968 1	680	1.10	1.3	0.660	0.825		
744 770 982 1	820	0.95	1.1	0.815	1.0		
744 770 910 2	1000	0.90	1.0	0.930	1.2		
744 770 915 2	1500	0.90	0.8	1.800	2.3		

$I_R$  referring to 40 K self-heating above ambient temperature  
 $I_{sat}$  referring to inductance loss of 10% typ.

### Dimensions (in mm)

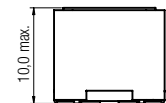
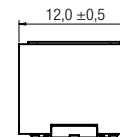
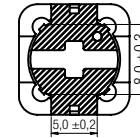

2

### Land pattern (in mm)

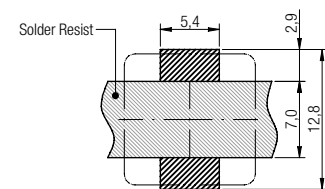

no vias and traces in restricted area

## SMD Shielded Power Inductor

Size 6033 with plastic base / Size 6050 with plastic base

### Electrical properties: Size 6033 with plastic base

Order Code	L (μH)	Tolerance (%)	I <sub>R</sub> (A)	I <sub>sat</sub> (A)	R <sub>DC typ.</sub> (Ω)	R <sub>DC max.</sub> (Ω)	Qty.
744 778 500 1	1.0	± 25	3.5	4.5	0.031	0.039	1000
744 778 500 2	2.2		2.9	3.3	0.043	0.054	
744 778 500 3	3.3		2.8	3.0	0.043	0.067	
744 778 500 4	4.7		2.65	2.5	0.060	0.078	
744 778 500 6	6.8		2.3	2.0	0.079	0.100	
744 778 510	10		1.9	1.6	0.100	0.125	
744 778 511 5	15		1.6	1.4	0.165	0.200	
744 778 512 2	22		1.35	1.1	0.210	0.250	
744 778 514 7	47		0.85	0.74	0.500	0.600	
744 778 520	100		0.65	0.50	0.950	1.060	

I<sub>s</sub> referring to 40 K self-heating above ambient temperature  
I<sub>10%</sub> referring to inductance loss of 10% typ.

**Because of the one piece construction these are more suitable for high vibration or shock applications!**

### Land pattern (in mm)

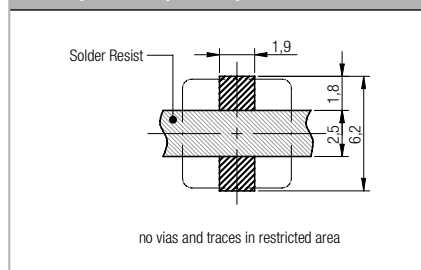

### Dimensions (in mm)

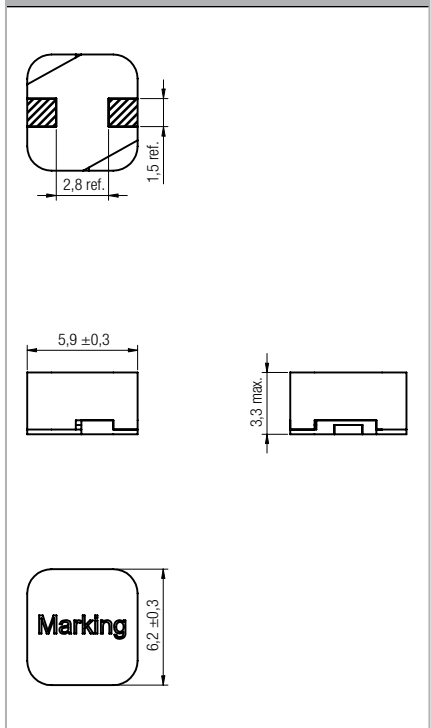

### Electrical properties: Size 6050 with plastic base

Order Code	L (μH)	Tolerance (%)	I <sub>R</sub> (A)	I <sub>sat</sub> (A)	R <sub>DC typ.</sub> (Ω)	R <sub>DC max.</sub> (Ω)	Qty.
744 778 600 1	1.0	±25	5.0	5.5	0.028	0.034	1000
744 778 600 2	2.2		3.5	4.0	0.040	0.049	
744 778 600 4	4.7		2.8	2.8	0.057	0.065	
744 778 600 6	6.8		2.5	2.3	0.062	0.075	
744 778 600 8	8.2		2.3	2.1	0.066	0.080	
744 778 610	10		2.1	1.8	0.074	0.088	
744 778 612 2	22		2.0	1.3	0.098	0.115	
744 778 614 7	47		1.4	0.8	0.260	0.295	

I<sub>s</sub> referring to 40 K self-heating above ambient temperature  
I<sub>10%</sub> referring to inductance loss of 10% typ.

**Because of the one piece construction these are more suitable for high vibration or shock applications!**

### Land pattern (in mm)

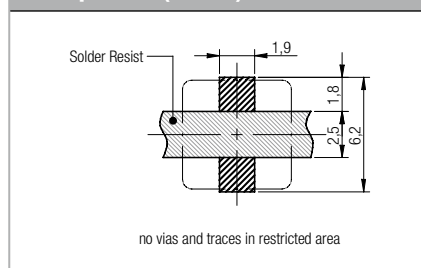

### Dimensions (in mm)

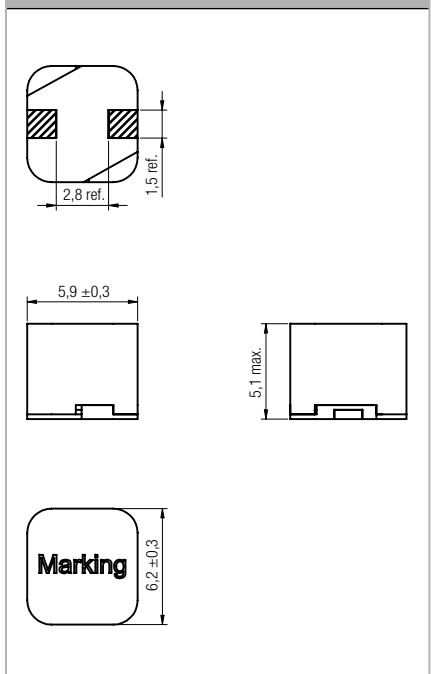

### Electrical properties

Order Code	L (µH)	Tolerance (%)	I <sub>R</sub> (A)	I <sub>sat</sub> (A)	R <sub>DC typ.</sub> (Ω)	R <sub>DC max.</sub> (Ω)	Qty.
744 778 900 1	1.0	±20	5.37	6.40	0.010	0.012	1000
744 778 900 2	2.2		4.02	4.80	0.019	0.020	
744 778 900 3	3.3		3.42	4.20	0.024	0.030	
744 778 900 4	4.7		2.90	3.90	0.033	0.035	
744 778 900 6	6.8		2.50	2.75	0.0415	0.044	
744 778 910	10		1.83	2.2	0.064	0.072	
744 778 911 2	12		1.73	1.90	0.076	0.098	
744 778 911 5	15		1.51	1.75	0.100	0.13	
744 778 911 8	18		1.41	1.70	0.114	0.14	
744 778 912 2	22		1.38	1.40	0.119	0.19	
744 778 912 7	27		1.27	1.35	0.130	0.21	
744 778 913 3	33		1.22	1.15	0.153	0.24	
744 778 913 9	39		1.03	1.10	0.209	0.32	
744 778 914 7	47		0.85	1.00	0.315	0.36	
744 778 915 6	56		0.84	0.90	0.335	0.47	
744 778 916 8	68		0.74	0.84	0.427	0.52	
744 778 918 2	82		0.69	0.78	0.470	0.69	
744 778 920	100		0.62	0.76	0.585	0.79	
744 778 921 2	120		0.60	0.68	0.563	0.89	
744 778 921 5	150		0.56	0.53	0.72	1.27	
744 778 921 8	180		0.49	0.50	0.96	1.45	
744 778 922 2	220		0.43	0.42	1.35	1.65	
744 778 927 0	270		0.40	0.39	1.47	2.31	
744 778 923 3	330		0.32	0.35	2.28	2.62	
744 778 923 9	390		0.30	0.34	2.49	2.94	
744 778 924	470		0.30	0.31	2.60	4.18	
744 778 925	560		0.27	0.30	3.00	4.67	
744 778 926	680		0.22	0.22	4.50	5.73	
744 778 928	820		0.21	0.20	4.99	6.54	
744 778 930	1000		0.20	0.18	5.57	9.44	

I<sub>R</sub> referring to 40 K self-heating above ambient temperature  
 I<sub>sat</sub> referring to inductance loss of 10% typ.

### Dimensions (in mm)

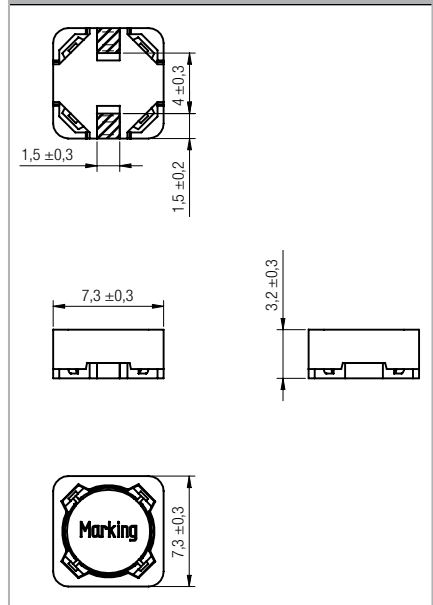

### Land pattern (in mm)

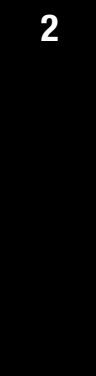
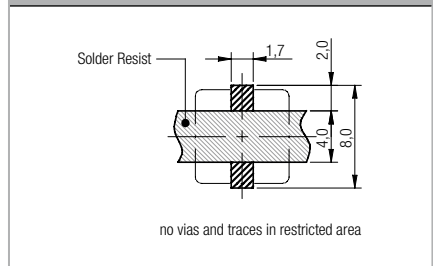

**Because of the one piece construction these are more suitable for high vibration or shock applications!**

**Also available with white coating**

# WE-PD

## SMD Shielded Power Inductor

Size 7345 with plastic base

Electrical properties							
Order Code	L ( $\mu$ H)	Tolerance (%)	$I_R$ (A)	$I_{sat}$ (A)	$R_{DC\ typ.}$ ( $\Omega$ )	$R_{DC\ max.}$ ( $\Omega$ )	Qty.
744 777 900 1	1.0	$\pm 20$	5.30	9.50	0.010	0.011	1000
744 777 900 15	1.5		4.30	7.30	0.015	0.018	
744 777 900 2	2.2		4.20	6.00	0.016	0.020	
744 777 900 3	3.3		3.30	4.50	0.026	0.030	
744 777 900 4	4.7		3.16	4.40	0.028	0.032	
744 777 900 6	6.8		2.91	3.30	0.033	0.035	
744 777 900 8	8.2		2.70	3.00	0.047	0.053	
744 777 910	10		2.00	2.60	0.045	0.049	
744 777 911 2	12		1.82	2.40	0.050	0.058	
744 777 911 5	15		1.60	2.20	0.070	0.081	
744 777 911 8	18		1.50	2.05	0.080	0.091	
744 777 912 2	22		1.41	1.70	0.090	0.11	
744 777 912 7	27		1.24	1.55	0.120	0.15	
744 777 913 3	33		1.13	1.40	0.140	0.17	
744 777 913 9	39		1.11	1.23	0.145	0.23	
744 777 914 7	47		1.03	1.10	0.190	0.26	
744 777 915 6	56		0.93	1.05	0.228	0.35	
744 777 916 8	68		0.87	0.95	0.239	0.38	
744 777 918 2	82		0.84	0.90	0.250	0.43	
744 777 920	100		0.79	0.75	0.290	0.38	
744 777 921 2	120		0.67	0.70	0.396	0.66	
744 777 921 5	150		0.52	0.63	0.529	0.88	
744 777 921 8	180		0.51	0.56	0.603	0.98	
744 777 922 2	220		0.44	0.54	0.92	1.17	
744 777 927 0	270		0.43	0.48	1.09	1.64	
744 777 923 3	330		0.39	0.45	1.15	1.86	
744 777 923 9	390		0.38	0.42	1.40	2.85	
744 777 924	470		0.29	0.34	1.60	3.01	
744 777 925	560		0.28	0.31	1.72	3.62	
744 777 926	680		0.23	0.28	2.60	4.63	
744 777 928	820	0.21	0.26	2.96	5.20		
744 777 930	1000	0.20	0.25	3.27	6.00		

$I_R$  referring to 40 K self-heating above ambient temperature  
 $I_{10\%}$  referring to inductance loss of 10% typ.

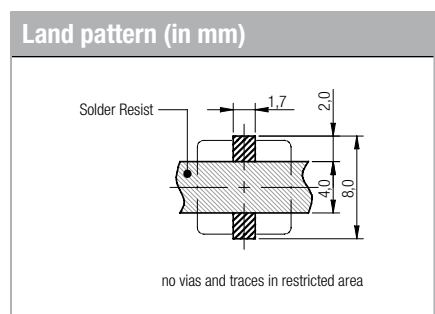
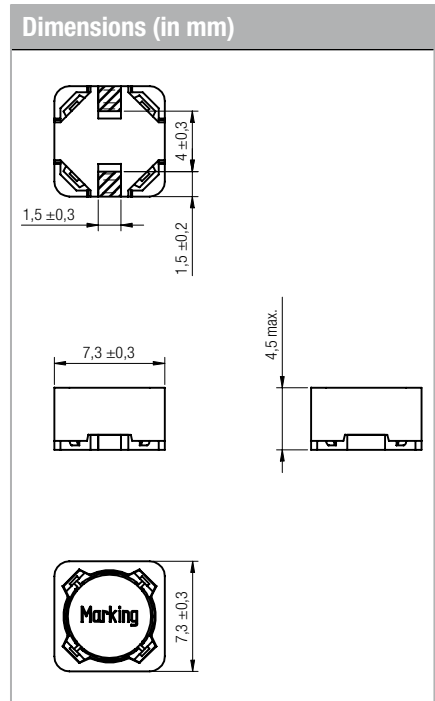

Because of the one piece construction these are more suitable for high vibration or shock applications!

Also available with white coating