

100325 Low Power Hex ECL-to-TTL Translator

General Description

The 100325 is a hex translator for converting F100K logic levels to TTL logic levels. Differential inputs allow each circuit to be used as an inverting, non-inverting or differential receiver. An internal reference voltage generator provides V_{BB} for single-ended operation, or for use in Schmitt trigger applications. All inputs have 50k Ω pull-down resistors. When the inputs are either unconnected or at the same potential the outputs will go low.

When used in single-ended operation the apparent input threshold of the true inputs is 20mV to 40mV higher (positive) than the threshold of the complementary inputs. The V_{EE} and V_{TTL} power may be applied in either order.

Features

- Pin/function compatible with 100125
- Meets 100125 AC specifications
- 50% power reduction of the 100125
- Differential inputs with built in offset
- Standard FAST® outputs
- 2000V ESD protection
- -4.2V to -5.7V operating range
- Available to industrial grade temperature range
- Available to MIL-STD-883

Logic Diagram

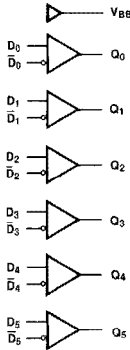

TL/F/9879-4

Pin Names	Description
D ₀ -D ₅	Data Inputs
D ₀ -D ₅	Inverting Data Inputs
Q ₀ -Q ₅	Data Outputs

Connection Diagrams

24-Pin DIP/SOIC

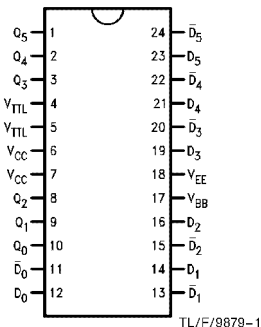

TL/F/9879-1

28-Pin PCC

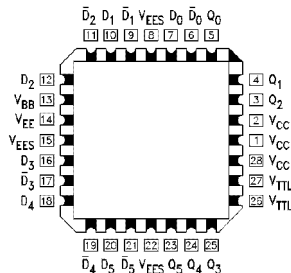

TL/F/9879-3

24-Pin Quad Cerpak

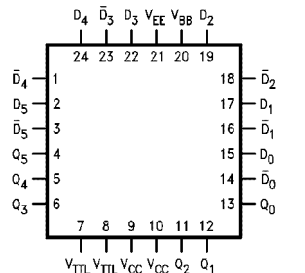

TL/F/9879-2

FAST® is a registered trademark of National Semiconductor Corporation.

Absolute Maximum Ratings

Above which the useful life may be impaired. (Note 1)

If Military/Aerospace specified devices are required, please contact the National Semiconductor Sales Office/Distributors for availability and specifications.

Storage Temperature (T _{STG})	65°C to +150°C
Maximum Junction Temperature (T _J)	
Ceramic	+175°C
Plastic	+150°C
V _{EE} Pin Potential to Ground Pin	7.0V to +0.5V
V _{TTL} Pin Potential to Ground Pin	0.5V to +6.0V
Input Voltage (DC)	V _{EE} to +0.5V
Voltage Applied to Output in HIGH State (with V _{CC} = 0V)	0.5V to V _{CC}
Current Applied to Output in LOW State (Max)	twice the rated I _{OL} (mA)
ESD (Note 2)	> 2000V

Note 1: Absolute maximum ratings are those values beyond which the device may be damaged or have its useful life impaired. Functional operation under these conditions is not implied.

Note 2: ESD testing conforms to MIL-STD-883, Method 3015.

Recommended Operating Conditions

Case Temperature (T _C)	
Commercial	0°C to +85°C
Industrial	-40°C to +85°C
Military	55°C to +125°C
Supply Voltage (V _{EE})	5.7V to 4.2V

Truth Table

Inputs		Outputs
D _n	\bar{D}_n	Q _n
L	H	L
H	L	H
L	L	L
H	H	L
Open	Open	L
V _{EE}	V _{EE}	L
L	V _{BB}	L
H	V _{BB}	H
V _{BB}	L	H
V _{BB}	H	L

H = HIGH Voltage Level
L = LOW Voltage Level

Commercial Version

DC Electrical Characteristics

V_{EE} = 4.2V to 5.7V, V_{CC} = GND, V_{TTL} = +4.5V to 5.5V, T_C = 0°C to +85°C (Note 3)

Symbol	Parameter	Min	Typ	Max	Units	Conditions
V _{BB}	Output Reference Voltage	1380	1320	1260	mV	V _{BB} - 2.1 mA
V _{IH}	Single-Ended Input HIGH Voltage	-1165		-870	mV	Guaranteed HIGH Signal for All Inputs (with One Input Tied to V _{BB})
V _{IL}	Single-Ended Input LOW Voltage	1830		1475	mV	Guaranteed LOW Signal for All Inputs (with One Input Tied to V _{BB})
V _{OH}	Output HIGH Voltage	2.5			V	I _{OH} = 2.0 mA
V _{OL}	Output LOW Voltage			0.5	V	I _{OL} = 20 mA
V _{DIFF}	Input Voltage Differential	150			mV	Required for Full Output Swing
V _{CM}	Common Mode Voltage	V _{CC} - 2.0		V _{CC} - 0.5	V	V _{IH} - V _{IL} (Max) or V _{IL} (Min)

Commercial Version (Continued)

DC Electrical Characteristics (Continued)

$V_{EE} = -4.2V$ to $-5.7V$, $V_{CC} = GND$, $V_{TTL} = +4.5V$ to $5.5V$, $T_C = 0^\circ C$ to $+85^\circ C$ (Note 3)

Symbol	Parameter	Min	Typ	Max	Units	Conditions
I_{IH}	Input HIGH Current			350	μA	$V_{IN} = V_{IH(Max)}$, $D_0-D_5 = V_{BB}$, $\overline{D_0-D_5} = V_{IL(Min)}$
I_{IL}	Input LOW Current	0.5			μA	$V_{IN} = V_{IL(Min)}$, $D_0-D_5 = V_{BB}$
I_{OS}	Output Short-Circuit Current	-150		-60	mA	$V_{OUT} = GND^*$
I_{EE}	V_{EE} Power Supply Current	37	27	17	mA	$D_0-D_5 = V_{BB}$
I_{TTL}	V_{TTL} Power Supply Current		45	65	mA	$D_0-D_5 = V_{BB}$

*Test one output at a time.

Note 3: The specified limits represent the "worst case" value for the parameter. Since these values normally occur at the temperature extremes, additional noise immunity and guardbanding can be achieved by decreasing the allowable system operating ranges. Conditions for testing shown in the tables are chosen to guarantee operation under "worst case" conditions.

DIP AC Electrical Characteristics

$V_{EE} = -4.2V$ to $-5.7V$, $V_{CC} = GND$, $V_{TTL} = +4.5V$ to $+5.5V$

Symbol	Parameter	$T_C = 0^\circ C$		$T_C = +25^\circ C$		$T_C = +85^\circ C$		Units	Conditions
		Min	Max	Min	Max	Min	Max		
t_{PLH} t_{PHL}	Propagation Delay Data to Output	0.80	3.50	0.90	3.70	1.00	4.00	ns	$C_L = 15$ pF Figures 1 and 2
t_{PLH} t_{PHL}	Propagation Delay Data to Output	1.60	4.30	1.70	4.50	1.80	4.80	ns	$C_L = 50$ pF Figures 1 and 3

SOIC, PCC and Cerpak AC Electrical Characteristics

$V_{EE} = -4.2V$ to $-5.7V$, $V_{CC} = GND$, $V_{TTL} = +4.5V$ to $+5.5V$

Symbol	Parameter	$T_C = 0^\circ C$		$T_C = +25^\circ C$		$T_C = +85^\circ C$		Units	Conditions
		Min	Max	Min	Max	Min	Max		
t_{PLH} t_{PHL}	Propagation Delay Data to Output	0.80	3.30	0.90	3.50	1.00	3.80	ns	$C_L = 15$ pF Figures 1 and 2
t_{PLH} t_{PHL}	Propagation Delay Data to Output	1.60	4.10	1.70	4.30	1.80	4.60	ns	$C_L = 50$ pF Figures 1 and 3
t_{OSHL}	Maximum Skew Common Edge Output-to-Output Variation Data to Output Path		0.65		0.65		0.65	ns	PCC Only (Note 1)
t_{OSLH}	Maximum Skew Common Edge Output-to-Output Variation Data to Output Path		0.65		0.65		0.65	ns	PCC Only (Note 1)
t_{OST}	Maximum Skew Opposite Edge Output-to-Output Variation Data to Output Path		2.20		2.20		2.20	ns	PCC Only (Note 1)
t_{PS}	Maximum Skew Pin (Signal) Transition Variation Data to Output Path		2.10		2.10		2.10	ns	PCC Only (Note 1)

Note 1: Output-to-Output Skew is defined as the absolute value of the difference between the actual propagation delay for any outputs within the same packaged device. The specifications apply to any outputs switching in the same direction either HIGH to LOW (t_{OSLH}), or LOW to HIGH (t_{OSLH}), or in opposite directions both HL and LH (t_{OST}). Parameters t_{OSL} and t_{PS} guaranteed by design.

Industrial Version

PCC DC Electrical Characteristics (Note)

$V_{EE} = -4.2V$ to $-5.7V$, $V_{CC} = GND$, $T_C = 40^\circ C$ to $+85^\circ C$

Symbol	Parameter	$T_C = -40^\circ C$		$T_C = 0^\circ C$ to $+85^\circ C$		Units	Conditions
		Min	Max	Min	Max		
V_{BB}	Output Reference Voltage	-1395	-1255	-1380	-1260	mV	$I_{V_{BB}} = -2.1$ mA
V_{IH}	Single-Ended Input HIGH Voltage	-1170	-870	-1165	-870	mV	Guaranteed HIGH Signal for All Inputs (with One Input Tied to V_{BB})
V_{IL}	Single-Ended Input LOW Voltage	-1830	-1480	-1830	-1475	mV	Guaranteed LOW Signal for All Inputs (with One Input Tied to V_{BB})
V_{OH}	Output HIGH Voltage	2.5		2.5		V	$I_{OH} = -2.0$ mA
V_{OL}	Output LOW Voltage		0.5		0.5	V	$I_{OL} = 20$ mA
V_{DIFF}	Input Voltage Differential	150		150		mV	Required for Full Output Swing
V_{CM}	Common Mode Voltage	$V_{CC} - 2.0$	$V_{CC} - 0.5$	$V_{CC} - 2.0$	$V_{CC} - 0.5$	V	
I_{IH}	Input HIGH Current		450		350	μA	$V_{IN} = V_{IH (Max)}$, $D_0 - D_5 = V_{BB}$, $D_0 - D_5 = V_{IL (Min)}$
I_{IL}	Input LOW Current	0.5		0.5		μA	$V_{IN} = V_{IL (Min)}$, $D_0 - D_5 = V_{BB}$
I_{OS}	Output Short-Circuit Current	-150	-60	-150	-60	mA	$V_{OUT} = GND^*$
I_{EE}	V_{EE} Power Supply Current	-37	-15	-37	-17	mA	$D_0 - D_5 = V_{BB}$
I_{TTL}	V_{TTL} Power Supply Current		65		65	mA	$D_0 - D_5 = V_{BB}$

*Test one output at a time.

Note: The specified limits represent the "worst case" value for the parameter. Since these values normally occur at the temperature extremes, additional noise immunity and guardbanding can be achieved by decreasing the allowable system operating ranges. Conditions for testing shown in the tables are chosen to guarantee operation under "worst case" conditions.

PCC AC Electrical Characteristics

$V_{EE} = -4.2V$ to $-5.7V$, $V_{CC} = GND$, $V_{TTL} = +4.5V$ to $+5.5V$

Symbol	Parameter	$T_C = -40^\circ C$		$T_C = +25^\circ C$		$T_C = +85^\circ C$		Units	Conditions
		Min	Max	Min	Max	Min	Max		
t_{PLH}	Propagation Delay Data to Output	0.80	3.30	0.90	3.50	1.00	3.80	ns	$C_L = 15$ pF Figures 1 and 2
t_{PLH}	Propagation Delay Data to Output	1.60	4.10	1.70	4.30	1.80	4.60	ns	$C_L = 50$ pF Figures 1 and 3

Military Version

DC Electrical Characteristics

$V_{EE} = -4.2V$ to $-5.7V$, $V_{CC} = V_{CCA} = GND$, $T_C = -55^\circ C$ to $+125^\circ C$, $C_L = 50$ pF, $V_{TTL} = +4.5V$ to $+5.5V$

Symbol	Parameter	Min	Max	Units	T_C	Conditions	Notes
V_{BB}	Output Reference Voltage	-1380	-1260	mV	0°C to +125°C	$I_{V_{BB}} = -3 \mu A$, $V_{EE} = -4.2V$ $I_{V_{BB}} = 2.1$ mA	1, 2, 3
		-1396	-1260		-55°C		
V_{IH}	Input HIGH Voltage	-1165	-870	mV	-55°C to +125°C	Guaranteed HIGH Signal for All Inputs (with One Input Tied to V_{BB})	1, 2, 3, 4
V_{IL}	Input LOW Voltage	-1830	-1475	mV	-55°C to +125°C	Guaranteed LOW Signal for All Inputs (with One Input Tied to V_{BB})	1, 2, 3, 4
V_{OH}	Output HIGH Voltage	2.5		mV	0°C to +125°C	$I_{OH} = 2.0$ mA	$V_{IN} = V_{IH}(\text{Max})$ or $V_{IL}(\text{Min})$
		2.4			-55°C		
V_{OL}	Output LOW Voltage		0.5	mV	-55°C to +125°C	$I_{OL} = 20$ mA	1, 2, 3
V_{DIFF}	Input Voltage Differential	150		mV	55°C to +125°C	Required for Full Output Swing	1, 2, 3
V_{CM}	Common Mode Voltage	-2000	-500	mV	-55°C to +125°C		1, 2, 3, 4
I_{IH}	Input HIGH Current		350	μA	0°C to +125°C	$V_{IN} = V_{IH}(\text{Max})$, $D_0-D_5 = V_{BB}$, $D_0-D_5 = V_{IL}(\text{Min})$	1, 2, 3
			500		-55°C		
I_{IL}	Input LOW Current	0.50		μA	-55°C to +125°C	$V_{IN} = V_{IL}(\text{Min})$, $D_0-D_5 = V_{BB}$	1, 2, 3
I_{OS}	Output Short Circuit Current	-150	-60	mA	-55°C to +125°C	$V_{OUT} = GND$ Test One Output at a Time	1, 2, 3
I_{OEX}	Output HIGH Leakage Current		250	μA	-55°C to +125°C	$V_{OUT} = 5.5V$	1, 2, 3
I_{EE}	V_{EE} Power Supply Current	-35	-12	mA	-55°C to +125°C	$D_0-D_5 = V_{BB}$	1, 2, 3
I_{TTL}	V_{TTL} Power Supply Current		65	mA	-55°C to +125°C	$D_0-D_5 = V_{BB}$	1, 2, 3

Note 1: F100K 300 Series cold temperature testing is performed by temperature soaking (to guarantee junction temperature equals $-55^\circ C$), then testing immediately without allowing for the junction temperature to stabilize due to heat dissipation after power-up. This provides "cold start" specs which can be considered a worst case condition at cold temperatures.

Note 2: Screen tested 100% on each device at $-55^\circ C$, $+25^\circ C$, and $+125^\circ C$, Subgroups 1, 2, 3, 7, and 8.

Note 3: Sample tested (Method 5005, Table I) on each manufactured lot at $-55^\circ C$, $+25^\circ C$, and $+125^\circ C$, Subgroups A1, 2, 3, 7, and 8.

Note 4: Guaranteed by applying specified input condition and testing V_{O+}/V_{O-} .

AC Electrical Characteristics

$V_{EE} = -4.2V$ to $-5.7V$, $V_{CC} = GND$, $V_{TTL} = +4.5V$ to $+5.5V$

Symbol	Parameter	$T_C = -55^\circ C$		$T_C = +25^\circ C$		$T_C = +125^\circ C$		Units	Conditions	Notes
		Min	Max	Min	Max	Min	Max			
t_{PLH}	Propagation Delay Data to Output	1.50	5.00	1.60	4.70	1.70	5.70	ns	$C_L = 50$ pF <i>Figures 1 and 3</i>	1, 2, 3
t_{PHL}										

Note 1: F100K 300 Series cold temperature testing is performed by temperature soaking (to guarantee junction temperature equals $-55^\circ C$), then testing immediately after power-up. This provides "cold start" specs which can be considered a worst case condition at cold temperatures.

Note 2: Screen tested 100% on each device at $+25^\circ C$, temperature only, Subgroup A9.

Note 3: Sample tested (Method 5005, Table I) on each manufactured lot at $+25^\circ C$, Subgroup A9, and at $+125^\circ C$ and $-55^\circ C$ temperatures, Subgroups A10 and A11.

Note 4: Not tested at $+125^\circ C$, $+125^\circ C$, and $-55^\circ C$ temperature (design characterization data).

Switching Waveform

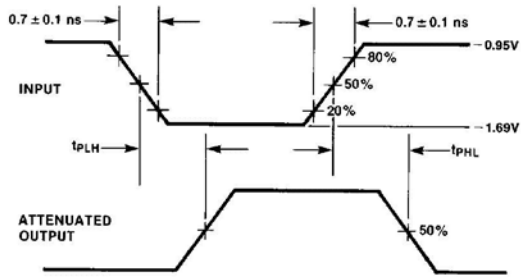
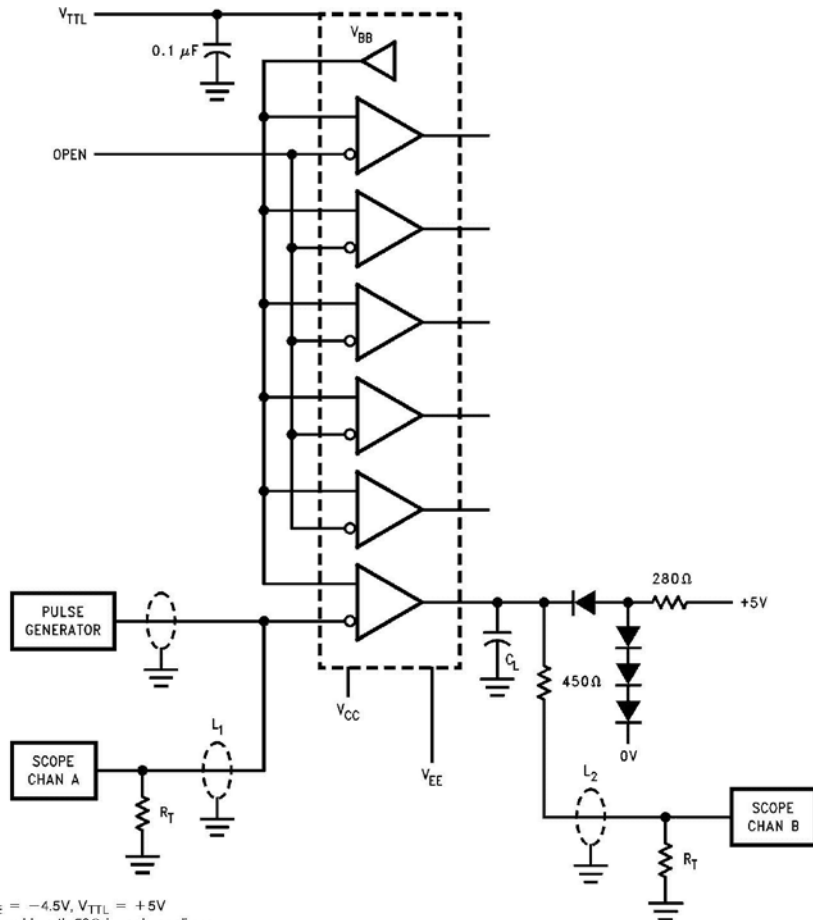

FIGURE 1. Propagation Delay

TL/F/9879-6

Test Circuits



Notes:
 $V_{CC} = 0V$, $V_{EE} = -4.5V$, $V_{TTL} = +5V$
 L_1 and L_2 = equal length 50Ω impedance lines
 $R_T = 50\Omega$ terminator internal to scope
 Decoupling $0.1 \mu F$ from GND to V_{CC} , V_{EE} and V_{TTL}
 All unused outputs are loaded with 500Ω to GND
 C_L = Fixture and stray capacitance = $15 pF$

FIGURE 2. AC Test Circuit for 15 pF Loading

TL/F/9879-5

Test Circuits (Continued)

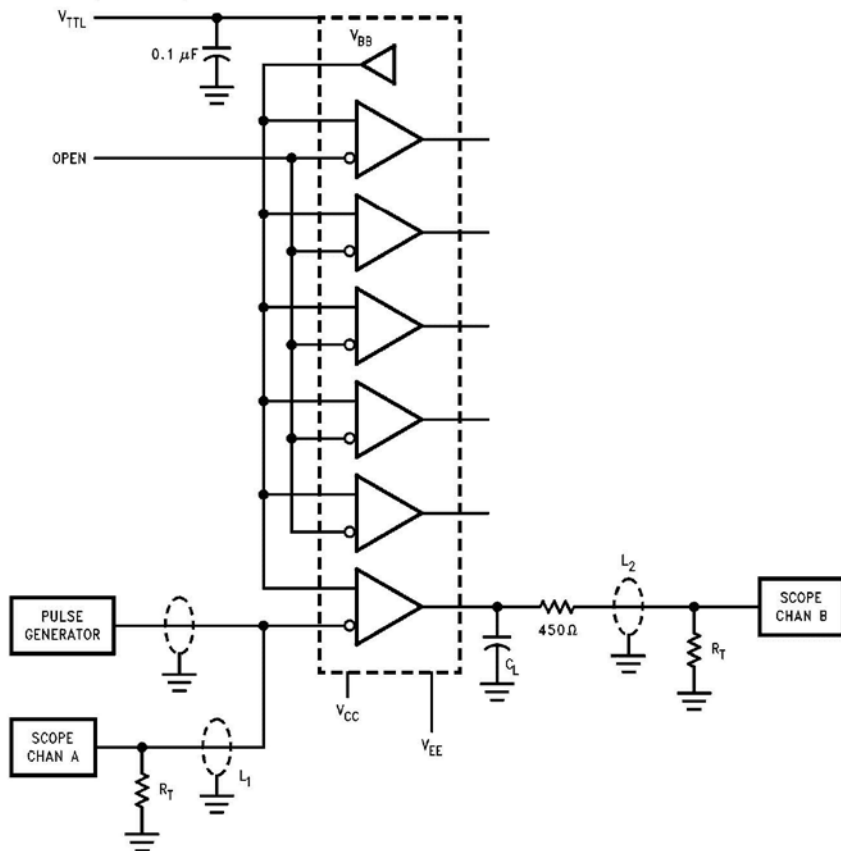

Notes:

$V_{CC} = 0V$, $V_{EE} = -4.5V$, $V_{TTL} = +5V$
 L_1 and L_2 = equal length 50 Ω impedance lines
 R_T = 50 Ω terminator internal to scope
 Decoupling 0.1 μF from GND to V_{CC} , V_{EE} and V_{TTL}
 All unused outputs are loaded with 500 Ω to GND
 C_L = Fixture and stray capacitance = 50 pF

TL/F/9879-8

FIGURE 3. AC Test Circuit for 50 pF Loading

Ordering Information

The device number is used to form part of a simplified purchasing code where a package type and temperature range are defined as follows:

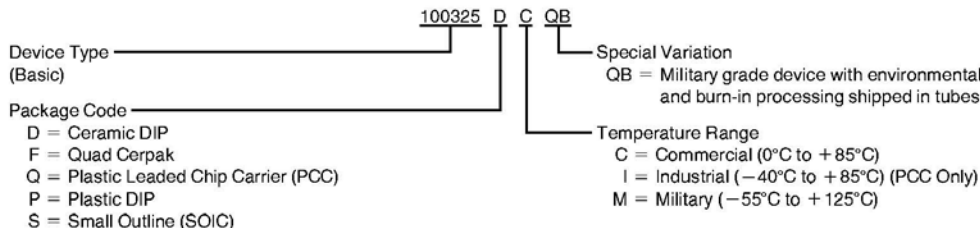

Physical Dimensions inches (millimeters)

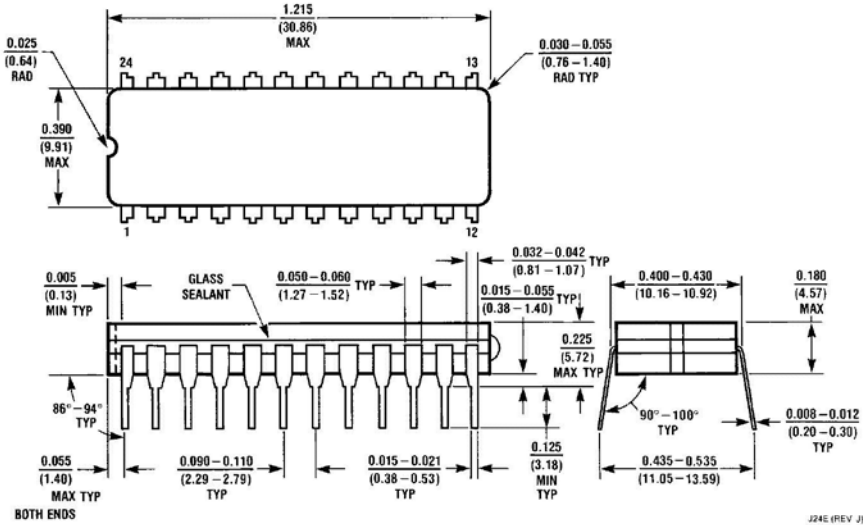

24 Lead Ceramic Dual-In-Line Package (0.400" Wide) (D)
NS Package Number J24E

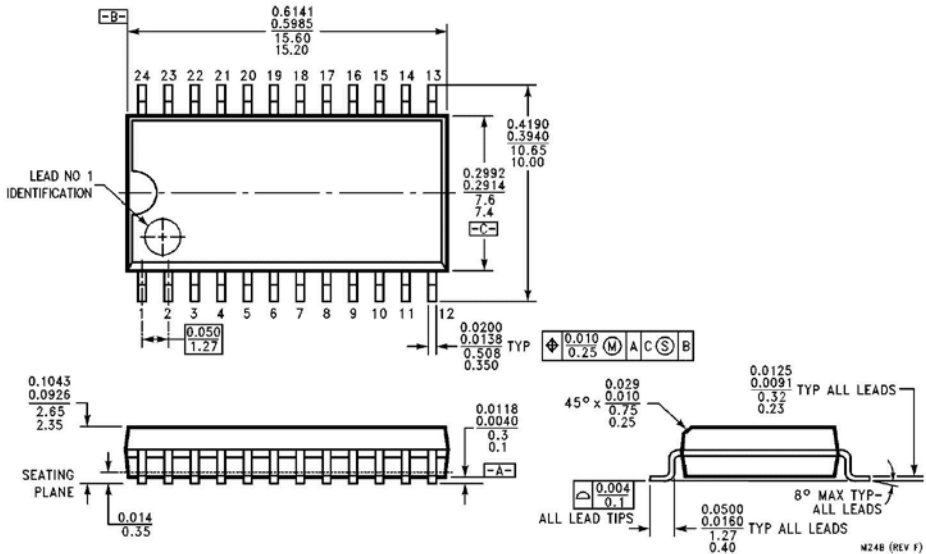

24 Lead Package (S)
NS Package Number M24B

Physical Dimensions inches (millimeters) (Continued)

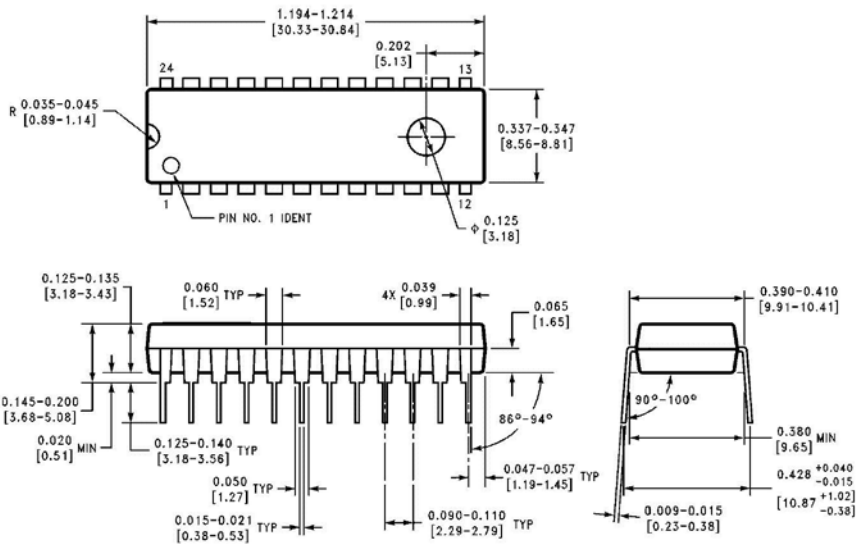

24 Lead Plastic DIP Package (P)
NS Package Number N24E

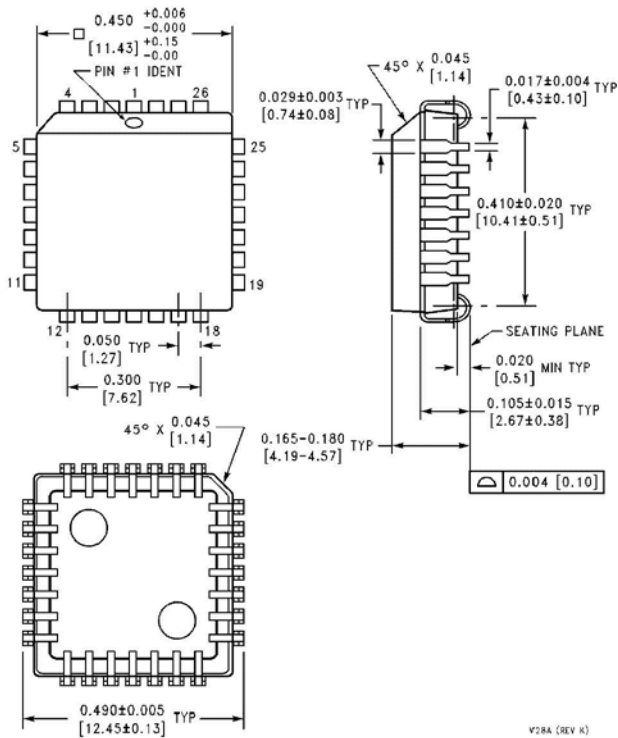

28 Lead Plastic Chip Carrier (Q)
NS Package Number V28A

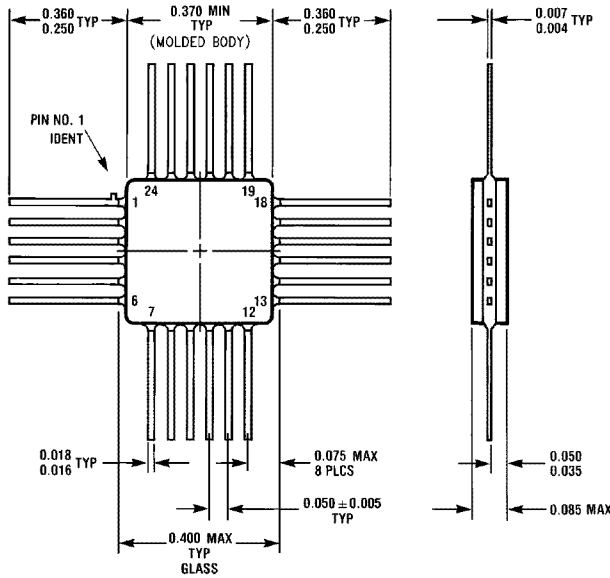

W24B (REV D)

24 Lead Quad Cerpak (F)
NS Package Number W24B

LIFE SUPPORT POLICY

NATIONAL'S PRODUCTS ARE NOT AUTHORIZED FOR USE AS CRITICAL COMPONENTS IN LIFE SUPPORT DEVICES OR SYSTEMS WITHOUT THE EXPRESS WRITTEN APPROVAL OF THE PRESIDENT OF NATIONAL SEMICONDUCTOR CORPORATION. As used herein:

1. Life support devices or systems are devices or systems which, (a) are intended for surgical implant into the body, or (b) support or sustain life, and whose failure to perform, when properly used in accordance with instructions for use provided in the labeling, can be reasonably expected to result in a significant injury to the user.
2. A critical component is any component of a life support device or system whose failure to perform can be reasonably expected to cause the failure of the life support device or system, or to affect its safety or effectiveness.



National Semiconductor Corporation
1111 West Bardin Road
Arlington, TX 76017
Tel: 1(800) 272-9959
Fax: 1(800) 737-7018

National Semiconductor Europe
Fax: (+49) 0-180-530 85 86
Email: crjwge@tevm2.nsc.com
Deutsch Tel: (+49) 0-180-530 85 85
English Tel: (+49) 0-180-532 78 32
Français Tel: (+49) 0-180-532 93 58
Italiano Tel: (+49) 0-180-534 16 80

National Semiconductor Hong Kong Ltd.
13th Floor, Straight Block,
Ocean Centre, 5 Canton Rd.
Tsimshatsui, Kowloon
Hong Kong
Tel: (852) 2737-1600
Fax: (852) 2736-9960

National Semiconductor Japan Ltd.
Tel: 81-043-299-2309
Fax: 81-043-299-2408

r d a n a r T L T F d - L C E x e H r e w o P w o L 523001