

TLP521GB, TLP521-2GB, TLP521-4GB
 TLP521, TLP521-2, TLP521-4



**HIGH DENSITY MOUNTING
 PHOTOTRANSISTOR
 OPTICALLY COUPLED ISOLATORS**

APPROVALS

- UL recognised, File No. E91231

DESCRIPTION

The TLP521, TLP521-2, TLP521-4 series of optically coupled isolators consist of infrared light emitting diodes and NPN silicon photo transistors in space efficient dual in line plastic packages.

FEATURES

- Options :-
 10mm lead spread - add G after part no.
 Surface mount - add SM after part no.
 Tape&reel - add SMT&R after part no.
- High Current Transfer Ratio (50% min)
- High Isolation Voltage (5.3kV_{RMS}, 7.5kV_{PK})
- High BV_{CEO} (55Vmin)
- All electrical parameters 100% tested
- Custom electrical selections available

APPLICATIONS

- Computer terminals
- Industrial systems controllers
- Measuring instruments
- Signal transmission between systems of different potentials and impedances

TLP521

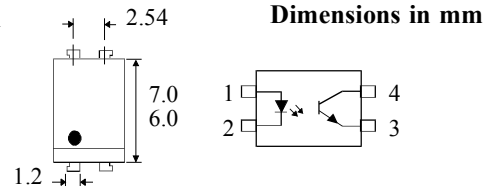

TLP521-2

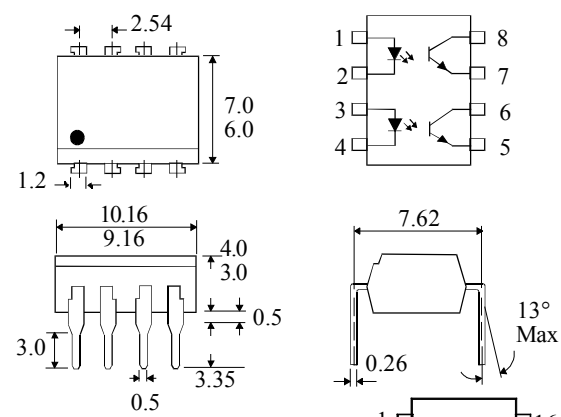

TLP521-4

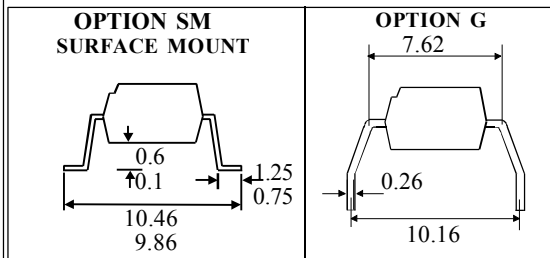
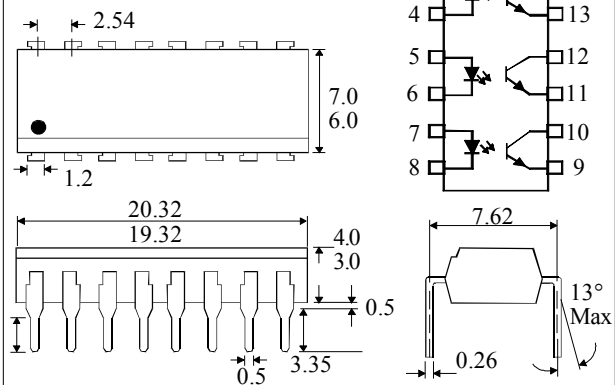

ISOCOM COMPONENTS LTD
 Unit 25B, Park View Road West,
 Park View Industrial Estate, Brenda Road
 Hartlepool, Cleveland, TS25 1YD
 Tel: (01429) 863609 Fax :(01429) 863581

ISOCOM INC
 1024 S. Greenville Ave, Suite 240,
 Allen, TX 75002 USA
 Tel: (214)495-0755 Fax: (214)495-0901
 e-mail info@isocom.com
 http://www.isocom.com

ABSOLUTE MAXIMUM RATINGS
(25°C unless otherwise specified)

Storage Temperature _____ -55°C to + 125°C
 Operating Temperature _____ -55°C to + 100°C
 Lead Soldering Temperature
 (1/16 inch (1.6mm) from case for 10 secs) 260°C

INPUT DIODE

Forward Current _____ 50mA
 Reverse Voltage _____ 5V
 Power Dissipation _____ 70mW

OUTPUT TRANSISTOR

Collector-emitter Voltage BV_{CEO} _____ 55V
 Emitter-collector Voltage BV_{ECO} _____ 6V
 Power Dissipation _____ 150mW

POWER DISSIPATION

Total Power Dissipation _____ 200mW
 (derate linearly 2.67mW/°C above 25°C)

ELECTRICAL CHARACTERISTICS ($T_A = 25^\circ\text{C}$ Unless otherwise noted)

PARAMETER		MIN	TYP	MAX	UNITS	TEST CONDITION
Input	Forward Voltage (V_F)	1.0	1.15	1.3	V	$I_F = 10\text{mA}$
	Reverse Voltage (V_R)	5			V	$I_R = 10\mu\text{A}$
	Reverse Current (I_R)			10	μA	$V_R = 5\text{V}$
Output	Collector-emitter Breakdown (BV_{CEO}) (Note 2)	55			V	$I_C = 0.5\text{mA}$
	Emitter-collector Breakdown (BV_{ECO})	6			V	$I_E = 100\mu\text{A}$
	Collector-emitter Dark Current (I_{CEO})			100	nA	$V_{CE} = 24\text{V}$
Coupled	Current Transfer Ratio (CTR) (Note 2) TLP521, TLP521-2, TLP521-4	50		600	%	$5\text{mA } I_F, 5\text{V } V_{CE}$
	CTR selection available BL	200		600	%	
	GB	100		600	%	
	GB	30			%	$1\text{mA } I_F, 0.4\text{V } V_{CE}$
	Collector-emitter Saturation Voltage $V_{CE(SAT)}$ -GB			0.4	V	$8\text{mA } I_F, 2.4\text{mA } I_C$
				0.4	V	$1\text{mA } I_F, 0.2\text{mA } I_C$
	Input to Output Isolation Voltage V_{ISO}	5300 7500			V_{RMS} V_{PK}	See note 1 See note 1
	Input-output Isolation Resistance R_{ISO}	5×10^{10}			Ω	$V_{IO} = 500\text{V}$ (note 1)
	Rise Time tr		2		μs	$V_{CC} = 10\text{V}$,
	Fall Time tf		3		μs	$I_C = 2\text{mA}, R_L = 100\Omega$
Turn-on Time ton		3		μs		
Turn-off Time toff		3		μs		

Note 1 Measured with input leads shorted together and output leads shorted together.

Note 2 Special Selections are available on request. Please consult the factory.

Collector Power Dissipation vs. Ambient Temperature

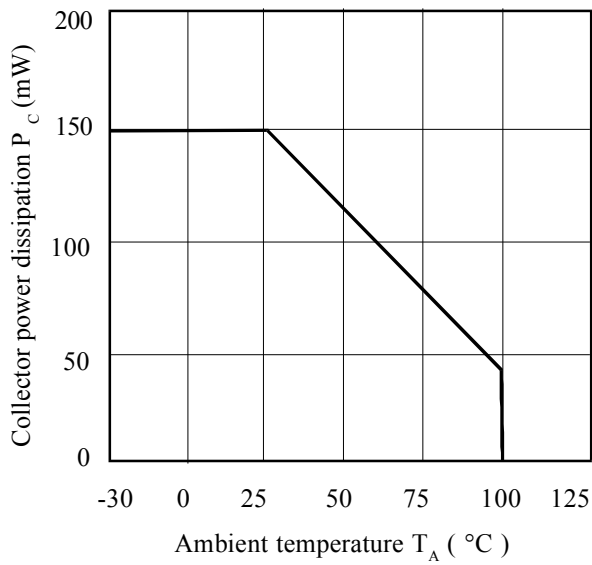

Collector Current vs. Low Collector-emitter Voltage

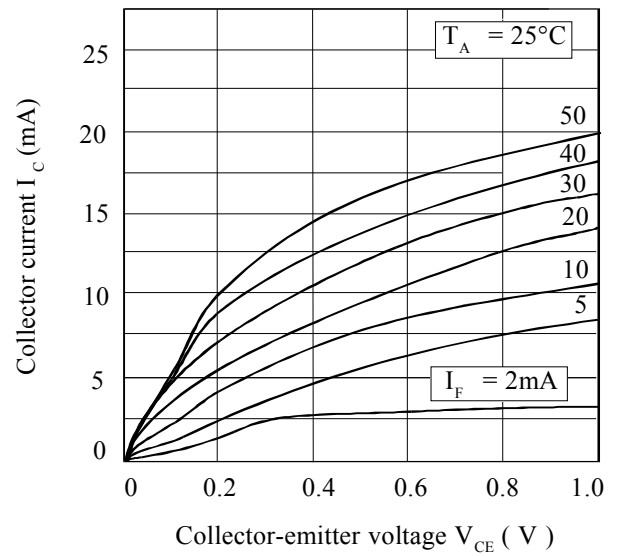

Forward Current vs. Ambient Temperature

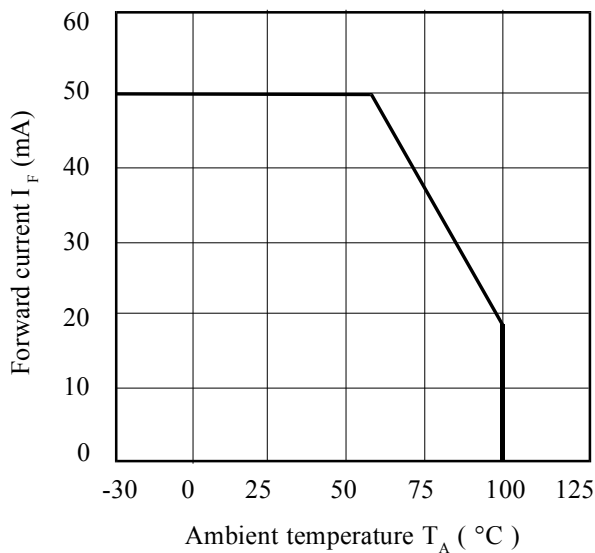

Collector Current vs. Collector-emitter Voltage

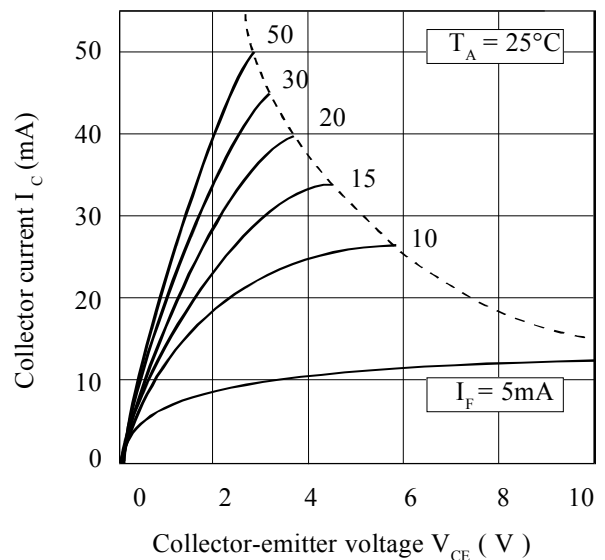

Collector-emitter Saturation Voltage vs. Ambient Temperature

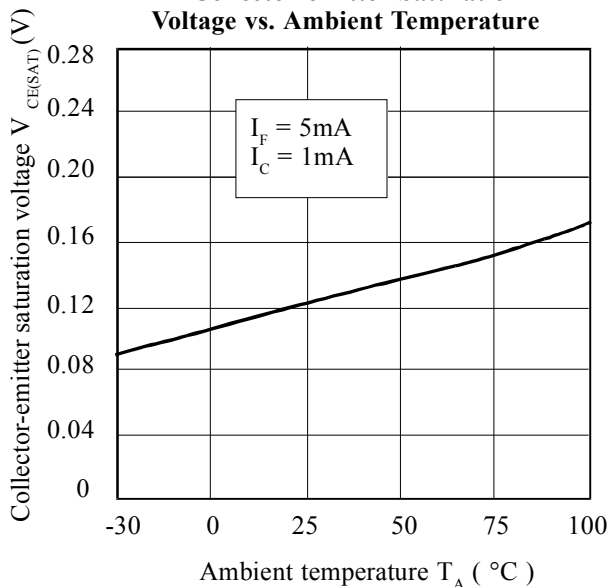

Current Transfer Ratio vs. Forward Current

