

TMS28F210 65536 BY 16-BIT FLASH MEMORY

SMJS210D – DECEMBER 1992 – REVISED AUGUST 1997

- Organization . . . 65536 by 16-Bits
- Pin Compatible With Existing 1-Megabit EPROMs
- All Inputs/Outputs TTL Compatible
- V_{CC} Tolerance $\pm 10\%$
- Maximum Access/Minimum Cycle Time
 - '28F210-10 100 ns
 - '28F210-12 120 ns
 - '28F210-15 150 ns
 - '28F210-17 170 ns
- Industry-Standard Programming Algorithm
- PEP4 Version Available With 168-Hour Burn-In and Choice of Operating Temperature Ranges
- 10000 and 1000 Program/Erase Cycles
- Latchup Immunity of 250 mA on All Input and Output Lines
- Low Power Dissipation ($V_{CC} = 5.5$ V)
 - Active Write . . . 55 mW
 - Active Read . . . 165 mW
 - Electrical Erase . . . 82.5 mW
 - Standby . . . 0.55 mW (CMOS-Input Levels)
- Automotive Temperature Range
 - -40°C to 125°C

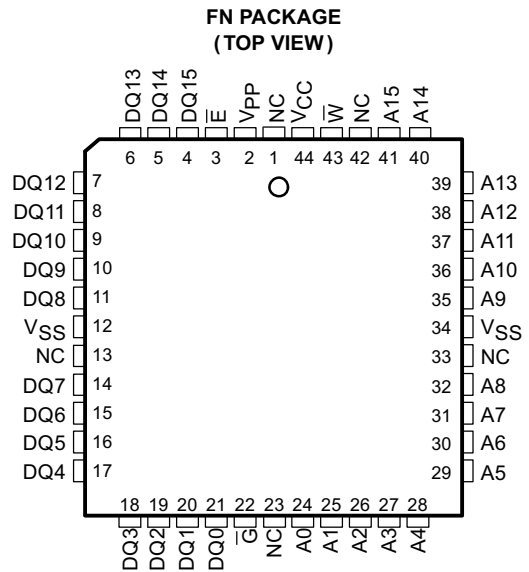

description

The TMS28F210 is a 65536 by 16-bit (1048 576-bit), programmable read-only memory that can be electrically bulk-erased and reprogrammed. It is available in 10000- and 1000-program/erase-endurance-cycle versions.

The TMS28F210 flash memory is offered in a 44-lead plastic leaded chip carrier package using 1,25 mm (50-mil) lead spacing (FN suffix), and a 40-lead thin small-outline package (DBW suffix).

The TMS28F210 is characterized for operation in temperature ranges of 0°C to 70°C , -40°C to 85°C , and -40°C to 125°C .



Please be aware that an important notice concerning availability, standard warranty, and use in critical applications of Texas Instruments semiconductor products and disclaimers thereto appears at the end of this data sheet.

PRODUCTION DATA information is current as of publication date. Products conform to specifications per the terms of Texas Instruments standard warranty. Production processing does not necessarily include testing of all parameters.

 **TEXAS
INSTRUMENTS**

POST OFFICE BOX 1443 • HOUSTON, TEXAS 77251-1443

Copyright © 1997, Texas Instruments Incorporated

TMS28F210
65536 BY 16-BIT
FLASH MEMORY

SMJS210D – DECEMBER 1992 – REVISED AUGUST 1997

DBW PACKAGE
(TOP VIEW)



PIN NOMENCLATURE

A0–A15	Address Inputs
\overline{E}	Chip Enable
\overline{G}	Output Enable
V _{SS}	Ground
NC	No Connection
\overline{W}	Program
DQ0–DQ15	Inputs (programming)/Outputs
V _{CC}	5-V Supply
V _{PP}	12-V Power Supply†

† Only in program mode



POST OFFICE BOX 1443 • HOUSTON, TEXAS 77251-1443

TMS28F210
65 536 BY 16-BIT
FLASH MEMORY

SMJS210D – DECEMBER 1992 – REVISED AUGUST 1997

device symbol nomenclature

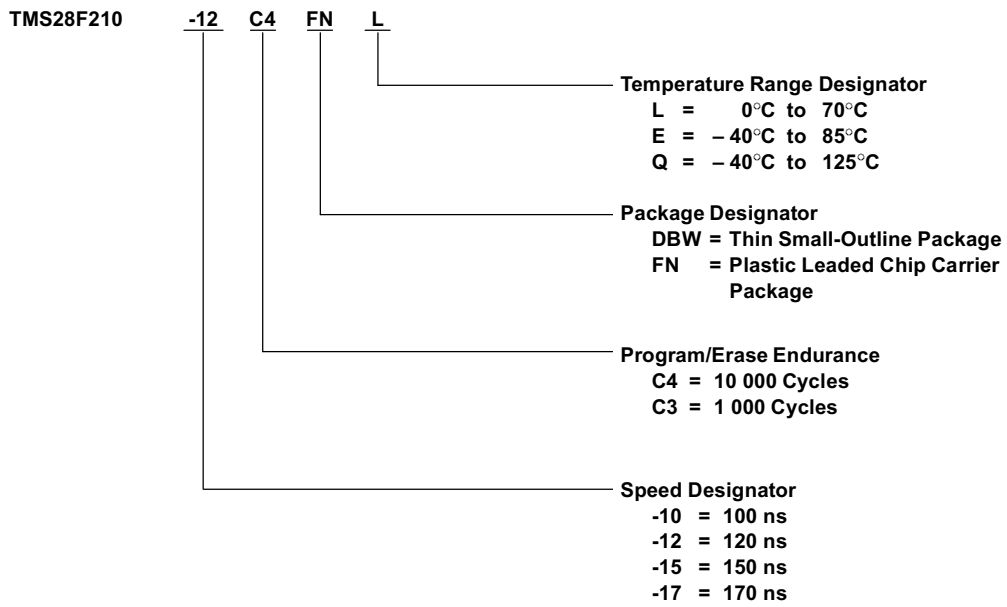

TMS28F210
65 536 BY 16-BIT
FLASH MEMORY

SMJS210D – DECEMBER 1992 – REVISED AUGUST 1997

logic symbol†

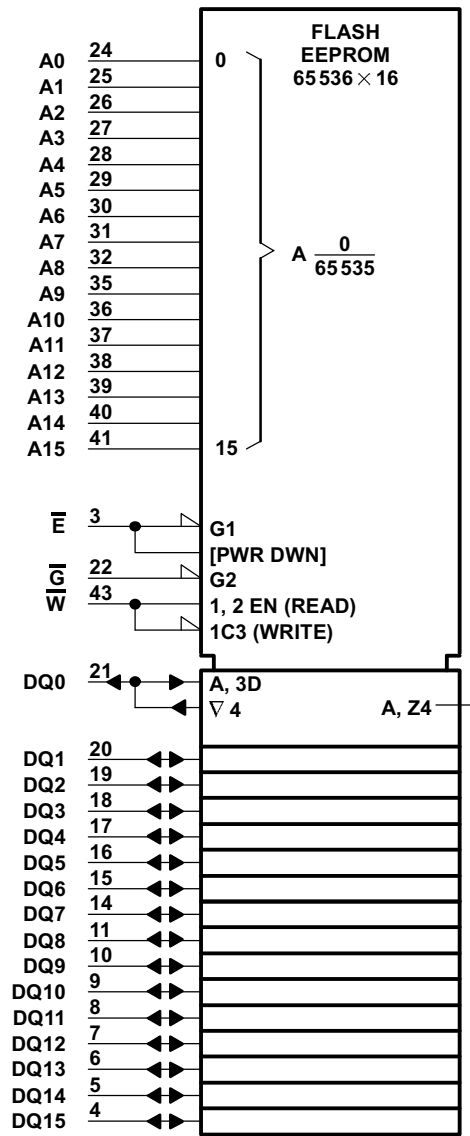

† This symbol is in accordance with ANSI/IEEE Std 91-1984 and IEC Publication 617-12.
 Pin numbers shown are for the FN package.

TMS28F210
65536 BY 16-BIT
FLASH MEMORY

SMJS210D – DECEMBER 1992 – REVISED AUGUST 1997

logic symbol† (continued)

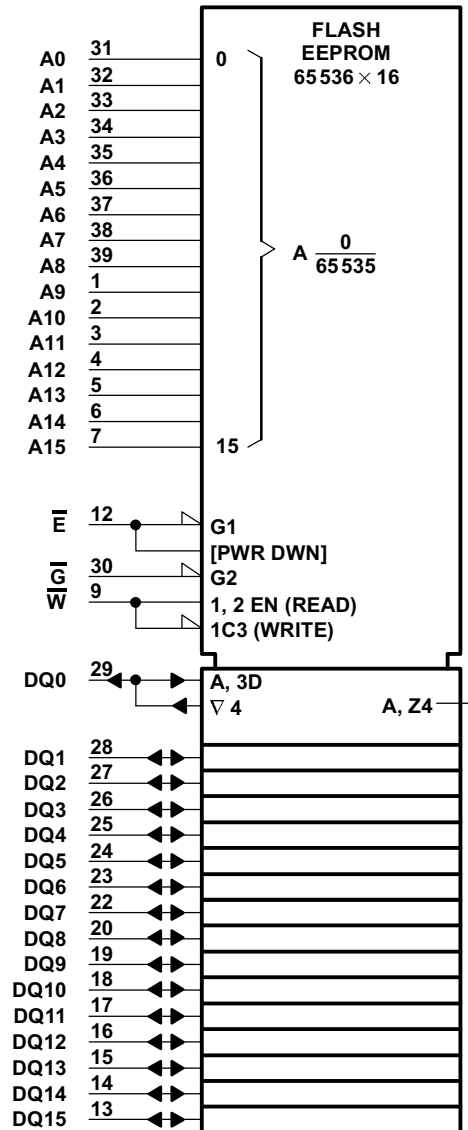

† This symbol is in accordance with ANSI/IEEE Std 91-1984 and IEC Publication 617-12.
 Pin numbers shown are for the DBW package.

TMS28F210
65536 BY 16-BIT
FLASH MEMORY

SMJS210D – DECEMBER 1992 – REVISED AUGUST 1997

functional block diagram

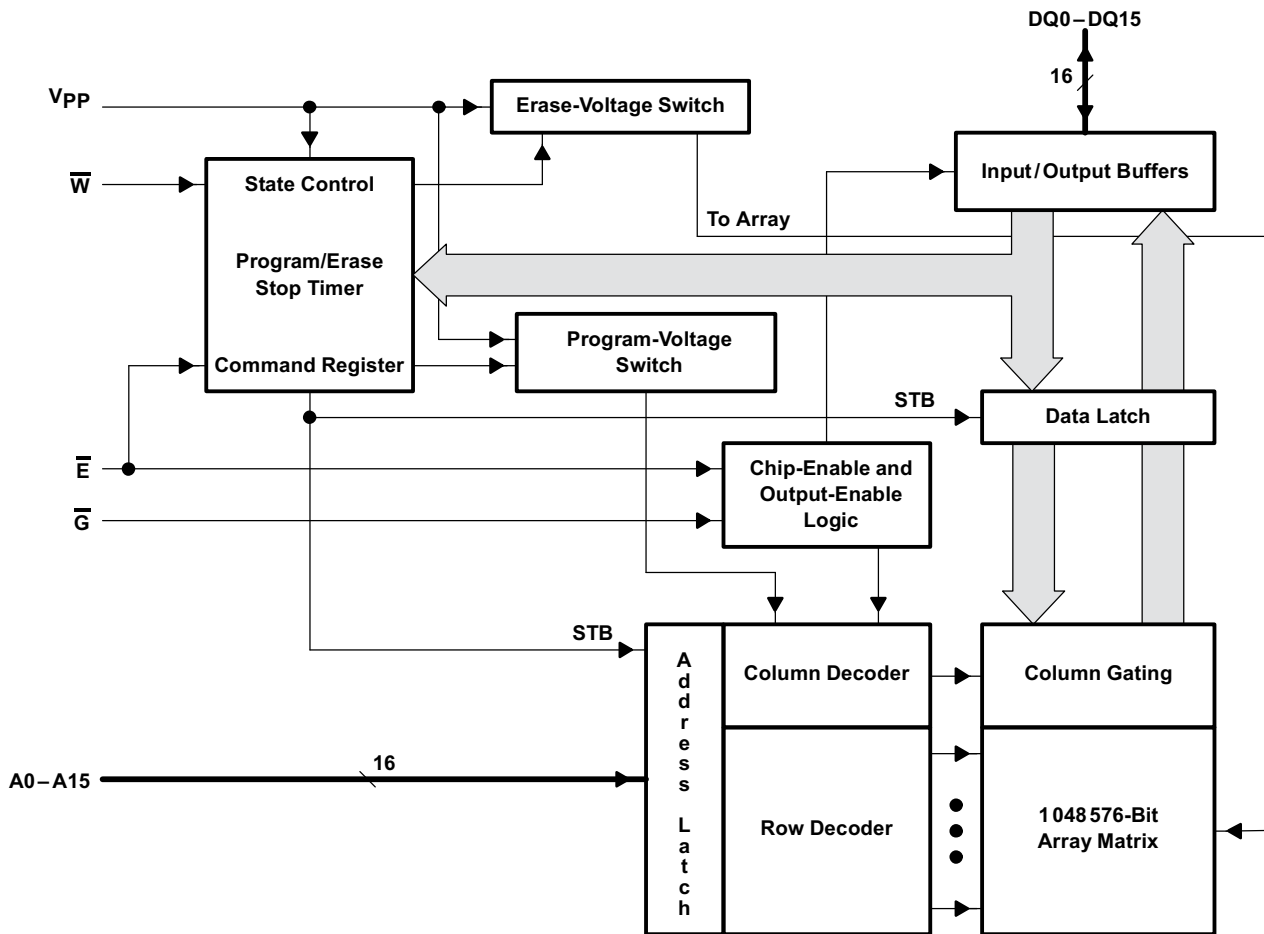

operation

Modes of operation are defined in Table 1.

Table 1. Operation Modes†‡

MODE		FUNCTION							
		DBW PACKAGE	Vpp§	\bar{E}	\bar{G}	A0	A9	\bar{W}	DQ0–DQ15
		FN PACKAGE	11	12	30	31	1	9	13–20, 22–29
			2	3	22	24	35	43	4–11, 14–21
Read	Read	VpPL	V _{IL}	V _{IL}	X	X	V _{IH}	Data Out	
	Output Disable	VpPL	V _{IL}	V _{IH}	X	X	V _{IH}	Hi-Z	
	Standby and Write Inhibit	VpPL	V _{IH}	X	X	X	X	Hi-Z	
	Algorithm-Selection Mode	VpPL	V _{IL}	V _{IL}	V _{IL}	V _{ID}	V _{IH}	Mfr. Equivalent Code 0097h Device Equivalent Code 00E5h	
Read/ Write	Read	VpPH	V _{IL}	V _{IL}	X	X	V _{IH}	Data Out	
	Output Disable	VpPH	V _{IL}	V _{IH}	X	X	V _{IH}	Hi-Z	
	Standby and Write Inhibit	VpPH	V _{IH}	X	X	X	X	Hi-Z	
	Write	VpPH	V _{IL}	V _{IH}	X	X	V _{IL}	Data In	

† See the recommended operating conditions table.

‡ X can be V_{IL} or V_{IH}.

§ VpPL ≤ V_{CC} + 2 V; VpPH is the programming voltage specified for the device.

read/output disable

When the outputs of two or more TMS28F210s are connected in parallel on the same bus, the output of any particular device in the circuit can be read with no interference from the competing outputs of other devices. To read the output of the TMS28F210, a low-level signal is applied to the \bar{E} and \bar{G} pins. All other devices in the circuit should have their outputs disabled by applying a high-level signal to one of these pins.

standby and write inhibit

Active I_{CC} current can be reduced from 50 mA to 1 mA by applying a high TTL level on \bar{E} or reduced to 100 μA with a high CMOS level on \bar{E} . In this mode, all outputs are in the high-impedance state. The TMS28F210 draws active current when it is deselected during programming, erasure, or program/erase verification. It continues to draw active current until the operation is terminated.

algorithm-selection mode

The algorithm-selection mode provides access to a binary code that identifies the correct programming and erase algorithms. This mode is activated when A9 is forced to V_{ID}. Two identifier bytes are accessed by toggling A0. All other addresses must be held low. A0 low selects the manufacturer-equivalent code 0097h, and A0 high selects the device-equivalent code 00E5h, as shown in Table 2.

Table 2. Algorithm-Selection Modes¶

IDENTIFIER	PINS#									
	A0	DQ7	DQ6	DQ5	DQ4	DQ3	DQ2	DQ1	DQ0	HEX
Manufacturer-Equivalent Code	V _{IL}	1	0	0	1	0	1	1	1	0097
Device-Equivalent Code	V _{IH}	1	1	1	0	0	1	0	1	00E5

¶ $\bar{E} = \bar{G} = A1–A8 = A10–A15 = V_{IL}$, A9 = V_{ID}, Vpp = VpPL

D8–D15 are not shown in the table because the upper eight data bits read 0.

TMS28F210 65536 BY 16-BIT FLASH MEMORY

SMJS210D – DECEMBER 1992 – REVISED AUGUST 1997

programming and erasure

In the erased state, all bits are at a logic 1. Before erasing the device, all memory bits must be programmed to a logic 0. Afterwards, the entire chip is erased. At this point, the bits, now logic 1s, can be programmed accordingly. Refer to the Fastwrite and Fasterase algorithms for further detail.

command register

The command register controls the program and erase functions of the TMS28F210. The algorithm-selection mode can be activated using the command register in addition to the above method. When V_{PP} is high, the contents of the command register and the function being performed can be changed. The command register is written to when \bar{E} is low and \bar{W} is pulsed low. The address is latched on the leading edge of the pulse, while the data is latched on the trailing edge. Accidental programming or erasure is minimized because two commands must be executed to invoke either operation. The command register is inhibited when V_{CC} is below the erase/write lockout voltage, V_{LKO} .

power supply considerations

Each device should have a 0.1- μ F ceramic capacitor connected between V_{CC} and V_{SS} to suppress circuit noise. Changes in current drain on V_{PP} requires it to have a bypass capacitor as well. Printed circuit traces for both power supplies should be appropriate to handle the current demand.

command definitions

See Table 3 for command definitions.

Table 3. Command Definitions

COMMAND	REQUIRED BUS CYCLES	FIRST BUS CYCLE			SECOND BUS CYCLE		
		OPERATION†	ADDRESS	DATA	OPERATION†	ADDRESS	DATA
Read	1	Write	X	0000h	Read	RA	RD
Algorithm-Selection Mode	3	Write	X	0090h	Read	0000 0001	0097h 00E5h
Set-Up-Erase/Erase	2	Write	X	0020h	Write	X	20h
Erase Verify	2	Write	EA	00A0h	Read	X	EVD
Set-Up-Program/Program	2	Write	X	0040h	Write	PA	PD
Program Verify	2	Write	X	00C0h	Read	X	PVD
Reset	2	Write	X	00FFh	Write	X	00FFh

† Modes of operation are defined in Table 1.

Legend:

- EA Address of memory location to be read during erase verify
- RA Address of memory location to be read
- PA Address of memory location to be programmed. Address is latched on the falling edge of \bar{W} .
- RD Data read from location RA during the read operation
- EVD Data read from location EA during erase verify
- PD Data to be programmed at location PA. Data is latched on the rising edge of \bar{W} .
- PVD Data read from location PA during program verify
- X Don't care.

read command

Memory contents can be accessed while V_{PP} is high or low. When V_{PP} is high, writing 0000h into the command register invokes the read operation. When the device is powered up, the default contents of the command register are 0000h and the read operation is enabled. The read operation remains enabled until a different valid command is written to the command register.



algorithm-selection-mode command

The algorithm-selection mode is activated by writing 0090h into the command register. The manufacturer equivalent code (0097h) is identified by the value read from address location 0000h, and the device equivalent code (00E5h) is identified by the value read from address location 0001h.

set-up-program/program commands

The programming algorithm initiates with $\bar{E} = V_{IL}$, $\bar{W} = V_{IL}$, $\bar{G} = V_{IH}$, $V_{PP} = V_{PPH}$, and $V_{CC} = 5\text{ V}$. To enter the programming mode, write the set-up-program command, 0040h, into the command register. The programming operation is invoked by the next write-enable pulse. Addresses are latched internally on the falling edge of \bar{W} , and data is latched internally on the rising edge of \bar{W} . The programming operation begins on the rising edge of \bar{W} and ends on the rising edge of the next \bar{W} pulse. The program operation requires 10 μs for completion before the program-verify command, 00C0h, can be loaded.

Maximum program timing is controlled by the internal stop timer. When the stop timer terminates the program operation, the device enters an inactive state and remains inactive until a command is received.

program-verify command

The TMS28F210 can be programmed sequentially or randomly because it is programmed one word at a time. Each word must be verified after it is programmed. The program-verify operation prepares the device to verify the most recently programmed word. To invoke the program-verify operation, 00C0h must be written into the command register. The program-verify operation ends on the rising edge of \bar{W} .

While verifying a word, the TMS28F210 applies an internal margin voltage to the designated word. If the true data and programmed data match, programming continues to the next designated word location; otherwise, the word must be reprogrammed. Figure 1 shows how commands and bus operations are combined for word programming.

set-up-erase/erase commands

The erase algorithm initiates with $\bar{E} = V_{IL}$, $\bar{W} = V_{IL}$, $\bar{G} = V_{IH}$, $V_{PP} = V_{PPH}$, and $V_{CC} = 5\text{ V}$. To enter the erase mode, write the set-up-erase command, 0020h, into the command register. After the TMS28F210 is in the erase mode, writing a second erase command, 0020h, into the command register invokes the erase operation. The erase operation begins on the rising edge of \bar{W} and ends on the rising edge of the next \bar{W} . The erase operation requires 10 ms to complete before the erase-verify command, 00A0h, can be loaded.

Maximum erase timing is controlled by the internal stop timer. When the stop timer terminates the erase operation, the device enters an inactive state and remains inactive until a command is received.

erase-verify command

All words must be verified following an erase operation. After the erase operation is complete, an erased word can be verified by writing the erase-verify command, 00A0h, into the command register. This command causes the device to exit the erase mode on the rising edge of \bar{W} . The address of the word to be verified is latched on the falling edge of \bar{W} . The erase-verify operation remains enabled until a command is written to the command register.

TMS28F210
65 536 BY 16-BIT
FLASH MEMORY

SMJS210D – DECEMBER 1992 – REVISED AUGUST 1997

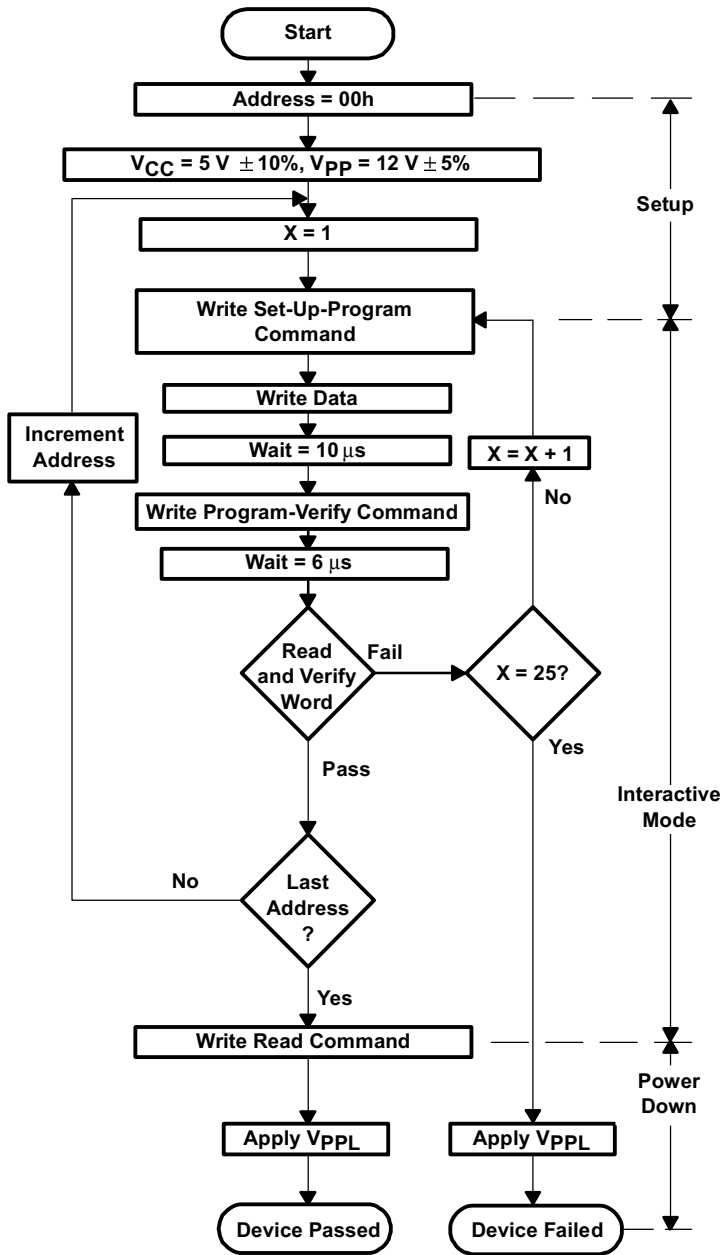

Bus Operation	Command	Comments
Initialize Address		
Standby		Wait for V _{PP} to ramp to V _{PPH} (see Note A) Initialize pulse count
Write	Set-Up-Program	Data = 0040h
Write	Write Data	Valid address / data
Standby		Wait = 10 μs
Write	Program-Verify	Data = 00C0h; ends program operation
Standby		Wait = 6 μs
Read		Read word to verify programming; compare output to expected output
Write	Read	Data = 0000h; resets register for read operations
Standby		Wait for V _{PP} to ramp to V _{PLL} (see Note B)

NOTES: A. Refer to the recommended operating conditions for the value of V_{PPH}
 B. Refer to the recommended operating conditions for the value of V_{PLL}

Figure 1. Programming Flowchart: Fastwrite Algorithm



erase-verify command (continued)

To determine whether or not all the words have been erased, the TMS28F210 applies a margin voltage to each word. If FFFFh is read from the word, all bits in the designated word have been erased. The erase-verify operation continues until all of the words have been verified. If FFFFh is not read from a word, an additional erase operation needs to be executed. Figure 2 shows the combination of commands and bus operations for electrically erasing the TMS28F210.

reset command

To reset the TMS28F210 after a set-up-erase operation or a set-up-program operation without changing the contents in memory, write 00FFh into the command register two consecutive times. After executing the reset command, the device defaults to the read mode.

Fastwrite algorithm

The TMS28F210 is programmed using the Texas Instruments fastwrite algorithm previously shown in Figure 1. This algorithm programs in a nominal time of two seconds.

Fasterase algorithm

The TMS28F210 is erased using the Texas Instruments fasterase algorithm shown in Figure 2. The memory array needs to be programmed completely (using the fastwrite algorithm) before erasure begins. Erasure typically occurs in one second.

parallel erasure

To reduce total erase time, several devices can be erased in parallel. Since each flash memory can erase at a different rate, every device must be verified separately after each erase pulse. After a given device has been erased successfully, the erase command should not be issued to this device again. All devices that complete erasure should be masked until the parallel erasure process is finished shown in Figure 3.

Examples of how to mask a device during parallel erase include driving the \bar{E} pin high, writing the read command (0000h) to the device when the others receive a set-up-erase or erase command, or disconnecting it from all electrical signals with relays or other types of switches.

TMS28F210
65536 BY 16-BIT
FLASH MEMORY

SMJS210D – DECEMBER 1992 – REVISED AUGUST 1997

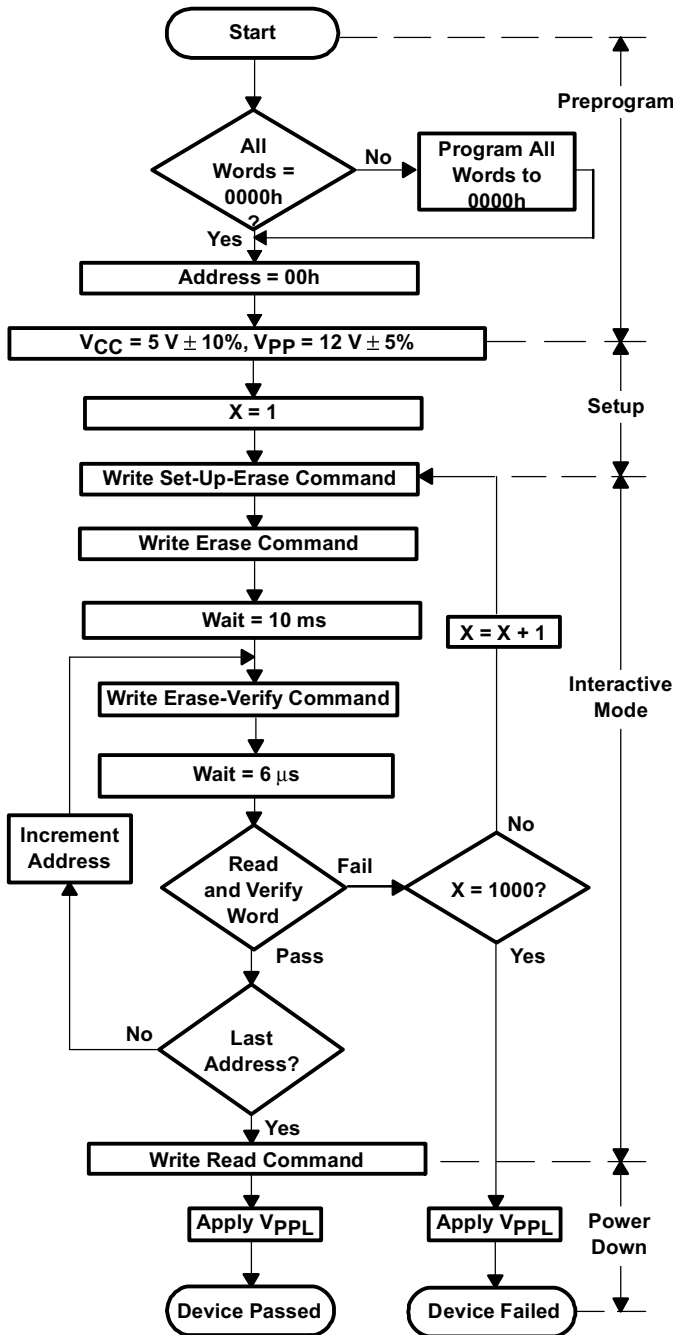

Bus Operation	Command	Comments
		Entire memory must = 0000h before erasure Use Fastwrite programming algorithm
		Initialize addresses
Standby		Wait for V _{pp} to ramp to V _{ppH} (see Note A)
		Initialize pulse count
Write	Set-Up-Erase	Data = 0020h
Write	Erase	Data = 0020h
Standby		Wait = 10 ms
Write	Erase Verify	Addr = Word to verify; data = 00A0h; ends the erase operation
Standby		Wait = 6 μs
Read		Read word to verify erasure; compare output to FFFFh
Write	Read	Data = 0000h; resets register for read operations
Standby		Wait for V _{pp} to ramp to V _{ppL} (see Note B)

NOTES: A. Refer to the recommended operating conditions for the value of V_{ppH}
 B. Refer to the recommended operating conditions for the value of V_{ppL}

Figure 2. Flash-Erase Flowchart: Fasterase Algorithm



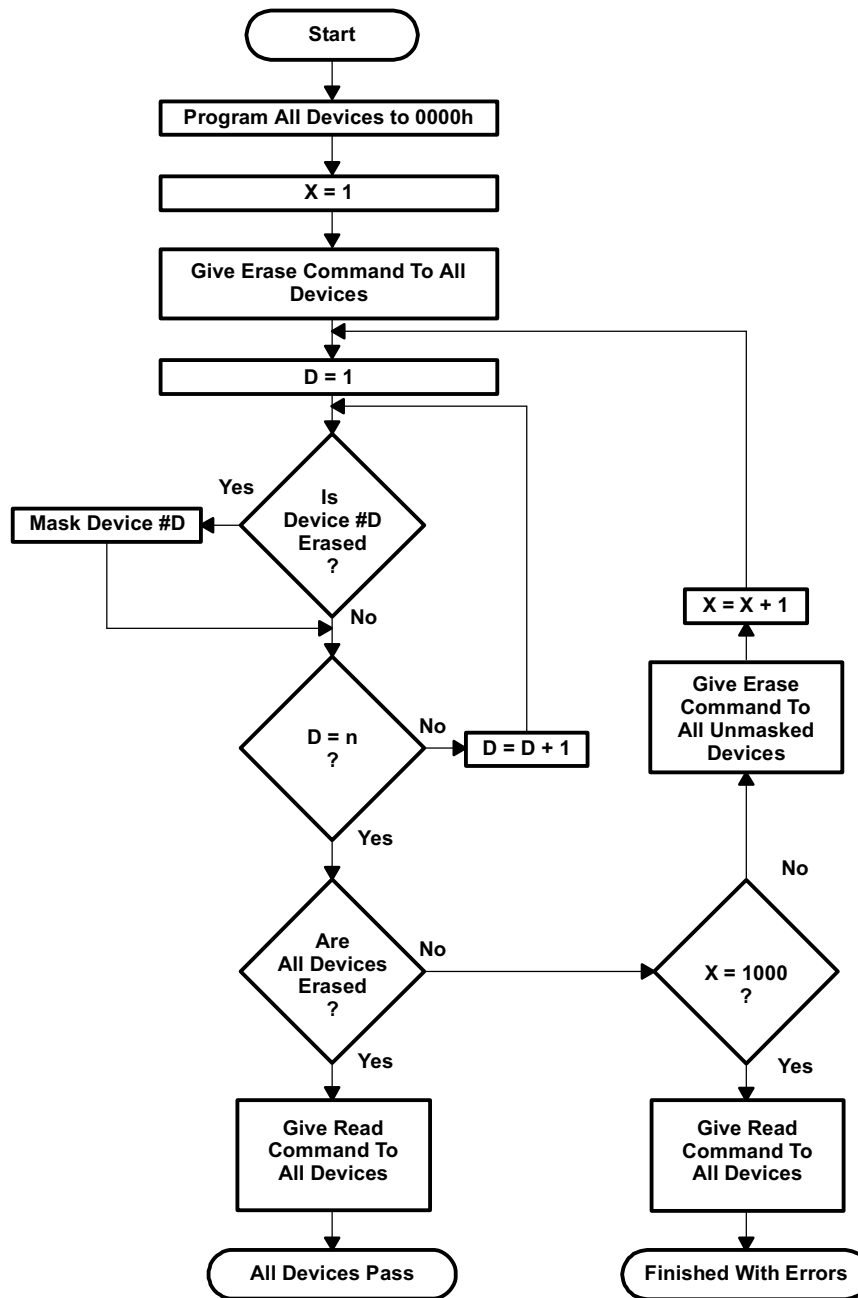

NOTE: n = number of devices being erased

Figure 3. Parallel-Erase Flow Diagram

TMS28F210
65536 BY 16-BIT
FLASH MEMORY

SMJS210D – DECEMBER 1992 – REVISED AUGUST 1997

electrical characteristics over recommended ranges of supply voltage and operating free-air temperature

PARAMETER		TEST CONDITIONS	MIN	MAX	UNIT
V _{OH}	High-level output voltage	TTL	2.4		V
		CMOS	V _{CC} – 0.4		
V _{OL}	Low-level output voltage	TTL	0.45		V
		CMOS	0.1		
I _I	Input current (leakage)	All except A9	±1		μA
		A9	±200		
I _O	Output current (leakage)	V _O = 0 V to V _{CC}	±10		μA
I _{ID}	A9 algorithm-selection-mode current	A9 = V _{ID} max	±200		μA
I _{PP1}	V _{PP} supply current (read/standby)	V _{PP} = V _{PPH} , Read mode	200		μA
		V _{PP} = V _{PPL}	±10		
I _{PP2}	V _{PP} supply current (during program pulse) (see Note 4)	V _{PP} = V _{PPH}	50		mA
I _{PP3}	V _{PP} supply current (during flash erase) (see Note 4)	V _{PP} = V _{PPH}	50		mA
I _{PP4}	V _{PP} supply current (during program/erase verify) (see Note 4)	V _{PP} = V _{PPH}	5		mA
I _{CCS}	V _{CC} supply current (standby)	TTL-input level	1		mA
		CMOS-input level	100		
I _{CC1}	V _{CC} supply current (active read)	V _{CC} = 5.5 V, $\bar{E} = V_{IH}$, I _{OUT} = 0 mA, f = 6 MHz	50		mA
I _{CC2}	V _{CC} average supply current (active write) (see Note 4)	V _{CC} = 5.5 V, $\bar{E} = V_{IL}$, Programming in progress	10		mA
I _{CC3}	V _{CC} average supply current (flash erase) (see Note 4)	V _{CC} = 5.5 V, $\bar{E} = V_{IL}$, Erasure in progress	15		mA
I _{CC4}	V _{CC} average supply current (program/erase verify) (see Note 4)	V _{CC} = 5.5 V, $\bar{E} = V_{IL}$, V _{PP} = V _{PPH} , Program/erase verify in progress	15		mA

NOTE 4: Characterization data available

capacitance over recommended ranges of supply voltage and operating free-air temperature, f = 1 MHz†

PARAMETER		TEST CONDITIONS	MIN	MAX	UNIT
C _I	Input capacitance	V _I = 0 V, f = 1 MHz	6		pF
C _O	Output capacitance	V _O = 0 V, f = 1 MHz	12		pF

† Capacitance measurements are made on sample basis only.



TMS28F210
65536 BY 16-BIT
FLASH MEMORY

SMJS210D – DECEMBER 1992 – REVISED AUGUST 1997

switching characteristics over recommended ranges of supply voltage and operating free-air temperature

PARAMETERS	TEST CONDITIONS	ALTERNATE SYMBOL	'28F210-10		'28F210-12		'28F210-15		'28F210-17		UNIT
			MIN	MAX	MIN	MAX	MIN	MAX	MIN	MAX	
$t_{a(A)}$ Access time from address	$C_L = 100$ pF, 1 Series 74 TTL load, Input $t_r \leq 20$ ns, Input $t_f \leq 20$ ns	t_{AVQV}		100		120		150		170	ns
$t_{a(E)}$ Access time from \bar{E}		t_{ELQV}		100		120		150		170	ns
$t_{en(G)}$ Access time from \bar{G}		t_{GLQV}		45		50		55		60	ns
$t_{c(R)}$ Cycle time, read		t_{AVAV}	100		120		150		170		ns
$t_{d(E)}$ Delay time, chip enable low to low-Z output		t_{ELQX}	0		0		0		0		ns
$t_{d(G)}$ Delay time, \bar{G} low to low-Z output		t_{GLQX}	0		0		0		0		ns
$t_{dis(E)}$ Chip disable to hi-Z output		t_{EHQZ}	0	55	0	55	0	55	0	55	ns
$t_{dis(G)}$ Disable time, output enable to hi-Z output		t_{GHQZ}	0	30	0	30	0	35	0	35	ns
$t_h(D)$ Hold time, data valid from address, \bar{E} , or \bar{G} †		t_{AXQX}	0		0		0		0		ns
$t_{rec(W)}$ Write recovery time before read		t_{WHGL}	6		6		6		6		μ s

† Whichever occurs first



timing requirements—write/erase/program operations

	ALTERNATE SYMBOL	'28F210-10			'28F210-12			UNIT	
		MIN	NOM	MAX	MIN	NOM	MAX		
$t_{c(W)}$	Cycle time, write using \overline{W}	t_{AVAV}			120			ns	
$t_{c(W)PR}$	Cycle time, programming operation	t_{WHWH1}			10			μ s	
$t_{c(W)ER}$	Cycle time, erase operation	t_{WHWH2}			9.5	10	9.5	10	ms
$t_h(A)$	Hold time, address	t_{WLAX}			60			ns	
$t_h(E)$	Hold time, \overline{E}	t_{WHEH}			0			ns	
$t_h(WHD)$	Hold time, data valid after \overline{W} high	t_{WHDX}			10			ns	
$t_{su(A)}$	Setup time, address	t_{AVWL}			0			ns	
$t_{su(D)}$	Setup time, data	t_{DVWH}			50			ns	
$t_{su(E)}$	Setup time, \overline{E} before \overline{W}	t_{ELWL}			20			ns	
$t_{su(EHVPP)}$	Setup time, \overline{E} high to V_{pp} ramp	t_{EHVP}			100			ns	
$t_{su(VPEL)}$	Setup time, V_{pp} to \overline{E} low	t_{VPEL}			1			μ s	
$t_{rec(W)}$	Recovery time, \overline{W} before read	t_{WHGL}			6			μ s	
$t_{rec(R)}$	Recovery time, read before \overline{W}	t_{GHWL}			0			μ s	
$t_w(W)$	Pulse duration, \overline{W}	t_{WLWH}			60			ns	
$t_w(WH)$	Pulse duration, \overline{W} high	t_{WHWL}			20			ns	
$t_r(VPP)$	Rise time, V_{pp}	t_{VPPR}			1			μ s	
$t_f(VPP)$	Fall time, V_{pp}	t_{VPPF}			1			μ s	

	ALTERNATE SYMBOL	'28F210-15			'28F210-17			UNIT	
		MIN	NOM	MAX	MIN	NOM	MAX		
$t_{c(W)}$	Cycle time, write using \overline{W}	t_{AVAV}			170			ns	
$t_{c(W)PR}$	Cycle time, programming operation	t_{WHWH1}			10			μ s	
$t_{c(W)ER}$	Cycle time, erase operation	t_{WHWH2}			9.5	10	9.5	10	ms
$t_h(A)$	Hold time, address	t_{WLAX}			70			ns	
$t_h(E)$	Hold time, \overline{E}	t_{WHEH}			0			ns	
$t_h(WHD)$	Hold time, data valid after \overline{W} high	t_{WHDX}			10			ns	
$t_{su(A)}$	Setup time, address	t_{AVWL}			0			ns	
$t_{su(D)}$	Setup time, data	t_{DVWH}			50			ns	
$t_{su(E)}$	Setup time, \overline{E} before \overline{W}	t_{ELWL}			20			ns	
$t_{su(EHVPP)}$	Setup time, \overline{E} high to V_{pp} ramp	t_{EHVP}			100			ns	
$t_{su(VPEL)}$	Setup time, V_{pp} to \overline{E} low	t_{VPEL}			1			μ s	
$t_{rec(W)}$	Recovery time, \overline{W} before read	t_{WHGL}			6			μ s	
$t_{rec(R)}$	Recovery time, read before \overline{W}	t_{GHWL}			0			μ s	
$t_w(W)$	Pulse duration, \overline{W}	t_{WLWH}			60			ns	
$t_w(WH)$	Pulse duration, \overline{W} high	t_{WHWL}			20			ns	
$t_r(VPP)$	Rise time, V_{pp}	t_{VPPR}			1			μ s	
$t_f(VPP)$	Fall time, V_{pp}	t_{VPPF}			1			μ s	

TMS28F210
65536 BY 16-BIT
FLASH MEMORY

SMJS210D – DECEMBER 1992 – REVISED AUGUST 1997

timing requirements—alternative \overline{E} -controlled writes

	ALTERNATE SYMBOL	'28F210-10		'28F210-12		'28F210-15		'28F210-17		UNIT
		MIN	MAX	MIN	MAX	MIN	MAX	MIN	MAX	
$t_{c(W)}$	Cycle time, write using \overline{E}	t_{AVAV}		100	120	150	170			ns
$t_{c(E)PR}$	Cycle time, programming operation	t_{EHEH}		10	10	10	10			μ s
$t_{h(EA)}$	Hold time, address	t_{ELAX}		75	80	80	90			ns
$t_{h(ED)}$	Hold time, data	t_{EHDX}		10	10	10	10			ns
$t_{h(W)}$	Hold time, \overline{W}	$t_{EHW H}$		0	0	0	0			ns
$t_{su(A)}$	Setup time, address	t_{AVEL}		0	0	0	0			ns
$t_{su(D)}$	Setup time, data	t_{DVEH}		50	50	50	50			ns
$t_{su(W)}$	Setup time, \overline{W} before \overline{E}	t_{WLEL}		0	0	0	0			ns
$t_{su(VPEL)}$	Setup time, V_{PP} to \overline{E} low	t_{VPEL}		1	1	1	1			μ s
$t_{rec(E)R}$	Recovery time, write using \overline{E} before read	t_{EHGL}		6	6	6	6			μ s
$t_{rec(E)W}$	Recovery time, read before write using \overline{E}	$t_{GH EL}$		0	0	0	0			μ s
$t_{W(E)}$	Pulse duration, write using \overline{E}	t_{ELEH}		70	70	70	80			ns
$t_{W(EH)}$	Pulse duration, write, \overline{E} high	t_{EHEL}		20	20	20	20			ns

PARAMETER MEASUREMENT INFORMATION

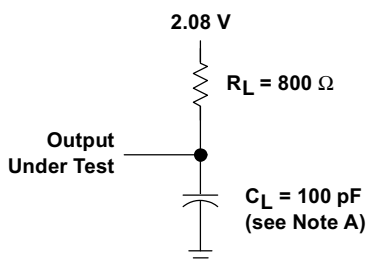

LOAD CIRCUIT

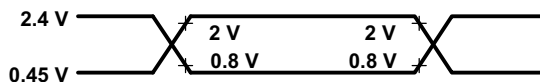

VOLTAGE WAVEFORMS

- NOTES: A. C_L includes probe and fixture capacitance.
 B. AC testing inputs are driven at 2.4 V for logic high and 0.45 V for logic low. Timing measurements are made at 2 V for logic high and 0.8 V for logic low on both inputs and outputs. Each device should have a 0.1- μ F ceramic capacitor connected between V_{CC} and V_{SS} as close as possible to the device pins.

Figure 4. Load Circuit and Voltage Waveforms



PARAMETER MEASUREMENT INFORMATION

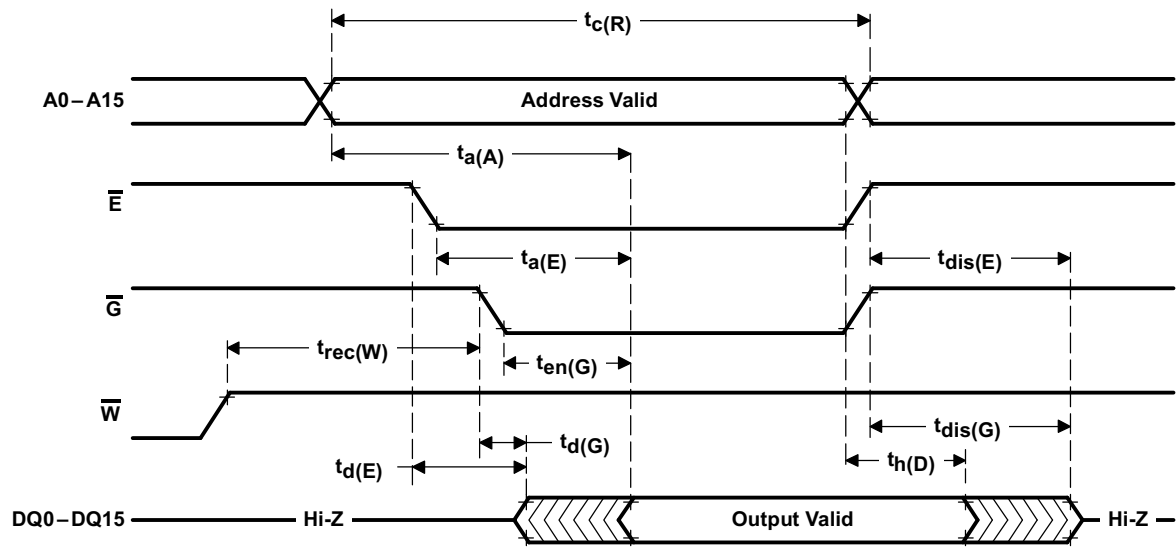

Figure 5. Read-Cycle Timing

TMS28F210
65536 BY 16-BIT
FLASH MEMORY

SMJS210D – DECEMBER 1992 – REVISED AUGUST 1997

PARAMETER MEASUREMENT INFORMATION

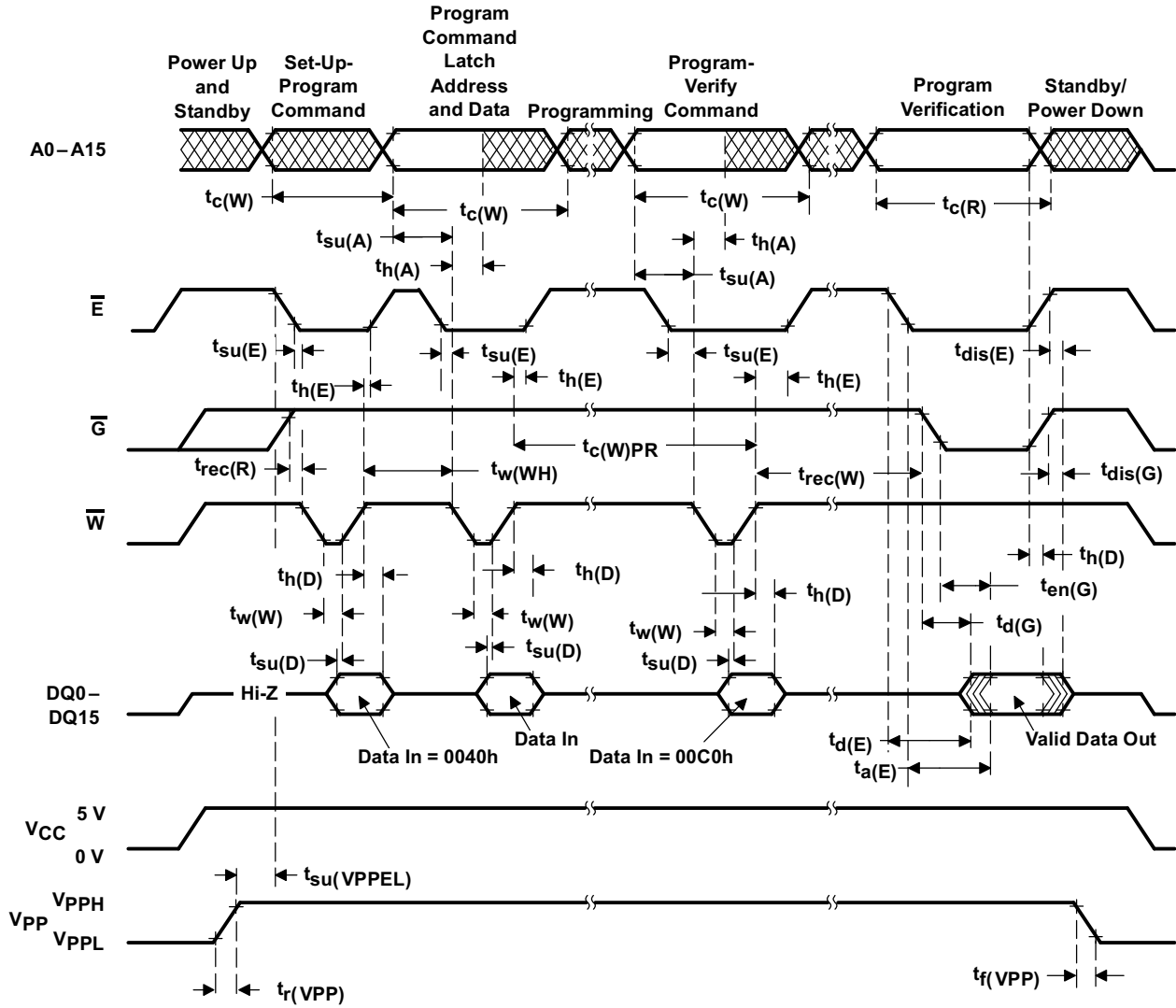

Figure 6. Write-Cycle Timing



POST OFFICE BOX 1443 • HOUSTON, TEXAS 77251-1443

PARAMETER MEASUREMENT INFORMATION

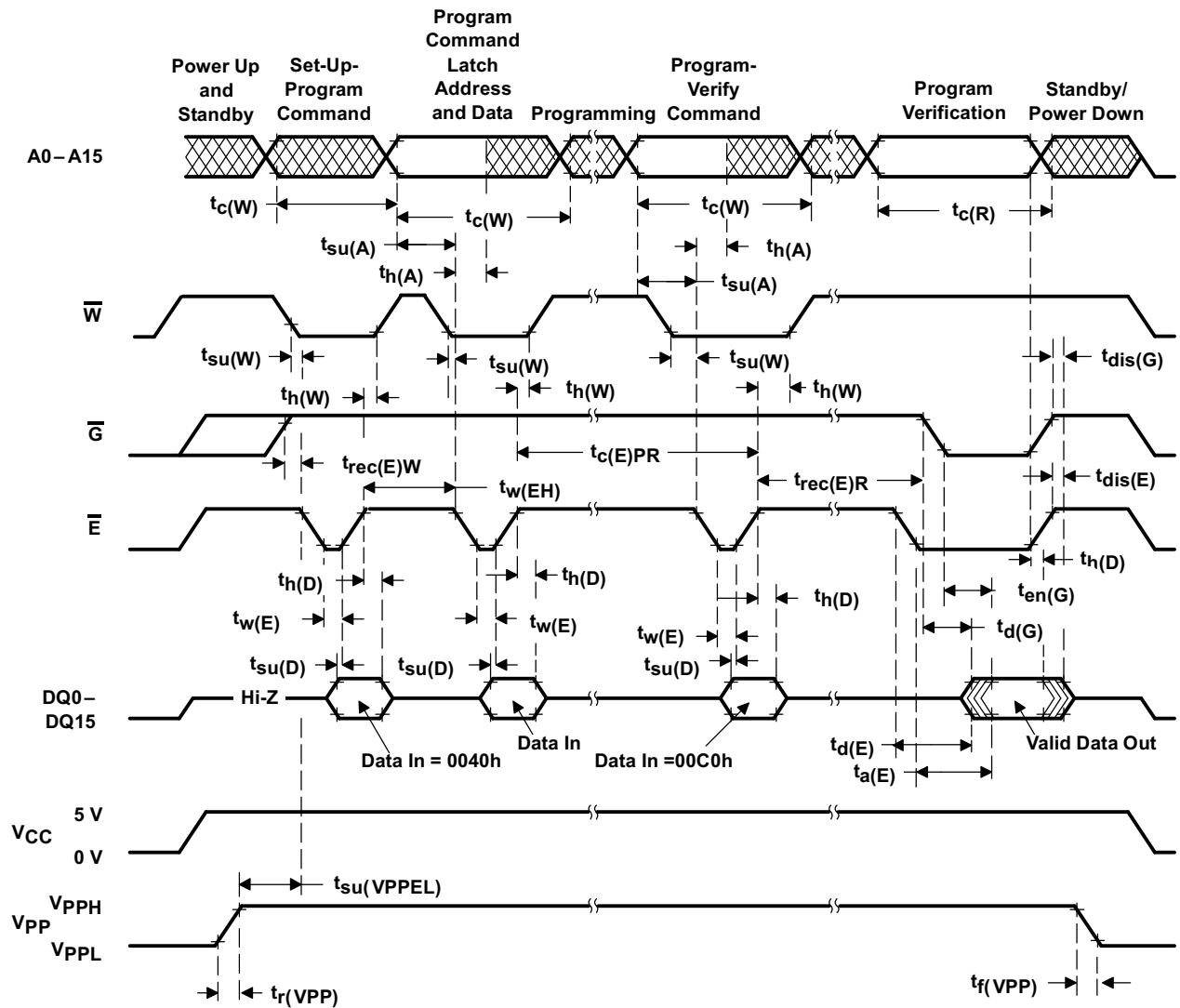

Figure 7. Write-Cycle (Alternative \bar{E} -Controlled Writes) Timing

PARAMETER MEASUREMENT INFORMATION

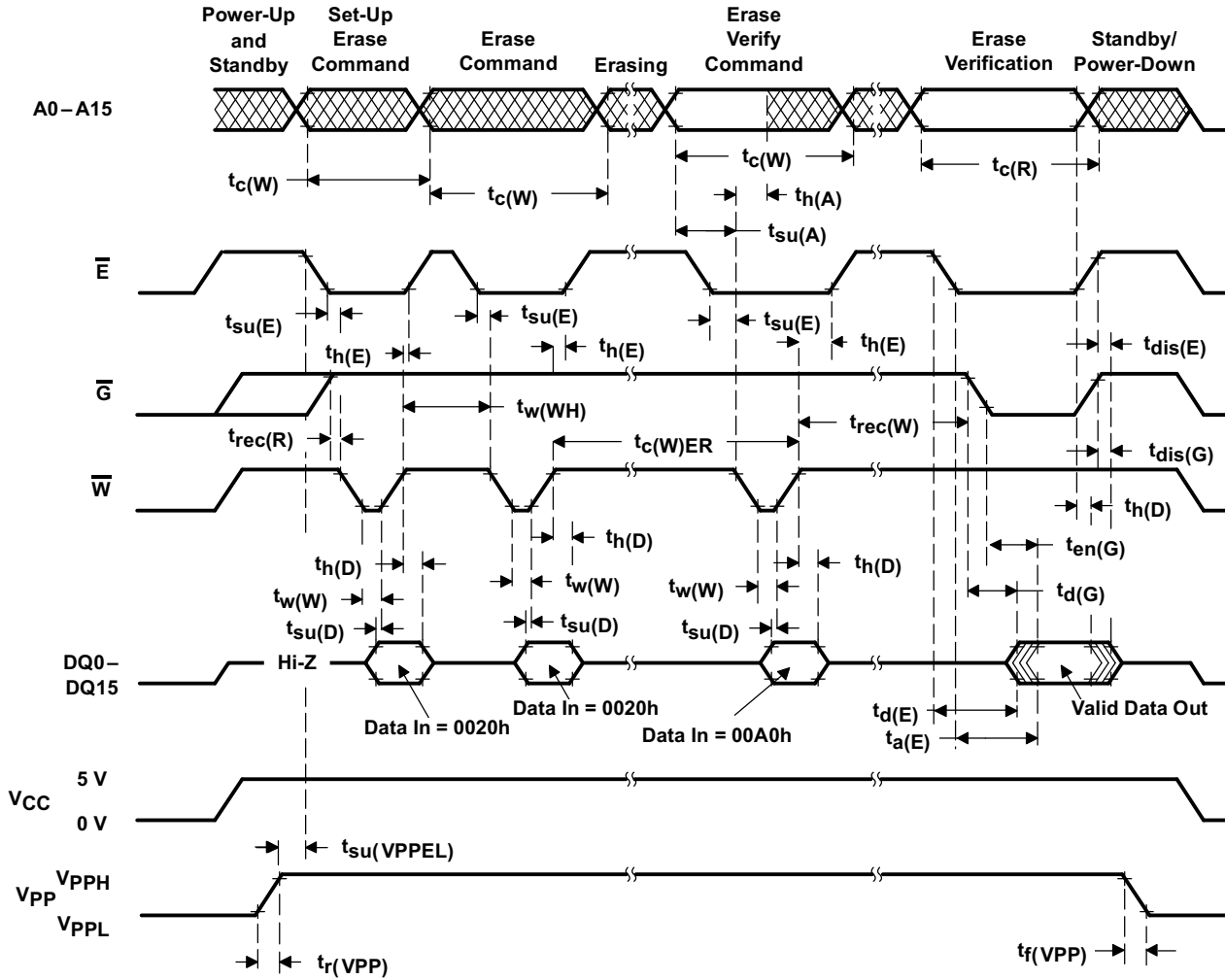

Figure 8. Flash-Erase-Cycle Timing

TMS28F210
65536 BY 16-BIT
FLASH MEMORY

SMJS210D – DECEMBER 1992 – REVISED AUGUST 1997

MECHANICAL DATA

DBW (R-PDSO-G40)

PLASTIC DUAL SMALL-OUTLINE PACKAGE

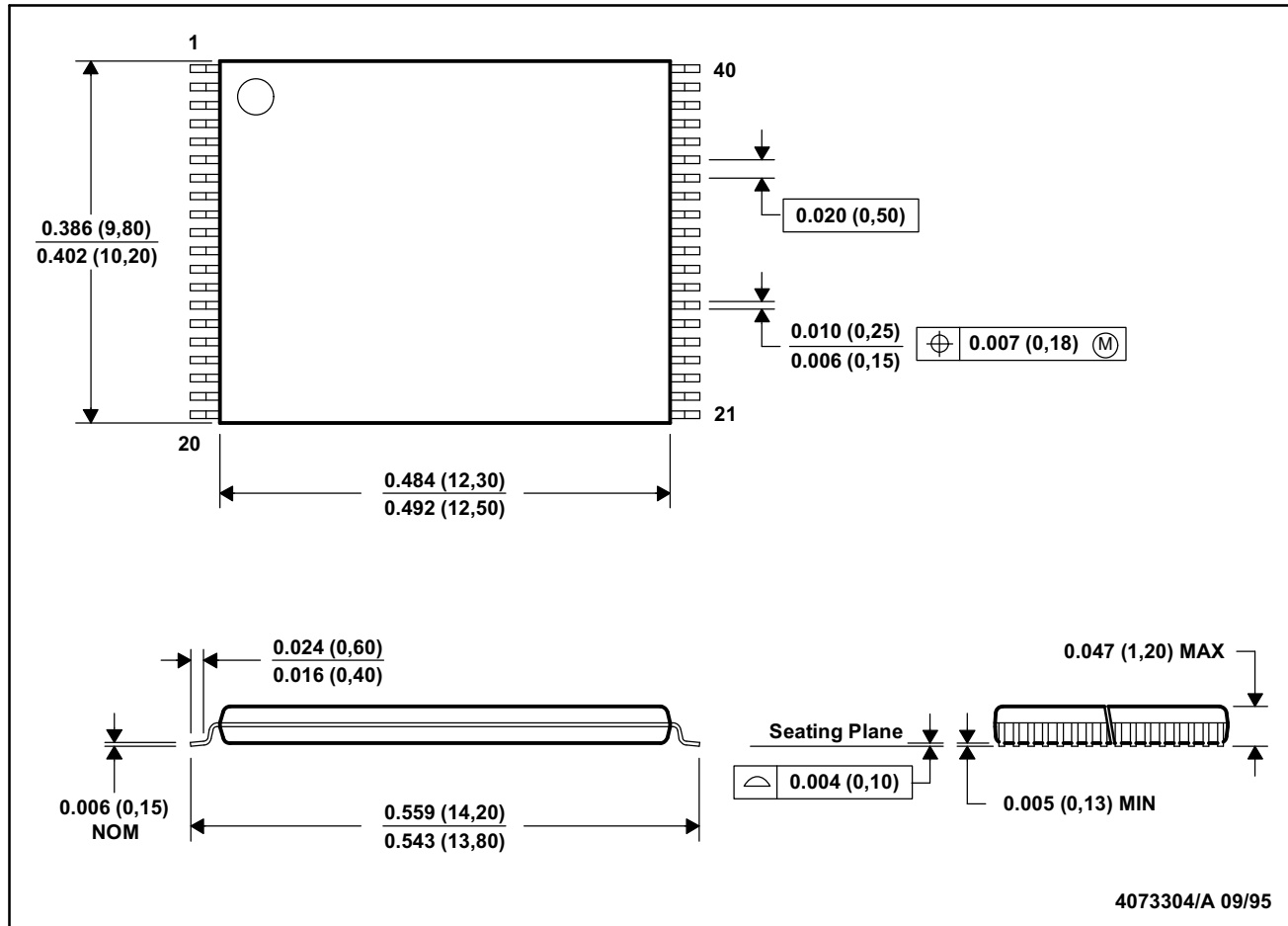

NOTES: A. All linear dimensions are in inches (millimeters).
 B. This drawing is subject to change without notice.

IMPORTANT NOTICE

Texas Instruments and its subsidiaries (TI) reserve the right to make changes to their products or to discontinue any product or service without notice, and advise customers to obtain the latest version of relevant information to verify, before placing orders, that information being relied on is current and complete. All products are sold subject to the terms and conditions of sale supplied at the time of order acknowledgement, including those pertaining to warranty, patent infringement, and limitation of liability.

TI warrants performance of its semiconductor products to the specifications applicable at the time of sale in accordance with TI's standard warranty. Testing and other quality control techniques are utilized to the extent TI deems necessary to support this warranty. Specific testing of all parameters of each device is not necessarily performed, except those mandated by government requirements.

CERTAIN APPLICATIONS USING SEMICONDUCTOR PRODUCTS MAY INVOLVE POTENTIAL RISKS OF DEATH, PERSONAL INJURY, OR SEVERE PROPERTY OR ENVIRONMENTAL DAMAGE ("CRITICAL APPLICATIONS"). TI SEMICONDUCTOR PRODUCTS ARE NOT DESIGNED, AUTHORIZED, OR WARRANTED TO BE SUITABLE FOR USE IN LIFE-SUPPORT DEVICES OR SYSTEMS OR OTHER CRITICAL APPLICATIONS. INCLUSION OF TI PRODUCTS IN SUCH APPLICATIONS IS UNDERSTOOD TO BE FULLY AT THE CUSTOMER'S RISK.

In order to minimize risks associated with the customer's applications, adequate design and operating safeguards must be provided by the customer to minimize inherent or procedural hazards.

TI assumes no liability for applications assistance or customer product design. TI does not warrant or represent that any license, either express or implied, is granted under any patent right, copyright, mask work right, or other intellectual property right of TI covering or relating to any combination, machine, or process in which such semiconductor products or services might be or are used. TI's publication of information regarding any third party's products or services does not constitute TI's approval, warranty or endorsement thereof.