

NAIS

COMPACT PC BOARD POWER RELAY

JW RELAYS

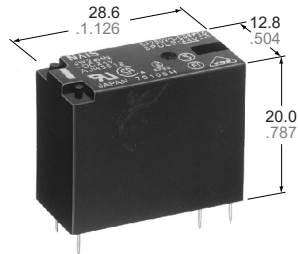

mm inch

FEATURES

- Miniature package with universal terminal footprint
- High dielectric withstanding for transient protection: 10,000 V surge in μ s between coil and contact
- Sealed construction
- Class B coil insulation types available
- TV rated (TV-5) types available (only for 1 Form A type)
- VDE, TÜV, SEMKO, SEV, FIMKO, TV-5 also approved

SPECIFICATIONS

Contact

| | | Standard type | High capacity type |
|--|---|---|--------------------------------|
| Arrangement | | 1 Form A, 1 Form C, 2 Form A, 2 Form C | 1 Form A, 1 Form C |
| Initial contact resistance, max. (By voltage drop 6 V DC 1 A) | | 100 m Ω | |
| Contact material | | Silver alloy | |
| Rating (resistive load) | Nominal switching capacity | 5 A 250 V AC, 5 A 30 V DC | 10 A 250 V AC, 10 A 30 V DC |
| | Max. switching power | 1,250 VA, 150 W | 2,500 VA, 300 W |
| | Max. switching voltage | 250 V AC, 30 V DC | |
| | Max. switching current | 5 A | 10 A |
| Expected life (min. ope.) | Mechanical (at 180 cpm) | 5 \times 10 ⁶ | |
| | Electrical (at 6 cpm) (Resistive load) | 10 ⁵ | |

Coil

| | |
|-------------------------|--------|
| Nominal operating power | 530 mW |
|-------------------------|--------|

Remarks

- * Specifications will vary with foreign standards certification ratings.
- *¹ Detection current: 10mA
- *² Wave is standard shock voltage of $\pm 1.2 \times 50\mu$ s according to JEC-212-1981
- *³ Excluding contact bounce time
- *⁴ Half-wave pulse of sine wave: 11ms; detection time: 10 μ s
- *⁵ Half-wave pulse of sine wave: 6ms
- *⁶ Detection time: 10 μ s
- *⁷ Refer to 5. Conditions for operation, transport and storage mentioned in AMBIENT ENVIRONMENT (Page 24).
- *⁸ When using relays in a high ambient temperature, consider the pick-up voltage rise due to the high temperature (a rise of approx. 0.4% V for each 1°C 33.8°F with 20°C 68°F as a reference) and use a coil impressed voltage that is within the maximum allowable voltage range.

Characteristics

| | | Standard type | High capacity type |
|---|--------------------------------|--|---|
| Max. operating speed (at rated load) | | 6 cpm | |
| Initial insulation resistance | | Min. 1,000 M Ω at 500 V DC | |
| Initial breakdown voltage* ¹ | Between open contacts | 1,000 Vrms for 1 min. | |
| | Between contacts and coil | 5,000 Vrms for 1 min. | |
| | Between contact sets | 3,000 Vrms for 1 min. (2 Form A, 2 Form C) | |
| Initial surge voltage between contacts and coil* ² | | Min. 10,000 V | |
| Operate time* ³ (at nominal voltage) | | Max. 15 ms | |
| Release time (without diode)* ³ (at nominal voltage) | | Max. 5 ms | |
| Temperature rise (at 20°C) (at nominal voltage) (with nominal coil voltage and at nominal switching capacity) | | 1a: max. 39°C 1c, 2a, 2c: max. 55°C (resistance method) | 1a: max. 45°C 1c: max. 55°C (resistance method) |
| Shock resistance | Functional* ⁴ | Min. 98 m/s ² {10 G} | |
| | Destructive* ⁵ | Min. 980 m/s ² {100 G} | |
| Vibration resistance | Functional* ⁶ | Approx. 98 m/s ² {10 G}, 10 to 55 Hz at double amplitude of 1.6 mm | |
| | Destructive | Approx. 117.6 m/s ² {12 G}, 10 to 55 Hz at double amplitude of 2.0 mm | |
| Conditions for operation, transport and storage* ⁷ (Not freezing and condens- ing at low temperature) | Ambient temp.* ⁸ | -40°C to +85°C -40°F to +185°F | |
| | Humidity | 5 to 85% R.H. | |
| Unit weight | | Approx. 13 g .46 oz | |

TYPICAL APPLICATIONS

- Home appliances
TV sets, VCR, Microwave ovens
- Office machines
Photocopiers, Vending machines
- Industrial equipment
NC machines, Robots, Temperature controllers

ORDERING INFORMATION



| Contact arrangement | Contact capacity | Protective construction | Pick-up voltage | Coil insulation class | Coil voltage |
|--|---|-------------------------|---------------------------|--|------------------------------|
| 1: 1 Form C 1a: 1 Form A 2: 2 Form C 2a: 2 Form A | Nil: Standard (5 A) F: High capacity (10 A)* | S: Sealed type | N: 70% of nominal voltage | Nil: Class E insulation B: Class B insulation | DC 5, 6, 9, 12, 18, 24, 48 V |

*Only for 1 Form A and 1 Form C type

UL/CSA, VDE, SEMKO, FIMKO, SEV approved type is standard.

Notes: 1. When ordering TV rated (TV-5) types, add suffix-TV (available only for 1 Form A type).

2. Standard packing: Carton: 100 pcs. Case: 500 pcs.

TYPES

Standard (5A) types

| Contact arrangement | Coil voltage, V DC | Part No. | Contact arrangement | Coil voltage, V DC | Part No. |
|---------------------|--------------------|--------------|---------------------|--------------------|--------------|
| 1 Form A | 5 | JW1aSN-DC5V | 2 Form A | 5 | JW2aSN-DC5V |
| | 6 | JW1aSN-DC6V | | 6 | JW2aSN-DC6V |
| | 9 | JW1aSN-DC9V | | 9 | JW2aSN-DC9V |
| | 12 | JW1aSN-DC12V | | 12 | JW2aSN-DC12V |
| | 18 | JW1aSN-DC18V | | 18 | JW2aSN-DC18V |
| | 24 | JW1aSN-DC24V | | 24 | JW2aSN-DC24V |
| | 48 | JW1aSN-DC48V | | 48 | JW2aSN-DC48V |
| 1 Form C | 5 | JW1SN-DC5V | 2 Form C | 5 | JW2SN-DC5V |
| | 6 | JW1SN-DC6V | | 6 | JW2SN-DC6V |
| | 9 | JW1SN-DC9V | | 9 | JW2SN-DC9V |
| | 12 | JW1SN-DC12V | | 12 | JW2SN-DC12V |
| | 18 | JW1SN-DC18V | | 18 | JW2SN-DC18V |
| | 24 | JW1SN-DC24V | | 24 | JW2SN-DC24V |
| | 48 | JW1SN-DC48V | | 48 | JW2SN-DC48V |

High capacity (10 A) types

| Contact arrangement | Coil voltage, V DC | Part No. | Contact arrangement | Coil voltage, V DC | Part No. |
|---------------------|--------------------|---------------|---------------------|--------------------|--------------|
| 1 Form A | 5 | JW1aFSN-DC5V | 1 Form C | 5 | JW1FSN-DC5V |
| | 6 | JW1aFSN-DC6V | | 6 | JW1FSN-DC6V |
| | 9 | JW1aFSN-DC9V | | 9 | JW1FSN-DC9V |
| | 12 | JW1aFSN-DC12V | | 12 | JW1FSN-DC12V |
| | 18 | JW1aFSN-DC18V | | 18 | JW1FSN-DC18V |
| | 24 | JW1aFSN-DC24V | | 24 | JW1FSN-DC24V |
| | 48 | JW1aFSN-DC48V | | 48 | JW1FSN-DC48V |

COIL DATA (at 20°C 68°F)

| Nominal voltage, V DC | Pick-up voltage, V DC (max.) (Initial) | Drop-out voltage, V DC (min.) (Initial) | Nominal operating current, mA (±10%) | Coil resistance, Ω (±10%) | Nominal operating power, mW | Max. allowable voltage |
|-----------------------|--|---|--------------------------------------|---------------------------|-----------------------------|--|
| 5 | 3.5 | 0.5 | 106 | 47 | 530 | 130% V of Nominal Voltage (at 60°C 140°F) 120% V of Nominal Voltage (at 85°C 185°F) |
| 6 | 4.2 | 0.6 | 88 | 68 | | |
| 9 | 6.3 | 0.9 | 58 | 155 | | |
| 12 | 8.4 | 1.2 | 44 | 270 | | |
| 18 | 12.6 | 1.8 | 29 | 611 | | |
| 24 | 16.8 | 2.4 | 22 | 1,100 | | |
| 48 | 33.6 | 4.8 | 11 | 4,400 | | |

DIMENSIONS

1 Form A

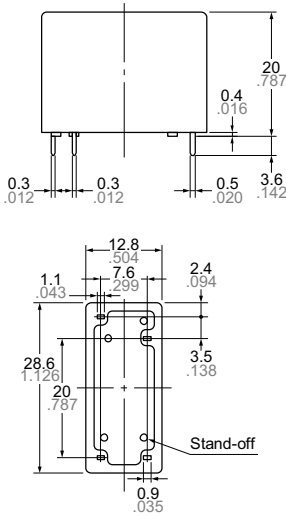

PC board pattern (Copper-side view)

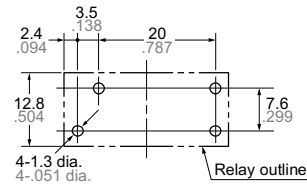

Tolerance: $\pm 0.1 \pm 0.004$

Wiring diagram (Bottom view)

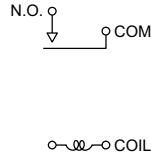

| Dimension : | General tolerance |
|----------------------------|---------------------|
| Max. 1mm .039 inch | $\pm 0.1 \pm 0.004$ |
| 1 to 3mm .039 to .118 inch | $\pm 0.2 \pm 0.008$ |
| Min. 3mm .118 inch | $\pm 0.3 \pm 0.012$ |

1 Form C

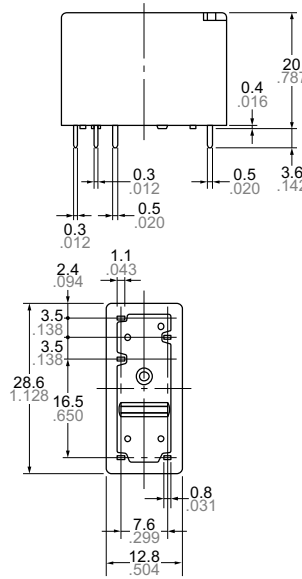

PC board pattern (Copper-side view)

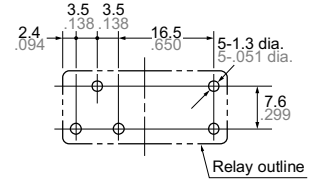

Tolerance: $\pm 0.1 \pm 0.004$

Wiring diagram (Bottom view)

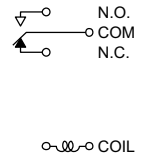

2 Form A

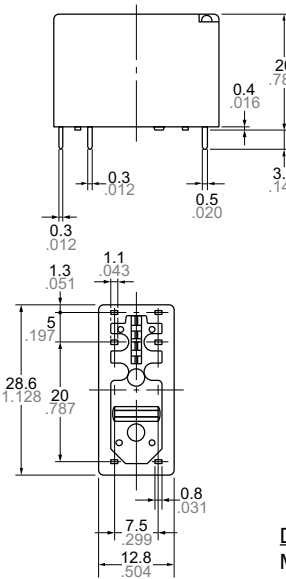

PC board pattern (Copper-side view)

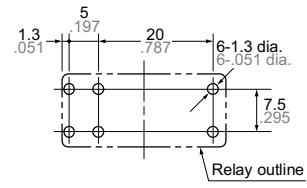

Tolerance: $\pm 0.1 \pm 0.004$

Wiring diagram (Bottom view)

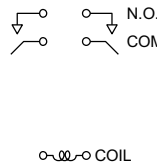

| Dimension : | General tolerance |
|----------------------------|---------------------|
| Max. 1mm .039 inch | $\pm 0.1 \pm 0.004$ |
| 1 to 3mm .039 to .118 inch | $\pm 0.2 \pm 0.008$ |
| Min. 3mm .118 inch | $\pm 0.3 \pm 0.012$ |

2 Form C

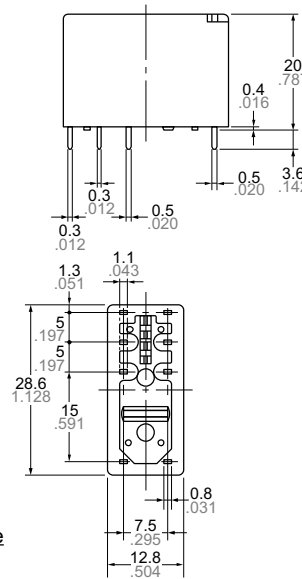

PC board pattern (Copper-side view)

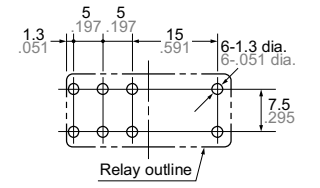

Tolerance: $\pm 0.1 \pm 0.004$

Wiring diagram (Bottom view)

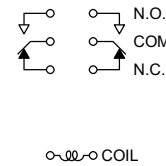

REFERENCE DATA

1-(1). Maximum operating power
1 Form A Standard (5 A) type

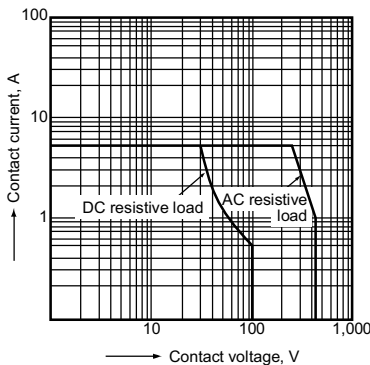

1-(2). Maximum operating power
1 Form A High Capacity (10 A) type

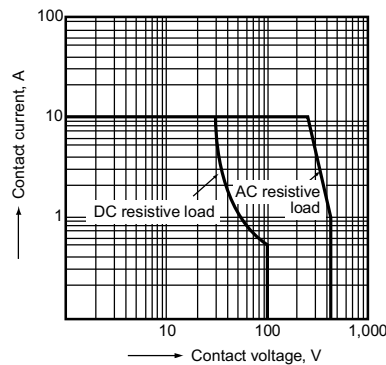

2-(1). Life curve
1 Form A Standard (5 A) type

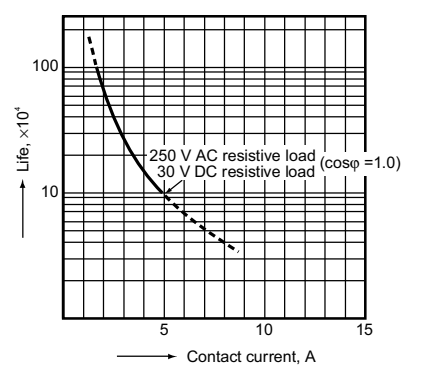

2-(2). Life curve

1 Form A High Capacity (10 A) type

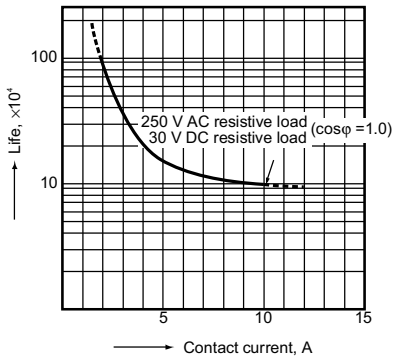

3-(1). Operate/release time

Sample: JW1aSN-DC12V, 10 pcs.
Ambient temperature: 20°C 68°F

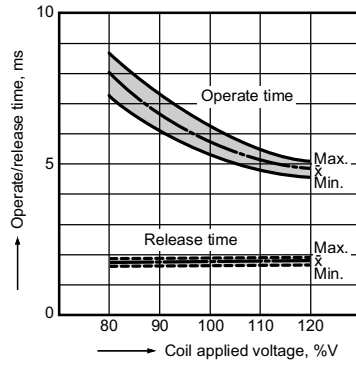

3-(2). Operate/release time

Sample: JW1aFSN-DC12V, 10 pcs.
Ambient temperature: 20°C 68°F

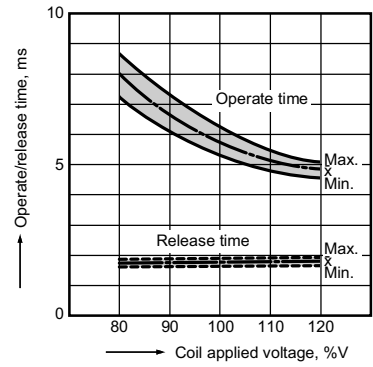

3-(3). Operate/release time

Sample: JW1SN-DC12V, 6 pcs.
Ambient temperature: 20°C 68°F

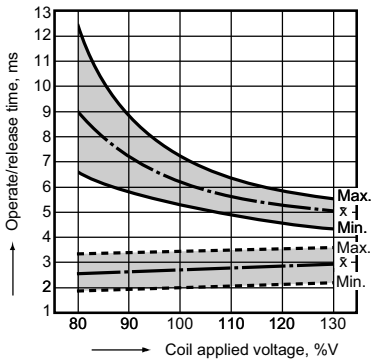

3-(4). Operate/release time

Sample: JW2aSN-DC24V, 6 pcs.
Ambient temperature: 20°C 68°F

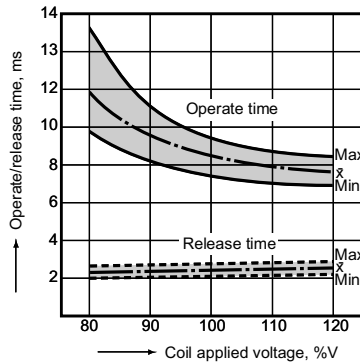

3-(5). Operate/release time

Sample: JW2SN-DC12V, 6 pcs.
Ambient temperature: 20°C 68°F

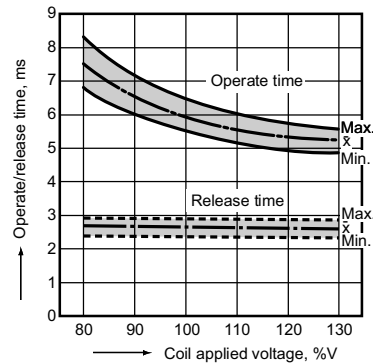

4-(1). Coil temperature rise

(Contact carrying current: 5A)

Sample: JW1aFSN-DC12V, 6 pcs.
Point measured: Inside the coil

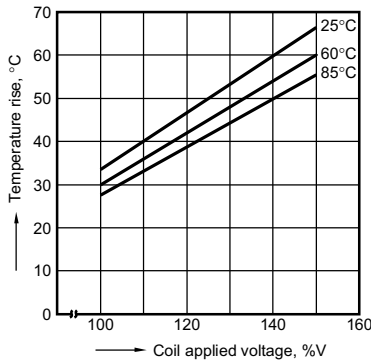

4-(2). Coil temperature rise

(Contact carrying current: 10 A)

Sample: JW1aFSN-DC12V, 6 pcs.
Point measured: Inside the coil

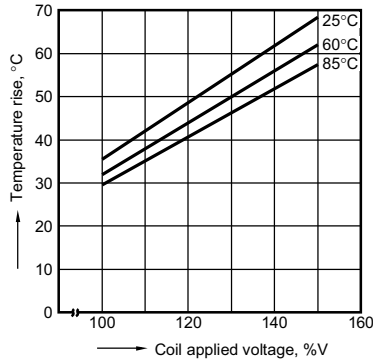

ACCESSORIES

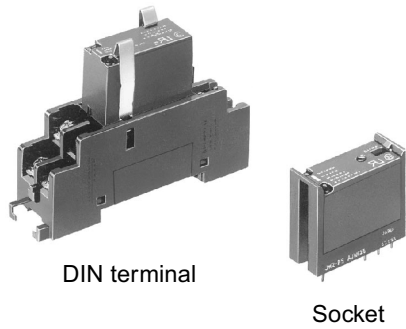

FEATURES

1. Space saving design
2. Wiring can be done with ease (DIN terminal)

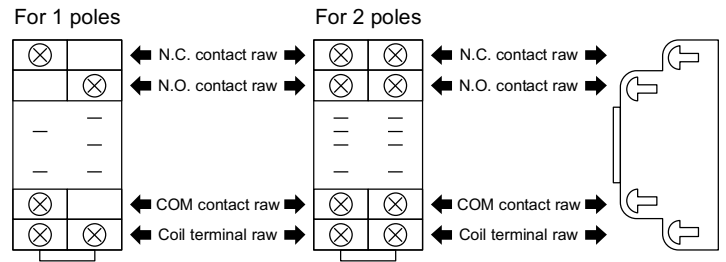

TYPES

| Product name | Number of poles | Part No. | Applicable relay type | | | | Standard packing | |
|---|-----------------|----------|-----------------------|----------|----------|----------|------------------|------------|
| | | | 1 Form A | 1 Form C | 2 Form A | 2 Form C | Inner carton | Outer case |
| JW1 DIN terminal socket (with hold-down clip) | 1 | JW1-SFD | • | • | | | 10 pcs. | 100 pcs. |
| JW2 DIN terminal socket (with hold-down clip) | 2 | JW2-SFD | | | • | • | | |
| JW1 PC board socket | 1 | JW1-PS | • | • | | | | |
| JW2 PC board socket | 2 | JW2-PS | | | • | • | | |
| JW1 Plug-in socket | 1 | JW1-SS | • | • | | | | |
| JW2 Plug-in socket | 2 | JW2-SS | | | • | • | | |

SPECIFICATIONS

| Item | Type | PC board socket/Plug-in socket | | DIN terminal socket | |
|-----------------------|------|--------------------------------|---------|-------------------------|-------------------------|
| | | 1 pole | 2 poles | 1 pole | 2 poles |
| Breakdown voltage | | 1,500 vrms for 1 minute | | 1,500 Vrms for 1 minute | 1,000 Vrms for 1 minute |
| Insulation resistance | | Min. 100 MΩ | | Min. 100 MΩ | |

DIMENSIONS

1. DIN terminal socket

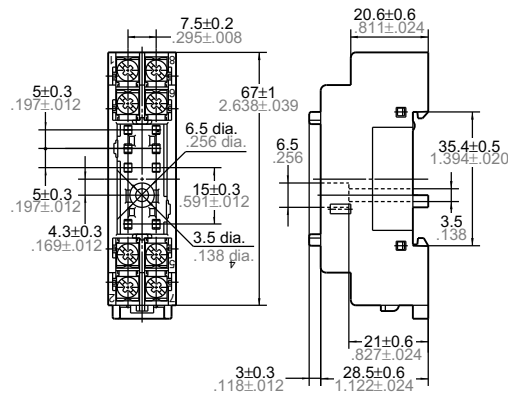

2. PC board socket

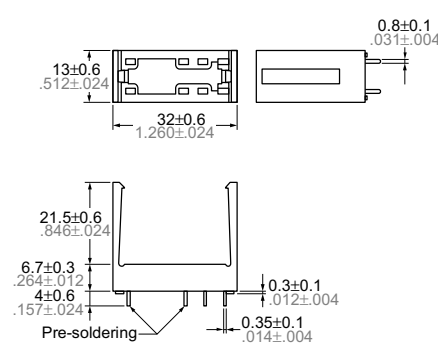

PC board pattern (Bottom view)

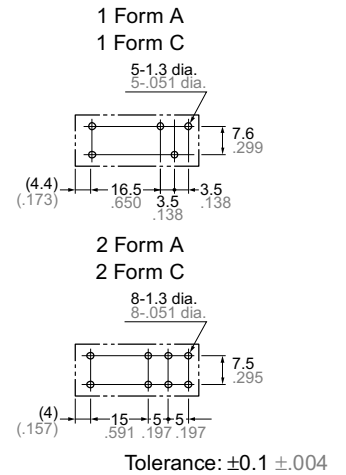

3. Plug-in socket

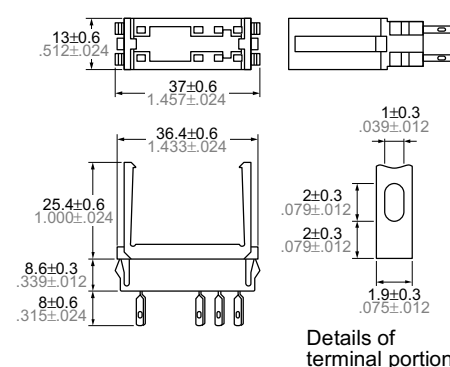

Panel cut-out
(Thickness: 1.0 to 2.0 .039 to .079)

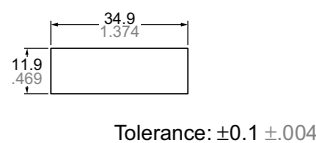

For Cautions for Use, see Relay Technical Information (Page 11 to 39).