

# Agilent HSMx-A10x-xxxxx PLCC-2 Surface Mount LED Indicator Data Sheet

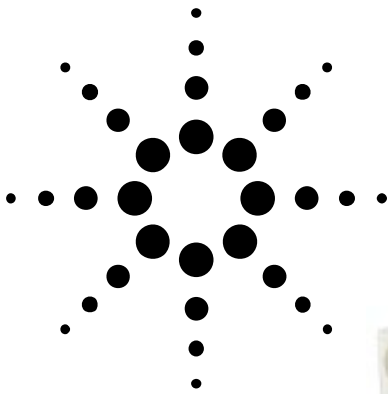

## Description

This family of SMT LEDs is packaged in the industry standard PLCC-2 package. These SMT LEDs have high reliability performance and are designed to work under a wide range of environmental conditions. This high reliability feature makes them ideally suited to be used under harsh interior automotive as well as interior signs application conditions.

To facilitate easy pick & place assembly, the LEDs are packed in EIA-compliant tape and reel. Every reel will be shipped in single intensity and color bin, except red color, to provide close uniformity.

These LEDs are compatible with IR solder reflow process. Due to the high reliability feature of these products, they can also be mounted using through-the-wave soldering process.

The super wide viewing angle at 120° makes these LEDs ideally suited for panel, push button, or general backlighting in automotive interior, office equipment, industrial equipment, and home appliances. The flat top emitting surface makes it easy for these LEDs to mate with light pipes. With the built-in reflector pushing up the intensity of the light output, these LEDs are also suitable to be used as LED pixels in interior electronic signs.

## Features

- Industry standard PLCC-2 package
- High reliability LED package
- High brightness using AlInGaP and InGaN dice technologies
- Available in full selection of colors
- Super wide viewing angle at 120°
- Available in 8 mm carrier tape on 7 inch reel
- Compatible with both IR and TTW soldering process

## Applications

- Interior automotive
  - Instrument panel backlighting
  - Central console backlighting
  - Cabin backlighting
- Electronic signs and signals
  - Interior full color sign
  - Variable message sign
- Office automation, home appliances, industrial equipment
  - Front panel backlighting
  - Push button backlighting
  - Display backlighting

*CAUTION: HSMN-, HSMM-, and HSMK-A10x-xxxxx LEDs are Class 2 ESD sensitive. Please observe appropriate precautions during handling and processing. Refer to Agilent Application Note AN-1142 for additional details.*

## Package Dimensions

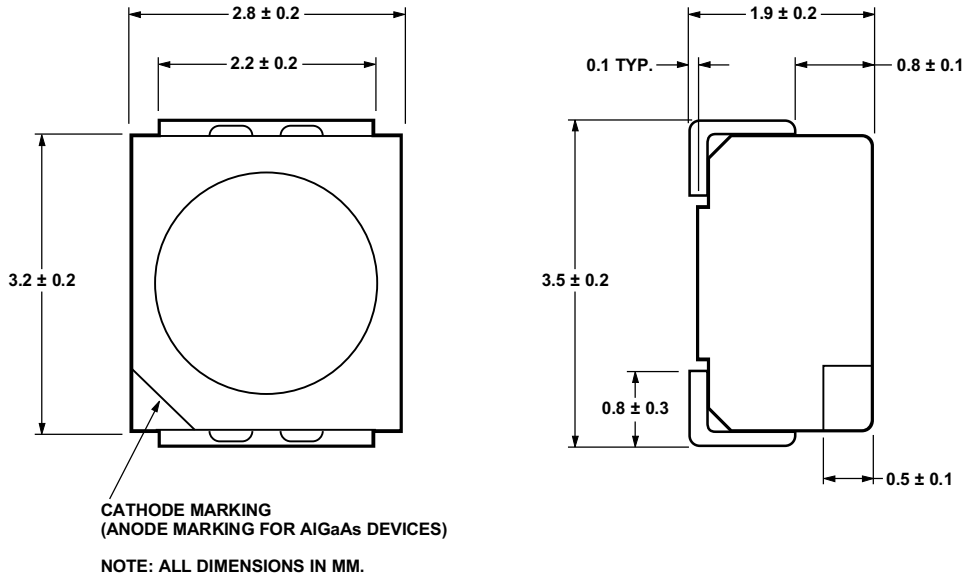

## Device Selection Guide

Color	Part Number	Min. $I_v$ @ 20 mA	Typical $I_v$ @ 20 mA	Dice Technology
Red	HSMS-A100-J00J1	4	15	GaP
	HSMH-A100-L00J1	10	50	AS AlGaAs
	HSMC-A100-Q00J1	63	100	AS AlInGaP
	HSMC-A101-S00J1	160	240	AS AlInGaP
	HSMZ-A100-R00J1	100	400	TS AlInGaP
Red Orange	HSMJ-A100-Q00J1	63	200	AS AlInGaP
	HSMJ-A101-S00J1	160	240	AS AlInGaP
	HSMV-A100-R00J1	100	350	TS AlInGaP
Orange	HSMD-A100-J00J1	4	15	GaP
	HSML-A100-Q00J1	63	160	AS AlInGaP
	HSML-A101-T00J1	250	330	AS AlInGaP
Amber	HSMY-A100-J00J1	4	12	GaP
	HSMA-A100-Q00J1	63	100	AS AlInGaP
	HSMA-A101-T00J1	250	330	AS AlInGaP
	HSMU-A100-R00J1	100	270	TS AlInGaP
Yellow Green	HSMG-A100-J02J1	4	18	GaP
Emerald Green	HSMG-A100-H01J1	2.5	8	GaP
Green	HSMM-A100-S00J1	160	280	InGaN
	HSMM-A101-R00J1	100	200	InGaN
Cyan	HSMK-A100-S00J1	160	280	InGaN
	HSMK-A101-R00J1	100	170	InGaN
Blue	HSMB-A100-J00J1	4	15	GaN
	HSMN-A101-N00J1	25	50	InGaN
	HSMN-A100-P00J1	40	70	InGaN

### Note:

- The luminous intensity,  $I_v$ , is measured at the mechanical axis of the lamp package. The actual peak of the spatial radiation pattern may not be aligned with this axis.

## Part Numbering System

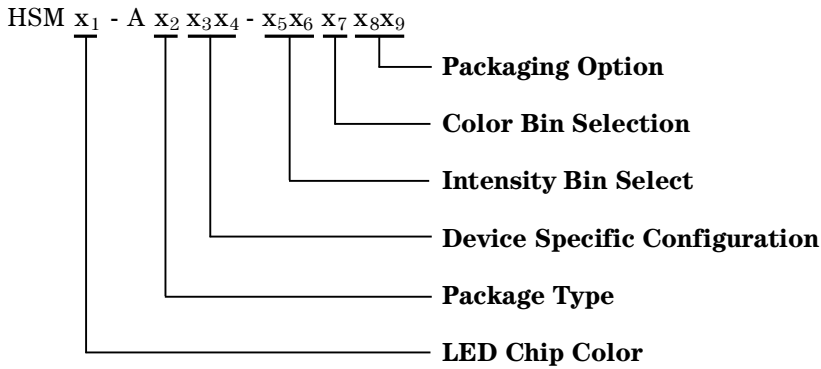

## Absolute Maximum Ratings at T<sub>A</sub> = 25°C

Parameters	GaP	AlGaAs	AS AlInGaP	TS AlInGaP	GaN/InGaN
DC Forward Current <sup>[1]</sup>	30 mA	30 mA	30 mA <sup>[3,4]</sup>	30 mA <sup>[3,4]</sup>	30 mA
Peak Forward Current <sup>[2]</sup>	100 mA	100 mA	100 mA	100 mA	100 mA
Power Dissipation	63 mW	60 mW	63 mW	72 mW	114 mW
Reverse Voltage	5 V	5 V	5 V	5 V	5 V
Junction Temperature	110°C	110°C	110°C	110°C	110°C
Operating Temperature	-55°C to +100°C	-55°C to +100°C	-55°C to +100°C	-55°C to +100°C	-55°C to +100°C
Storage Temperature	-55°C to +100°C	-55°C to +100°C	-55°C to +100°C	-55°C to +100°C	-55°C to +100°C

### Notes:

1. Derate linearly as shown in Figure 4.
2. Duty factor = 10%, Frequency = 1 kHz.
3. Drive current between 10 mA and 30 mA is recommended for best long term performance.
4. Operation at current below 5 mA is not recommended.

### Optical Characteristics at T<sub>A</sub> = 25°C

Color	Part Number	Dice Technology	Peak Wavelength $\lambda_{\text{peak}}$ (nm) Typ.	Dominant Wavelength $\lambda_{\text{D}}$ (nm) Typ.	Viewing Angle $2 \theta_{1/2}$ (Degrees) Typ.	Luminous Efficacy $\eta_v$ <sup>[5]</sup> (lm/w) Typ.	Luminous Intensity/ Total Flux $I_v(\text{mcd})/\phi_v(\text{lm})$ Typ.
Red	HSMS-A100	GaP	635	626	120	120	0.45
	HSMH-A100	AS AlGaAs	645	637	120	63	0.45
	HSMC-A10x	AS AlInGaP	635	626	120	150	0.45
	HSMZ-A100	TS AlInGaP	639	630	120	155	0.45
Red Orange	HSMJ-A10x	AS AlInGaP	621	615	120	240	0.45
	HSMV-A100	TS AlInGaP	623	617	120	263	0.45
Orange	HSM D-A100	GaP	600	602	120	380	0.45
	HSM L-A10x	AS AlInGaP	609	605	120	320	0.45
Amber	HSM Y-A100	GaP	583	585	120	520	0.45
	HSM A-A10x	AS AlInGaP	592	590	120	480	0.45
	HSM U-A100	TS AlInGaP	594	592	120	500	0.45
Yellow Green	HSM G-A100	GaP	565	569	120	590	0.45
Emerald Green	HSM G-A100	GaP	558	560	120	650	0.45
Green	HSM M-A10x	InGaN	523	525	120	500	0.45
Cyan	HSM K-A10x	InGaN	502	505	120	300	0.45
Blue	HSM B-A100	GaN	428	462	120	65	0.45
	HSM N-A10x	InGaN	468	470	120	75	0.45

#### Notes:

1. The dominant wavelength,  $\lambda_{\text{D}}$ , is derived from the CIE Chromaticity Diagram and represents the color of the device.
2.  $\theta_{1/2}$  is the off-axis angle where the luminous intensity is 1/2 the peak intensity.
3. Radiant intensity,  $I_e$  in watts/steradian, may be calculated from the equation  $I_e = I_v/\eta_v$ , where  $I_v$  is the luminous intensity in candelas and  $\eta_v$  is the luminous efficacy in lumens/watt.

### Electrical Characteristics at T<sub>A</sub> = 25°C

Dice Technology	Forward Voltage $V_F$ (Volts) @ $I_F = 20 \text{ mA}$		Reverse Voltage $V_R$ @ $100 \mu\text{A}$	Reverse Voltage $V_R$ @ $10 \mu\text{A}$
	Typ.	Max.	Min.	Min.
GaP	2.2	2.6	5	—
AS AlGaAs	1.9	2.6	5	—
AS AlInGaP	1.9	2.4	5	—
TS AlInGaP	2.2	2.6	5	—
GaN	3.9	4.3	—	5
InGaN Cyan	3.5	4.3	—	5
InGaN Green	3.7	4.3	—	5
InGaN Blue	3.9	4.3	—	5

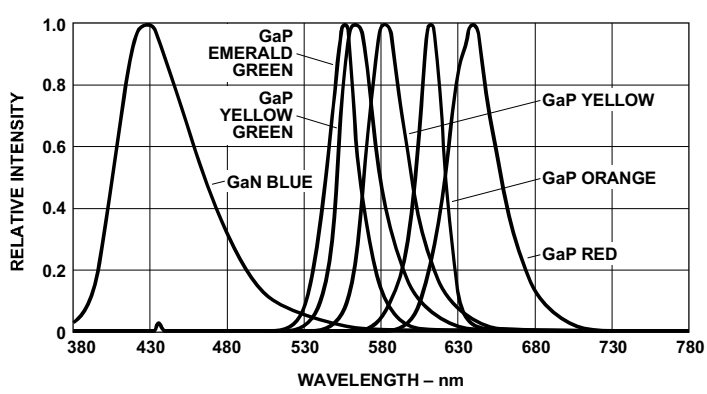
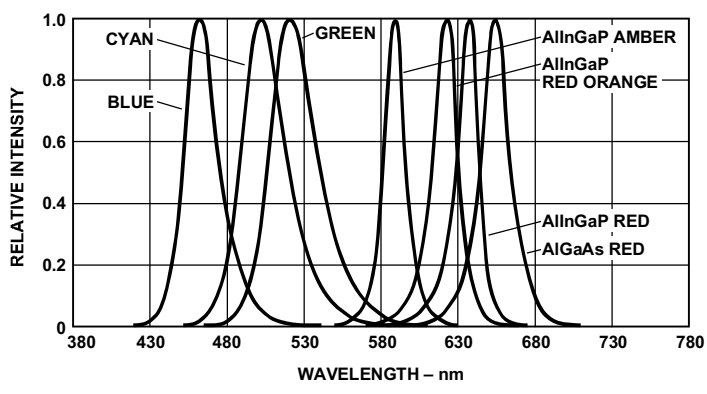

Figure 1. Relative intensity vs. wavelength.

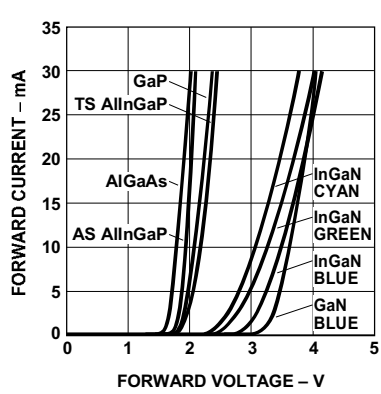

Figure 2. Forward current vs. forward voltage.

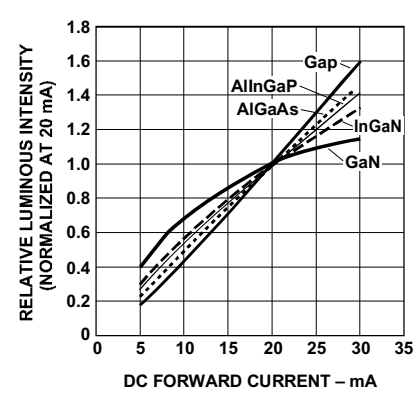

Figure 3. Relative intensity vs. forward current.

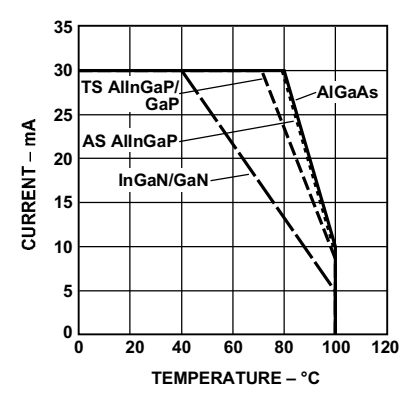

Figure 4. Maximum forward current vs. ambient temperature. Derated based on  $T_{JMAX} = 110^{\circ}C$ ,  $R_{\theta JA} = 500^{\circ}C/W$ .

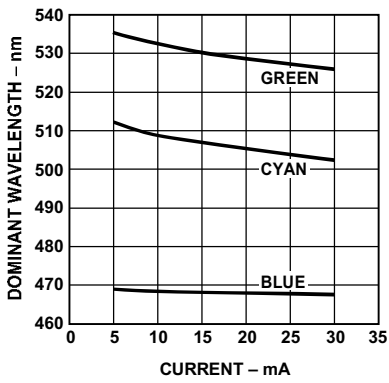

Figure 5. Dominant wavelength vs. forward current – InGaN devices.

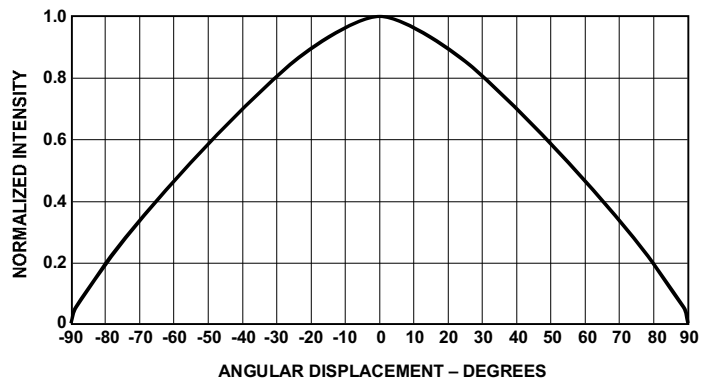

Figure 6. Radiation Pattern.

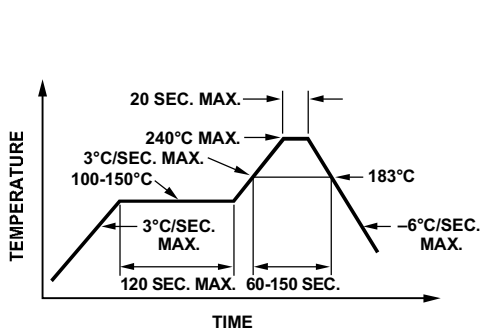

Figure 7. Recommended reflow soldering profile.

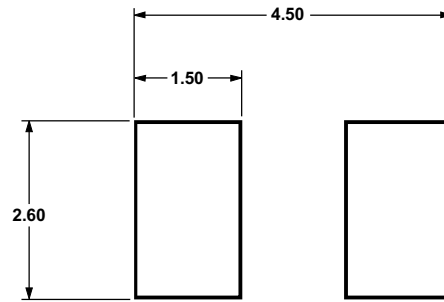

Figure 8. Recommended soldering pad pattern.

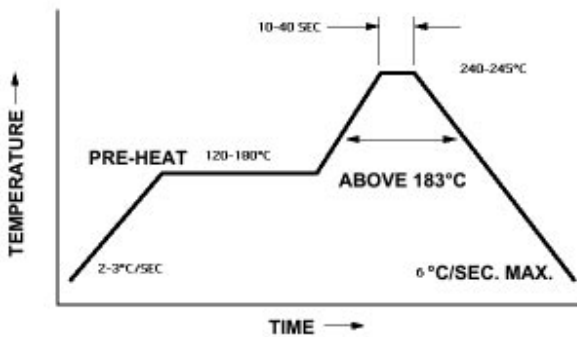
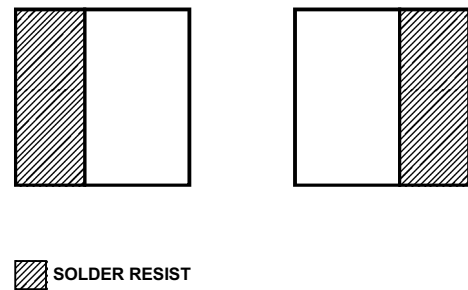

Figure 7a. Recommended wave soldering profile.



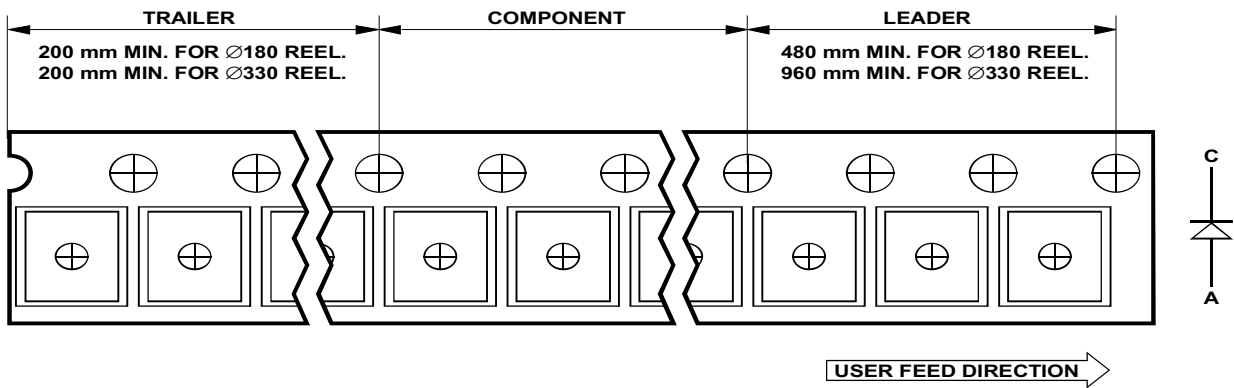

Figure 9. Tape leader and trailer dimension.

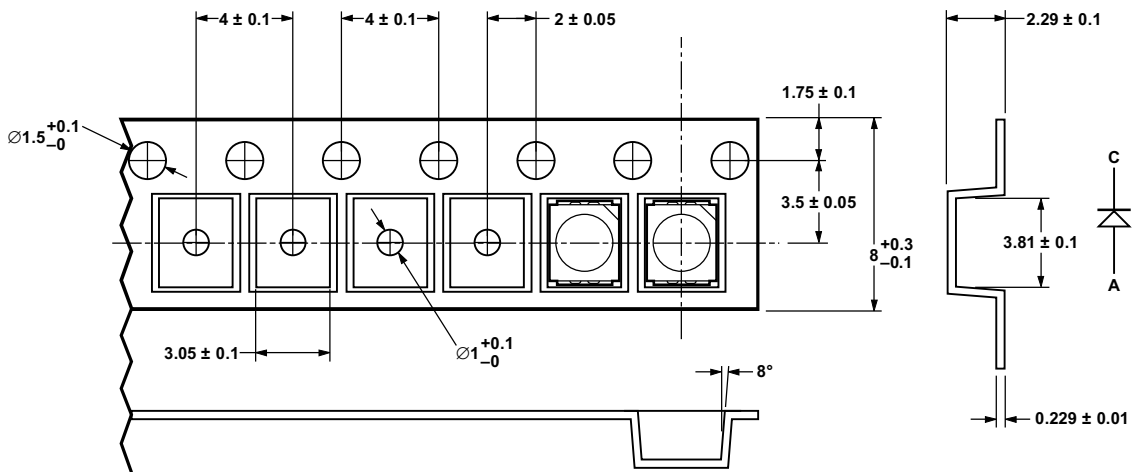

Figure 10. Tape dimension.

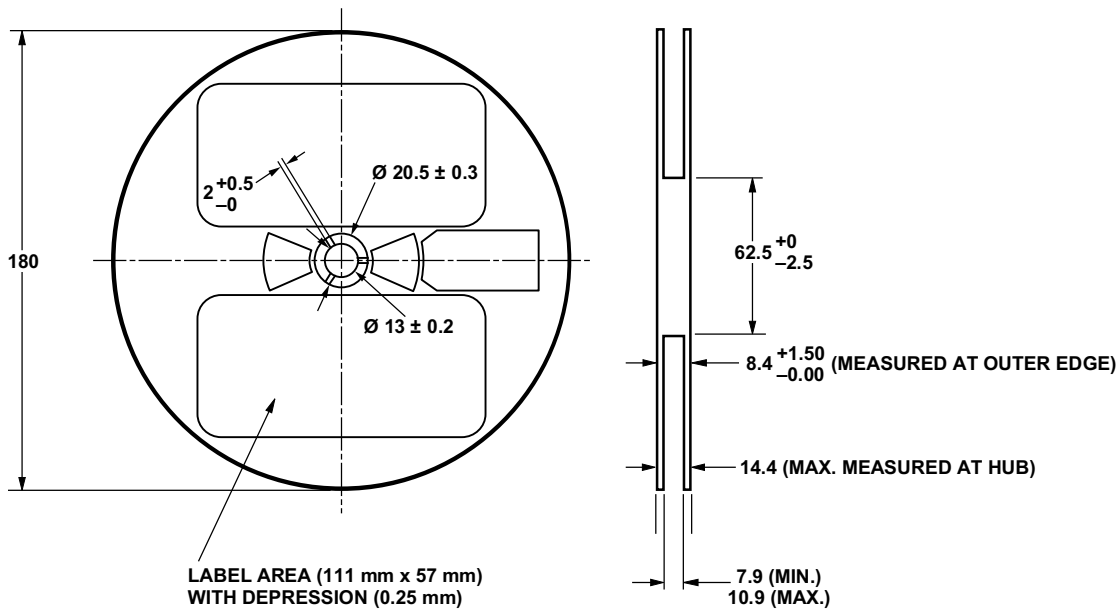

Figure 11. Reel dimension.

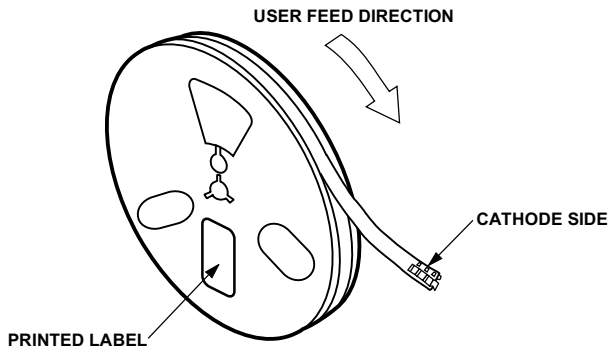

Figure 12. Reeling orientation.

Baking is required under the following conditions:

- a) the humidity indicator turns pink
- b) the pack has been opened for more than four weeks.

Baking recommended condition:  $60 \pm 5^\circ\text{C}$  for 20 hours.

This product is qualified as Moisture Sensitive JEDEC Level 2A.



**Intensity Bin Select (X<sub>5</sub>X<sub>6</sub>)**

Individual reel will contain parts from one half bin only.

X <sub>5</sub>	Min I <sub>v</sub> Bin
<b>X<sub>6</sub></b>	
0	Full Distribution
3	3 half bins starting from X <sub>5</sub> 1
4	4 half bins starting from X <sub>5</sub> 1
5	5 half bins starting from X <sub>5</sub> 1
7	3 half bins starting from X <sub>5</sub> 2
8	4 half bins starting from X <sub>5</sub> 2
9	5 half bins starting from X <sub>5</sub> 2

**Intensity Bin Limits**

Bin ID	Min. (mcd)	Max. (mcd)
G1	1.80	2.24
G2	2.24	2.80
H1	2.80	3.55
H2	3.55	4.50
J1	4.50	5.60
J2	5.60	7.20
K1	7.20	9.00
K2	9.00	11.20
L1	11.20	14.00
L2	14.00	18.00
M1	18.00	22.40
M2	22.40	28.50
N1	28.50	35.50
N2	35.50	45.00
P1	45.00	56.00
P2	56.00	71.50
Q1	71.50	90.00
Q2	90.00	112.50
R1	112.50	140.00
R2	140.00	180.00
S1	180.00	224.00
S2	224.00	285.00
T1	285.00	355.00
T2	355.00	450.00
U1	450.00	560.00
U2	560.00	715.00
V1	715.00	900.00
V2	900.00	1125.00

Tolerance of each bin limit = ± 12%.

**Color Bin Select (X<sub>7</sub>)**

Individual reel will contain parts from one full bin only.

X <sub>7</sub>	
0	Full Distribution
Z	A and B only
Y	B and C only
W	C and D only
V	D and E only
U	E and F only
T	F and G only
S	G and H only
Q	A, B, and C only
P	B, C, and D only
N	C, D, and E only
M	D, E, and F only
L	E, F, and G only
K	F, G, and H only
1	A, B, C, and D only
2	E, F, G, and H only

**Color Bin Limits**

Blue	Min. (nm)	Max. (nm)
A	460.0	465.0
B	465.0	470.0
C	470.0	475.0
D	475.0	480.0
<b>Green</b>		
Green	Min. (nm)	Max. (nm)
A	515.0	520.0
B	520.0	525.0
C	525.0	530.0
D	530.0	535.0
<b>Cyan</b>		
Cyan	Min. (nm)	Max. (nm)
A	490.0	495.0
B	495.0	500.0
C	500.0	505.0
D	505.0	510.0

**Color Bin Limits**

<b>Emerald</b>		
Green	Min. (nm)	Max. (nm)
A	552.5	555.5
B	555.5	558.5
C	558.5	561.5
D	561.5	564.5

<b>Yellow</b>		
Green	Min. (nm)	Max. (nm)
E	564.5	567.5
F	567.5	570.5
G	570.5	573.5
H	573.5	576.5

<b>Amber</b>		
Min. (nm)	Max. (nm)	
A	582.0	584.5
B	584.5	587.0
C	587.0	589.5
D	589.5	592.0
E	592.0	594.5
F	594.5	597.0

<b>Orange</b>		
Min. (nm)	Max. (nm)	
A	597.0	600.0
B	600.0	603.0
C	603.0	606.0
D	606.0	609.0
E	609.0	612.0

<b>Red Orange</b>		
Min. (nm)	Max. (nm)	
A	611.0	616.0
B	616.0	620.0

<b>Red</b>		
Min. (nm)	Max. (nm)	
Full Distribution		
Tolerance of each bin limit = ± 1 nm.		

<b>X<sub>8</sub>X<sub>9</sub></b>	
J1	20 mA test current, Top Mount, 7 inch Reel
J2	10 mA test current, Top Mount, 7 inch Reel

**[www.agilent.com/semiconductors](http://www.agilent.com/semiconductors)**

For product information and a complete list of distributors, please go to our web site.

For technical assistance call:

Americas/Canada: +1 (800) 235-0312 or  
(408) 654-8675

Europe: +49 (0) 6441 92460

China: 10800 650 0017

Hong Kong: (+65) 6271 2451

India, Australia, New Zealand: (+65) 6271 2394

Japan: (+81 3) 3335-8152(Domestic/International), or 0120-61-1280(Domestic Only)

Korea: (+65) 6271 2194

Malaysia, Singapore: (+65) 6271 2054

Taiwan: (+65) 6271 2654

Data subject to change.

Copyright © 2002 Agilent Technologies, Inc.

Obsoletes 5988-5762EN

April 6, 2002

5988-6183EN



**Agilent Technologies**