



Low Power/Voltage CMOS SRAM 512K X 8 bit

BS62LV4001

FEATURES

- Wide Vcc operation voltage : 2.4V ~ 5.5V
- Low power consumption
 - Vcc = 3.0V C-grade: 20mA (Max.) operating current
I-grade: 25mA (Max.) operating current
0.25uA (Typ.) CMOS standby current
 - Vcc = 5.0V C-grade: 45mA (Max.) operation current
I-grade: 50mA (Max.) operating current
1.5uA (Typ.) CMOS standby current
- High speed access time :
 - 70 70ns (Max.) at Vcc = 3.0V
 - 10 100ns (Max.) at Vcc = 3.0V
- Automatic power down when chip is deselected
- Three state outputs and TTL compatible
- Fully static operation
- Data retention supply voltage as low as 1.5V
- Easy expansion with CE and OE options

GENERAL DESCRIPTION

The BS62LV4001 is a high performance, low power CMOS Static Random Access Memory organized as 524,288 words by 8 bits and operates from a wide range of 2.4V to 5.5V supply voltage. Advanced CMOS technology and circuit techniques provide both high speed and low power features with maximum access time of 70/ 100ns in 3.0V operation. Easy memory expansion is provided by an active LOW chip enable (CE), and active LOW output enable (OE) and three-state output drivers. The BS62LV4001 has an automatic power down feature, reducing the power consumption significantly when chip is deselected. The BS62LV4001 is available in DICE form, JEDEC standard 32 pin SOP, 32 pin TSOPII, 32 pin TSOP and 32 pin Small SOP.

PRODUCT FAMILY

PRODUCT FAMILY	OPERATING TEMPERATURE	Vcc RANGE	SPEED (ns)	POWER DISSIPATION				PKG TYPE
				STANDBY (ICCSB1, Max)		Operating (ICC, Max)		
				Vcc=3.0V	Vcc=5.0V	Vcc=3.0V	Vcc=5.0V	
BS62LV4001SC	+0°C to +70°C	2.4V ~ 5.5V	70 / 100	1.5uA	15uA	20mA	45mA	SOP-32
BS62LV4001EC								TSOP2-32
BS62LV4001TC								TSOP-32
BS62LV4001STC								STSOP-32
BS62LV4001PC								PDIP-32
BS62LV4001DC								DICE
BS62LV4001SI	-40°C to +85°C	2.4V ~ 5.5V	70 / 100	3uA	50uA	25mA	50mA	SOP-32
BS62LV4001EI								TSOP2-32
BS62LV4001TI								TSOP-32
BS62LV4001STI								STSOP-32
BS62LV4001PI								PDIP-32
BS62LV4001DI								DICE

PIN CONFIGURATIONS

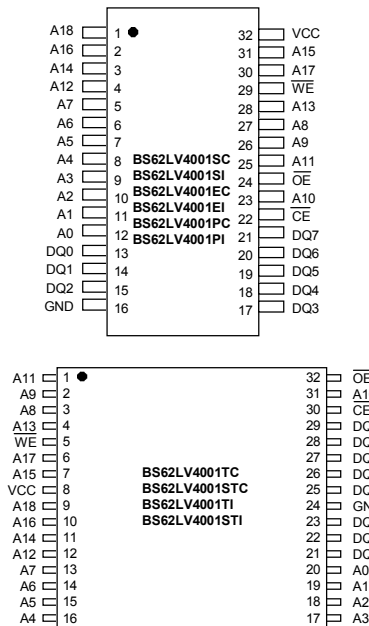

FUNCTIONAL BLOCK DIAGRAM

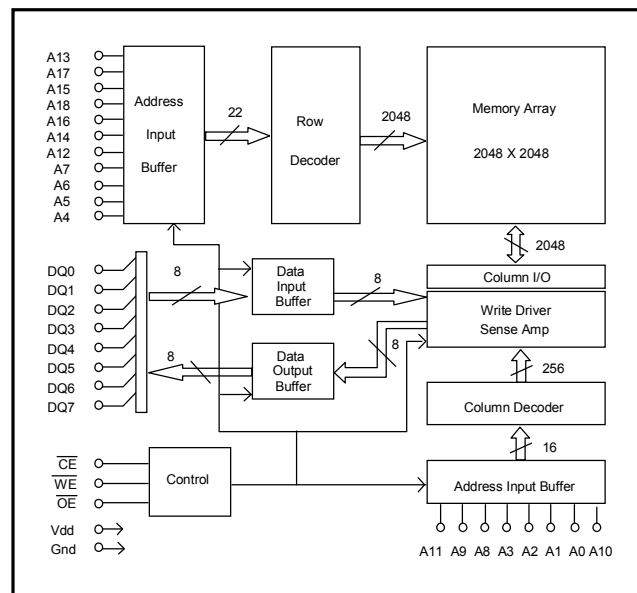

Brilliance Semiconductor Inc. reserves the right to modify document contents without notice.

■ PIN DESCRIPTIONS

Name	Function
A0-A18 Address Input	These 19 address inputs select one of the 524,288 x 8-bit words in the RAM
\overline{CE} Chip Enable Input	\overline{CE} is active LOW. Chip enable must be active when data read from or write to the device. if chip enable is not active, the device is deselected and is in a standby power mode. The DQ pins will be in the high impedance state when the device is deselected.
\overline{WE} Write Enable Input	The write enable input is active LOW and controls read and write operations. With the chip selected, when \overline{WE} is HIGH and \overline{OE} is LOW, output data will be present on the DQ pins; when \overline{WE} is LOW, the data present on the DQ pins will be written into the selected memory location.
\overline{OE} Output Enable Input	The output enable input is active LOW. If the output enable is active while the chip is selected and the write enable is inactive, data will be present on the DQ pins and they will be enabled. The DQ pins will be in the high impedance state when \overline{OE} is inactive.
DQ0-DQ7 Data Input/Output Ports	These 8 bi-directional ports are used to read data from or write data into the RAM.
Vcc	Power Supply
Gnd	Ground

■ TRUTH TABLE

MODE	\overline{WE}	\overline{CE}	\overline{OE}	I/O OPERATION	Vcc CURRENT
Not selected	X	H	X	High Z	I_{CCSB}, I_{CCSB1}
Output Disabled	H	L	H	High Z	I_{CC}
Read	H	L	L	DOUT	I_{CC}
Write	L	L	X	DIN	I_{CC}

■ ABSOLUTE MAXIMUM RATINGS⁽¹⁾

SYMBOL	PARAMETER	RATING	UNITS
VTERM	Terminal Voltage with Respect to GND	-0.5 to Vcc+0.5	V
TBIAS	Temperature Under Bias	-40 to +125	°C
TSTG	Storage Temperature	-60 to +150	°C
PT	Power Dissipation	1.0	W
IOUT	DC Output Current	20	mA

1. Stresses greater than those listed under ABSOLUTE MAXIMUM RATINGS may cause permanent damage to the device. This is a stress rating only and functional operation of the device at these or any other conditions above those indicated in the operational sections of this specification is not implied. Exposure to absolute maximum rating conditions for extended periods may affect reliability.

■ OPERATING RANGE

RANGE	AMBIENT TEMPERATURE	Vcc
Commercial	0 °C to +70 °C	2.4~5.5V
Industrial	-40 °C to +85 °C	2.4~5.5V

■ CAPACITANCE ⁽¹⁾ (TA = 25°C, f = 1.0 MHz)

SYMBOL	PARAMETER	CONDITIONS	MAX.	UNIT
CIN	Input Capacitance	VIN=0V	6	pF
CDQ	Input/Output Capacitance	V I/O=0V	8	pF

1. This parameter is guaranteed and not tested.

DC ELECTRICAL CHARACTERISTICS (TA = 0 to + 70°C)

PARAMETER NAME	PARAMETER	TEST CONDITIONS	MIN.	TYP. ⁽¹⁾	MAX.	UNITS	
V _{IL}	Guaranteed Input Low Voltage ⁽²⁾		-0.5	--	0.8	V	
V _{IH}	Guaranteed Input High Voltage ⁽²⁾	V _{CC} =3.0V	2.0	--	V _{CC} +0.2	V	
		V _{CC} =5.0V	2.2				
I _{IL}	Input Leakage Current	V _{CC} = Max, V _{IN} = 0V to V _{CC}	--	--	1	uA	
I _{OL}	Output Leakage Current	V _{CC} = Max, $\overline{CE} = V_{IH}$, or $\overline{OE} = V_{IH}$, V _{IO} = 0V to V _{CC}	--	--	1	uA	
V _{OL}	Output Low Voltage	V _{CC} = Max, I _{OL} = 2mA	V _{CC} =3.0V	--	--	0.4	V
			V _{CC} =5.0V				
V _{OH}	Output High Voltage	V _{CC} = Min, I _{OH} = -1mA	V _{CC} =3.0V	2.4	--	--	V
			V _{CC} =5.0V				
I _{CC}	Operating Power Supply Current	$\overline{CE} = V_{IL}$, I _{DQ} = 0mA, F = F _{max} ⁽³⁾	V _{CC} =3.0V	--	--	20	mA
			V _{CC} =5.0V			45	
I _{CCSB}	Standby Current-TTL	$\overline{CE} = V_{IH}$, I _{DQ} = 0mA	V _{CC} =3.0V	--	--	1	mA
			V _{CC} =5.0V			2	
I _{CCSB1}	Standby Current-CMOS	$\overline{CE} \geq V_{CC} - 0.2V$, V _{IN} $\geq V_{CC} - 0.2V$ or V _{IN} $\leq 0.2V$	V _{CC} =3.0V	--	0.25	1.5	uA
			V _{CC} =5.0V			1.5	

1. Typical characteristics are at TA = 25°C.

2. These are absolute values with respect to device ground and all overshoots due to system or tester noise are included.

3. F_{max} = 1/t_{RC}.

DATA RETENTION CHARACTERISTICS (TA = 0 to + 70°C)

SYMBOL	PARAMETER	TEST CONDITIONS	MIN.	TYP. ⁽¹⁾	MAX.	UNITS
V _{DR}	V _{CC} for Data Retention	$\overline{CE} \geq V_{CC} - 0.2V$ V _{IN} $\geq V_{CC} - 0.2V$ or V _{IN} $\leq 0.2V$	1.5	--	--	V
I _{CCDR}	Data Retention Current	$\overline{CE} \geq V_{CC} - 0.2V$ V _{IN} $\geq V_{CC} - 0.2V$ or V _{IN} $\leq 0.2V$	--	0.1	1	uA
t _{CDR}	Chip Deselect to Data Retention Time	See Retention Waveform	0	--	--	ns
t _R	Operation Recovery Time		T _{RC} ⁽²⁾	--	--	ns

1. V_{CC} = 1.5V, T_A = + 25°C



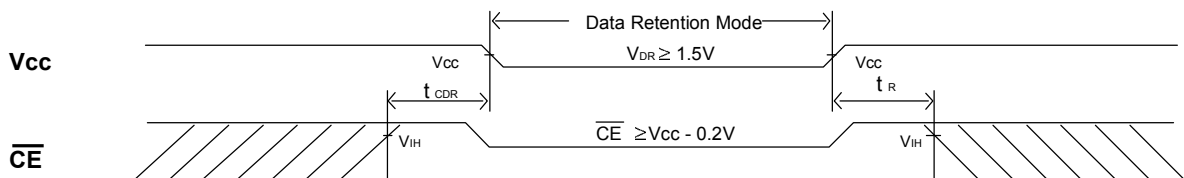

2. t_{RC} = Read Cycle Time

LOW V_{CC} DATA RETENTION WAVEFORM (\overline{CE} Controlled)

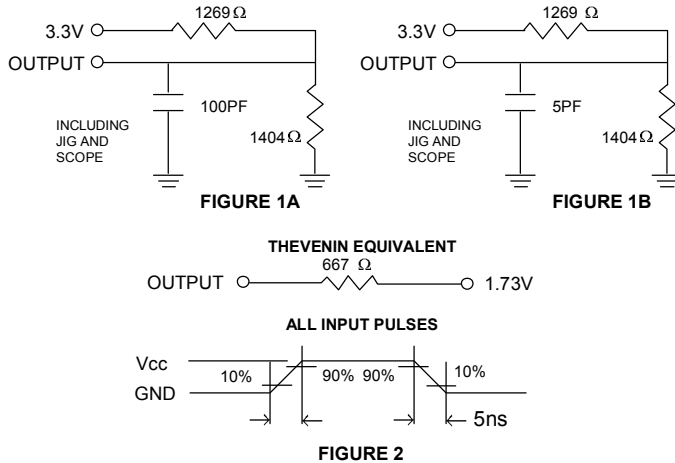
■ AC TEST CONDITIONS

Input Pulse Levels	Vcc/0
Input Rise and Fall Times	5ns
Input and Output Timing Reference Level	0.5Vcc

■ AC TEST LOADS AND WAVEFORMS

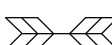
■ KEY TO SWITCHING WAVEFORMS

WAVEFORM	INPUTS	OUTPUTS
	MUST BE STEADY	MUST BE STEADY
	MAY CHANGE FROM H TO L	WILL BE CHANGE FROM H TO L
	MAY CHANGE FROM L TO H	WILL BE CHANGE FROM L TO H
	DON'T CARE: ANY CHANGE PERMITTED	CHANGE: STATE UNKNOWN
	DOES NOT APPLY	CENTER LINE IS HIGH IMPEDANCE "OFF" STATE

■ AC ELECTRICAL CHARACTERISTICS (TA = 0 to + 70°C , Vcc = 3.0V)
READ CYCLE

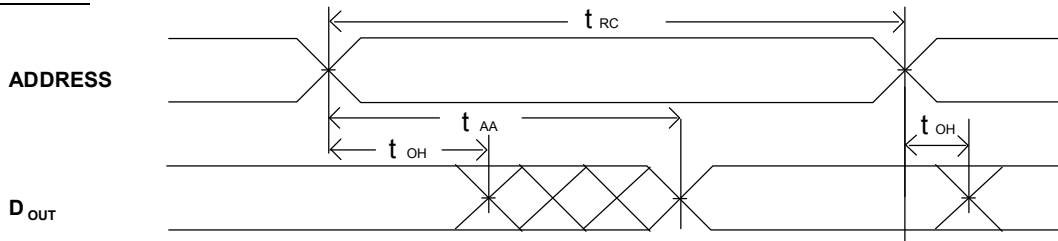
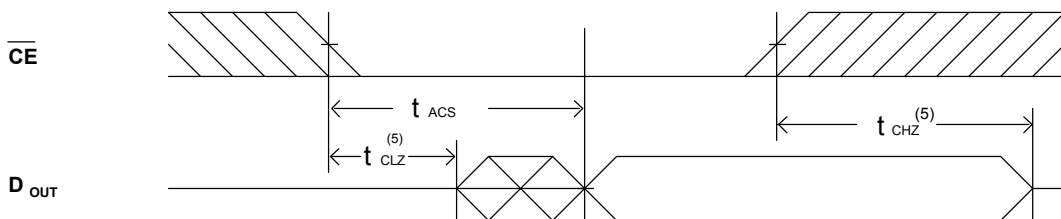
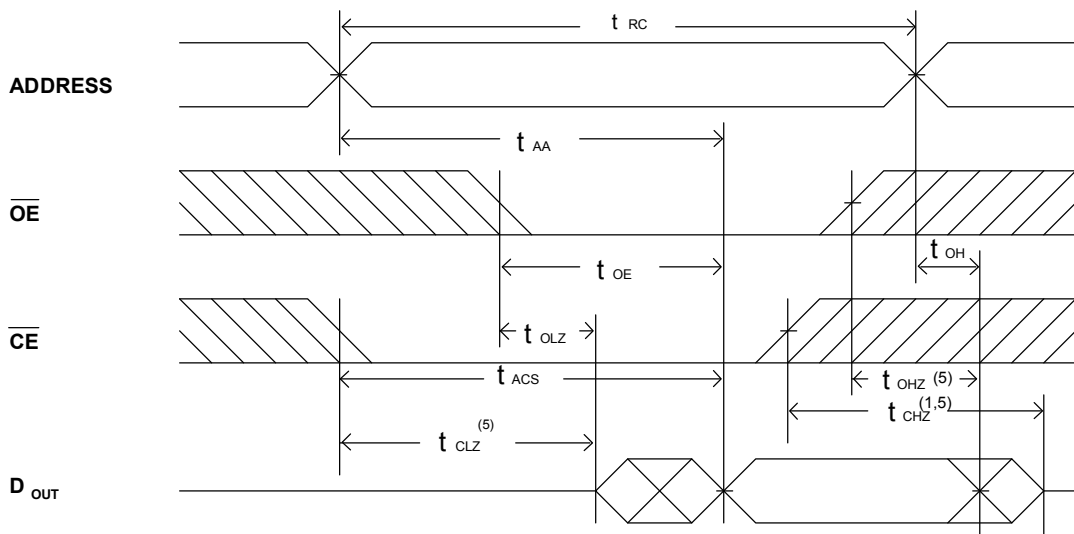
JEDEC PARAMETER NAME	PARAMETER NAME	DESCRIPTION	BS62LV4001-70			BS62LV4001-10			UNIT
			MIN.	TYP.	MAX.	MIN.	TYP.	MAX.	
t _{AVAX}	t _{RC}	Read Cycle Time	70	--	--	100	--	--	ns
t _{AVQV}	t _{AA}	Address Access Time	--	--	70	--	--	100	ns
t _{ELQV}	t _{ACS}	Chip Select Access Time	--	--	70	--	--	100	ns
t _{GLQV}	t _{OE}	Output Enable to Output Valid	--	--	35	--	--	50	ns
t _{ELQX}	t _{CLZ}	Chip Select to Output Low Z	10	--	--	15	--	--	ns
t _{GLQX}	t _{OLZ}	Output Enable to Output in Low Z	10	--	--	15	--	--	ns
t _{EHQZ}	t _{CHZ}	Chip Deselect to Output in High Z	0	--	35	0	--	40	ns
t _{GHQZ}	t _{OHZ}	Output Disable to Output in High Z	0	--	30	0	--	35	ns
t _{AXOX}	t _{OH}	Output Disable to Output Address Change	10	--	--	15	--	--	ns

SWITCHING WAVEFORMS (READ CYCLE)
READ CYCLE1 (1,2,4)

READ CYCLE2 (1,3,4)

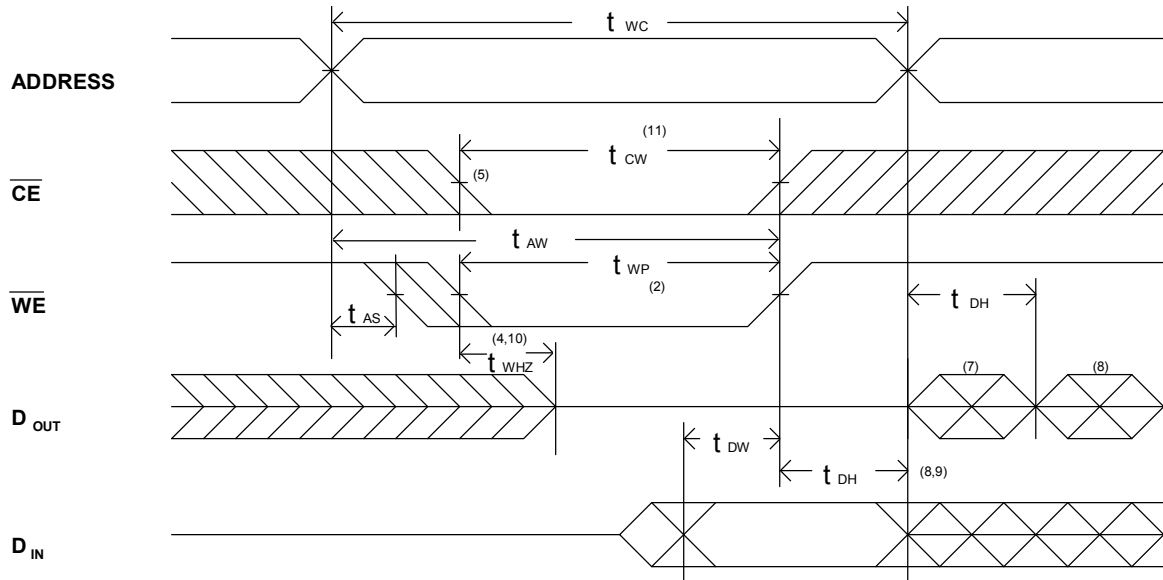
READ CYCLE3 (1,4)

NOTES:

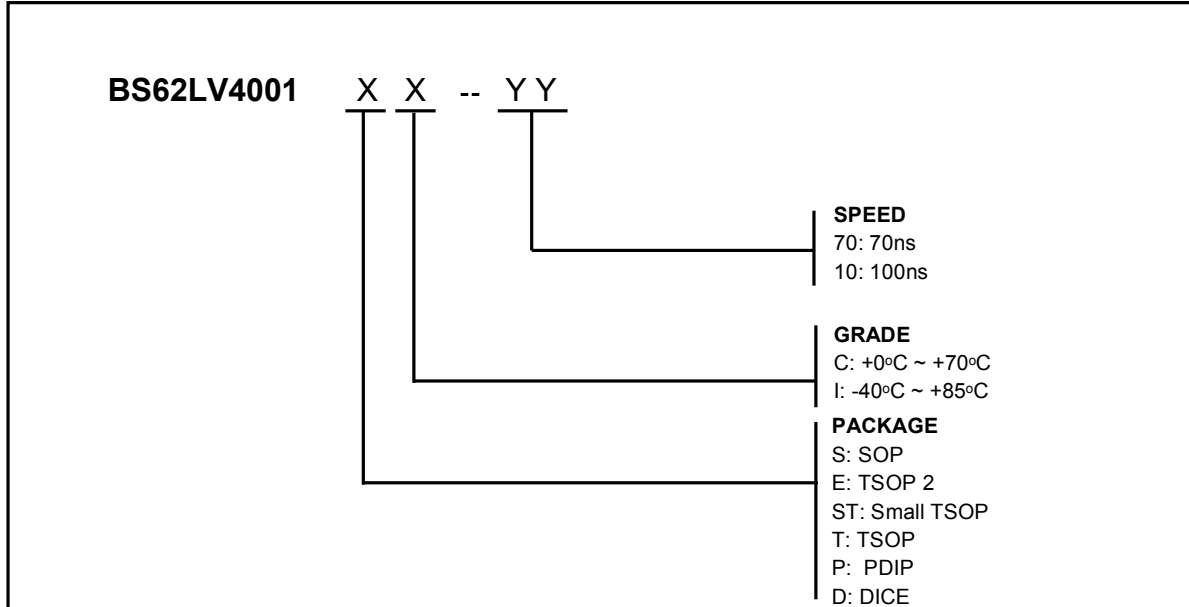
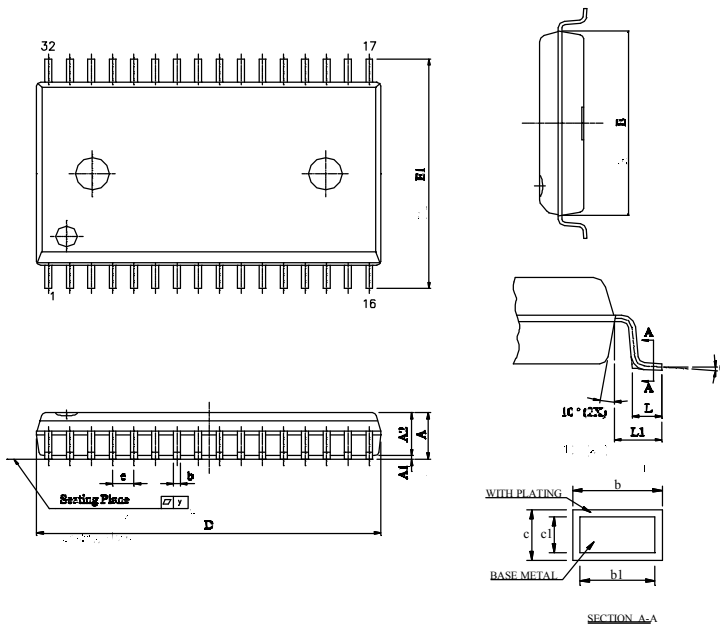
1. WE is high in read Cycle.
2. Device is continuously selected when $\overline{CE} = V_{IL}$.
3. Address valid prior to or coincident with \overline{CE} transition low.
4. $\overline{OE} = V_{IL}$.
5. Transition is measured $\pm 500mV$ from steady state with $C_L = 5pF$ as shown in Figure 1B. The parameter is guaranteed but not 100% tested.

WRITE CYCLE2 (1,6)

NOTES:

1. WE must be high during address transitions.
2. The internal write time of the memory is defined by the overlap of \overline{CE} and \overline{WE} low. All signals must be active to initiate a write and any one signal can terminate a write by going inactive. The data input setup and hold timing should be referenced to the second transition edge of the signal that terminates the write.
3. T_{WR} is measured from the earlier of \overline{CE} or \overline{WE} going high at the end of write cycle.
4. During this period, DQ pins are in the output state so that the input signals of opposite phase to the outputs must not be applied.
5. If the \overline{CE} low transition occurs simultaneously with the \overline{WE} low transitions or after the \overline{WE} transition, output remain in a high impedance state.
6. \overline{OE} is continuously low ($\overline{OE} = V_{IL}$).
7. D_{OUT} is the same phase of write data of this write cycle.
8. D_{OUT} is the read data of next address.
9. If \overline{CE} is low during this period, DQ pins are in the output state. Then the data input signals of opposite phase to the outputs must not be applied to them.
10. Transition is measured $\pm 500mV$ from steady state with $C_L = 5pF$ as shown in Figure 1B. The parameter is guaranteed but not 100% tested.
11. T_{CW} is measured from the later of \overline{CE} going low to the end of write.

ORDERING INFORMATION

PACKAGE DIMENSIONS

SYMBOL	UNIT	INCH	MM
A		0.111±0.007	2.821±0.176
A1		0.009±0.005	0.229±0.127
A2		0.1055±0.0055	2.680±0.140
b		0.014 ~ 0.020	0.35 ~ 0.50
b1		0.014 ~ 0.018	0.35 ~ 0.46
c		0.006 ~ 0.012	0.15 ~ 0.32
c1		0.006 ~ 0.011	0.15 ~ 0.28
D		0.805±0.005	20.447±0.127
E		0.445±0.005	11.303±0.127
E1		0.555±0.012	14.097±0.305
e		0.050±0.006	1.270±0.152
L		0.033±0.010	0.834±0.25
L1		0.055±0.008	1.397±0.203
y		0.004 Max.	0.1 Max.
θ		0° ~ 10°	0° ~ 10°

SOP -32

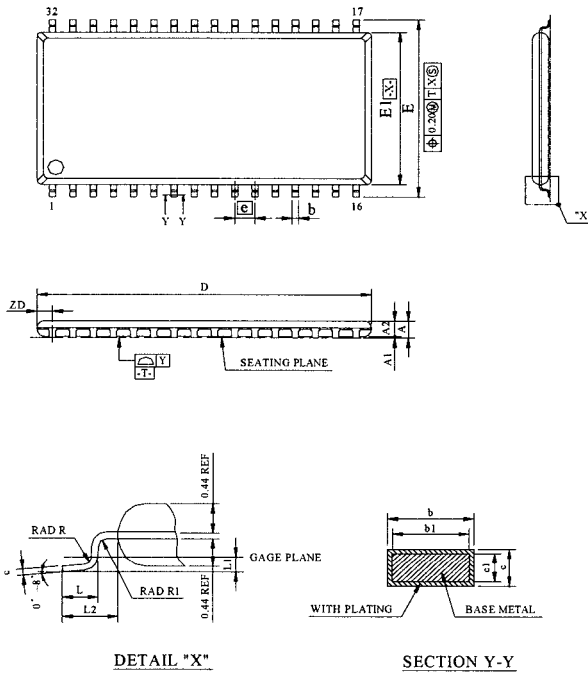
1



SYMBOL	DIMENSION (MM)			DIMENSION (INCH)		
	MIN.	NOM.	MAX.	MIN.	NOM.	MAX.
A			1.20			0.047
A1	0.05	0.10	0.15	0.002	0.004	0.006
A2	0.95	1.00	1.05	0.037	0.039	0.042
b	0.30		0.52	0.012		0.020
b1	0.30	0.40	0.45	0.012	0.016	0.018
e	0.12		0.21	0.005		0.008
e1	0.10	0.127	0.16	0.004	0.005	0.006
D	20.82	20.95	21.06	0.820	0.825	0.830
E	11.56	11.76	11.96	0.455	0.463	0.471
E1	10.03	10.16	10.29	0.394	0.400	0.405
Ⓞ	1.27 BASIC			0.050 BASIC		
L	0.40	0.50	0.60	0.016	0.020	0.024
L1	0.25 BASIC			0.010 BASIC		
L2	0.8 REF			0.031 REF		
R	0.12		0.25	0.005		0.010
R1	0.12			0.005		
ZD	0.95 REF			0.037 REF		
Y			0.10			0.004

- NOTE:
1. CONTROLLING DIMENSION - MILLIMETERS.
 2. REFERENCE DOCUMENT - JEDEC MS-024.
 3. DIMENSION D DOES NOT INCLUDE MOLD PROTRUSION. MOLD PROTRUSION SHALL NOT EXCEED 0.15(0.006") PERSIDE. DIMENSION E1 DOES NOT INCLUDE INTERLEAD PROTRUSION. INTERLEAD PROTRUSION SHALL NOT EXCEED 0.25(0.01") PER SIDE.
 4. DIMENSION b DOES NOT INCLUDE DAMBAR PROTRUSIONS/INTRUSION. ALLOWABLE DAMBAR PROTRUSION SHALL NOT CAUSE THE LEAD T BE WIDER THAN THE MAX b DIMENSION BY MORE THAN 0.13. DAMBAR INTRUSION SHALL NOT CAUSE THE LEAD T BE NARROWER THAN THE MIN b DIMENSION BY MORE THAN 0.07mm.

TSOP2 - 32

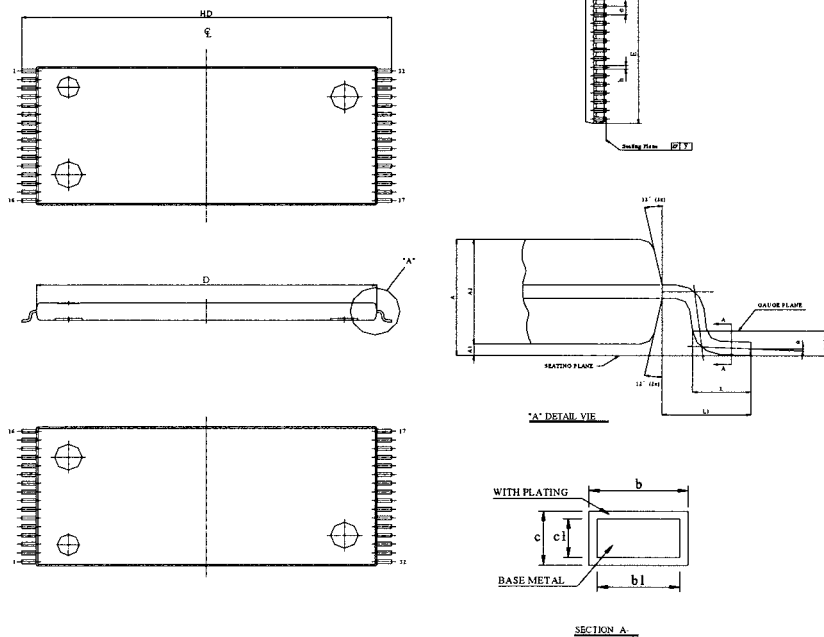

SYMBOL	UNIT	INCH	MM
A		0.0433 ± 0.004	1.10 ± 0.10
A1		0.004 ± 0.002	0.10 ± 0.05
A2		0.039 ± 0.002	1.00 ± 0.05
b		0.009 ± 0.002	0.22 ± 0.05
b1		0.008 ± 0.001	0.20 ± 0.03
c		0.004 ~ 0.008	0.10 ~ 0.21
c1		0.004 ~ 0.006	0.10 ~ 0.16
D		0.724 ± 0.004	18.40 ± 0.10
E		0.315 ± 0.004	8.00 ± 0.10
e		0.020 ± 0.004	0.50 ± 0.10
HD		0.787 ± 0.008	20.00 ± 0.20
L		0.0197 ^{+0.008} _{-0.004}	0.50 ^{+0.2} _{-0.1}
L1		0.0315 ± 0.004	0.80 ± 0.10
y		0.004 Max.	0.1 Max.
θ		0° ~ 8°	0° ~ 8°

TSOP - 32

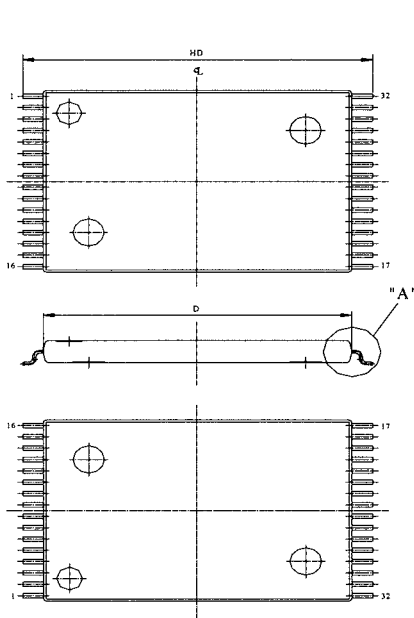
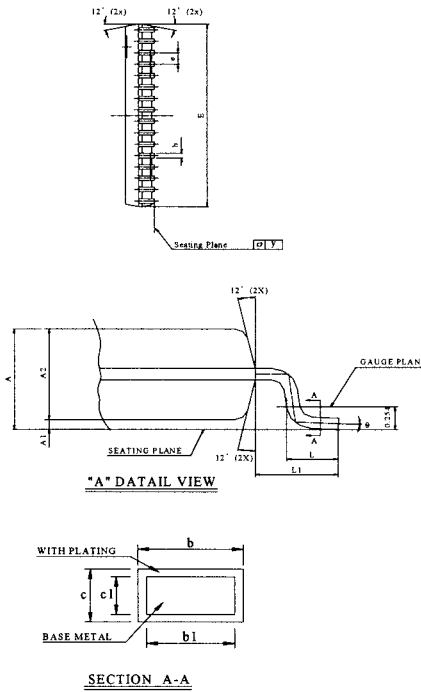
■ PACKAGE DIMENSIONS (continued)

STSOP - 32

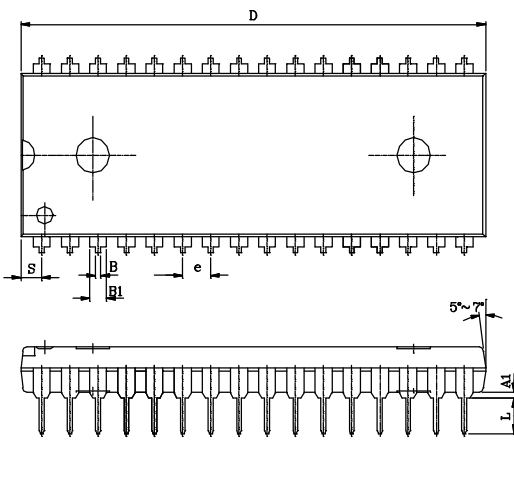
UNIT SYMBOL	INCH	MM
A	0.0433± 0.004	1.10± 0.10
A1	0.004± 0.002	0.10± 0.05
A2	0.039± 0.002	1.00± 0.05
b	0.009± 0.002	0.22± 0.05
b1	0.008± 0.001	0.20± 0.03
c	0.004 ~ 0.008	0.10 ~ 0.21
c1	0.004 ~ 0.006	0.10 ~ 0.16
D	0.465± 0.004	11.80± 0.10
E	0.315± 0.004	8.00± 0.10
e	0.020± 0.004	0.50± 0.10
HD	0.528± 0.008	13.40± 0.20
L	0.0197 ^{+0.008} / _{-0.004}	0.50 ^{+0.2} / _{-0.1}
L1	0.0315± 0.004	0.80± 0.10
y	0.004 Max.	0.1 Max.
θ	0° ~ 8°	0° ~ 8°

PDIP - 32

UNIT SYMBOL	INCH(BASE)	MM(REF)
A1	0.010(MIN)	0.254(MIN)
A2	0.154±0.005	3.912±0.127
B	0.018±0.005	0.457±0.127
B1	0.050±0.005	1.270±0.127
c	0.010±0.004	0.254±0.102
D	1.650±0.005	41.910±0.127
E	0.800±0.010	15.240±0.254
E1	0.544±0.004	13.818±0.102
e	0.100(TYP)	2.540(TYP)
eB	0.850±0.020	16.510±0.508
L	0.130±0.010	3.302±0.254
s	0.075±0.010	1.905±0.254
Q1	0.070±0.005	1.778±0.127

REVISION HISTORY

Revision	Description	Date	Note
2.2	2001 Data Sheet release	Apr. 15, 2001	
2.3	Modify Standby Current (Typ. and Max.)	Jun. 29, 2001	
2.4	To add DICE form	March 06, 2002	
2.5	Modify some AC parameters. Modify 5V ICCSB1_Max(I-grade) from 25uA to 50uA.	April,10,2002	