

## Array chip resistors size 4 × 0603

## ARC241/242 ARV241

### FEATURES

- 4 × 0603 sized resistors in one 1206-sized package
- Reduced reel exchange time
- Low assembly costs
- Reduced PCB area
- Reduced size of final equipment.

### APPLICATIONS

- Computers
- Microcomputer driven applications:
  - Portable radios
  - CD and cassette players
  - Car telephones
  - Camcorders
  - Cordless, cellular phones.

### DESCRIPTION

The resistors are constructed on a high grade ceramic body (aluminium oxide). Internal metal electrodes are added at each end and connected by a resistive paste which is applied to the top surface of the substrate. The composition of the paste is adjusted to give the approximate resistance required and the value is trimmed to within tolerance, by laser cutting of this resistive layer.

The resistive layer is covered with a protective coating and printed with the resistance value. Finally, external end terminations are added. For ease of soldering the outer layer of these end terminations is a lead/tin alloy.

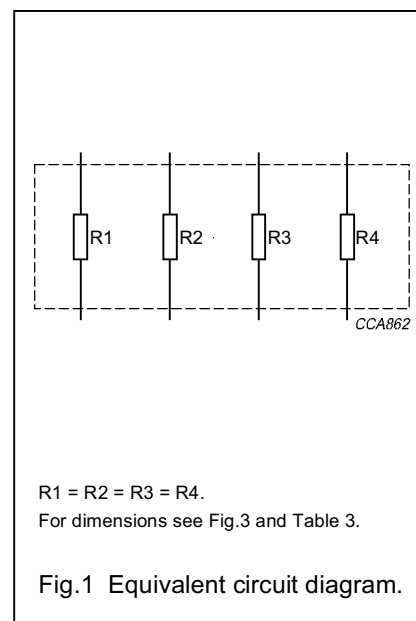

### QUICK REFERENCE DATA

DESCRIPTION	VALUE		
	ARC241	ARV241	ARC242
Resistance range	10 Ω to 1 MΩ		
Resistance tolerance and E-series	±5%; E24 series		±1%; E96 series
Temperature coefficient	≤±200 × 10 <sup>-6</sup> /K		≤±100 × 10 <sup>-6</sup> /K
Absolute maximum dissipation per resistive element at T <sub>amb</sub> = 70 °C	0.063 W		
Maximum permissible voltage	50 V (DC or RMS)		
Climatic category (IEC 60068)	55/155/56		
Basic specification	IEC 60115-8		

### R-Array overview

TYPE	TERMINATION TECHNOLOGY	SIZE	TOLERANCE (%)
ARC241	concave	4 × 0603	5
ARC242	concave	4 × 0603	1
ARV241	convex	4 × 0603	5

Array chip resistors  
size 4 × 0603

ARC241/242  
ARV241

## ORDERING INFORMATION

**Table 1** Ordering code indicating resistor type

TYPE	ORDERING CODE 2350 0.. .... <sup>(1)</sup>
	PAPER TAPE ON REEL
	5000 units
ARC241	34 10...
ARV241	35 10...
ARC242	24 1....
<b>Jumper 0 Ω</b>	
ARC241; note 2	34 91001
ARV241; note 2	35 91001

### Notes

- The arrays are supplied in paper tape on reel, 5000 units
- The jumper has a maximum resistance  $R_{\max} = 50 \text{ m}\Omega$  and a rated current  $I_R = 1 \text{ A}$ .

### Ordering code (12NC)

- The resistors have a 12-digit ordering code starting with 2350 0
- The subsequent three or four digits indicate the resistor termination style, tolerance and packaging; see Table 1.
- The remaining digits indicate the resistance value:
  - The first 2 digits for 5% or 3 digits for 1% tolerance products indicate the resistance value.
  - The last digit indicates the resistance decade in accordance with Table 2.

**Table 2** Last digit of 12NC

RESISTANCE	LAST DIGIT
10 to 91 Ω	9
100 to 910 Ω	1
1 to 9.1 kΩ	2
10 to 91 kΩ	3
100 to 910 kΩ	4
1 MΩ	5

### ORDERING EXAMPLE

The ordering code of an ARC241 resistor, value 100 Ω, supplied on paper tape of 5000 units per reel is: 2350 034 10101.

**Array chip resistors  
size 4 × 0603**

**ARC241/242  
ARV241**

**FUNCTIONAL DESCRIPTION**

**Product characterization**

Standard values of nominal resistance are taken from the E24 or E96 series for resistors with a tolerance of ±5% or ±1%. The values of the E24/E96 series are in accordance with "IEC publication 60063".

**Limiting values**

TYPE	LIMITING VOLTAGE <sup>(1)</sup> (V)	LIMITING POWER (W)
ARC241	50	0.063
ARC242		
ARV241		

**Note**

1. This is the maximum voltage that may be continuously applied to the resistor element, see "IEC publication 60 115-8".

**DERATING**

The power that the resistor can dissipate depends on the operating ambient temperature; see Fig.2.

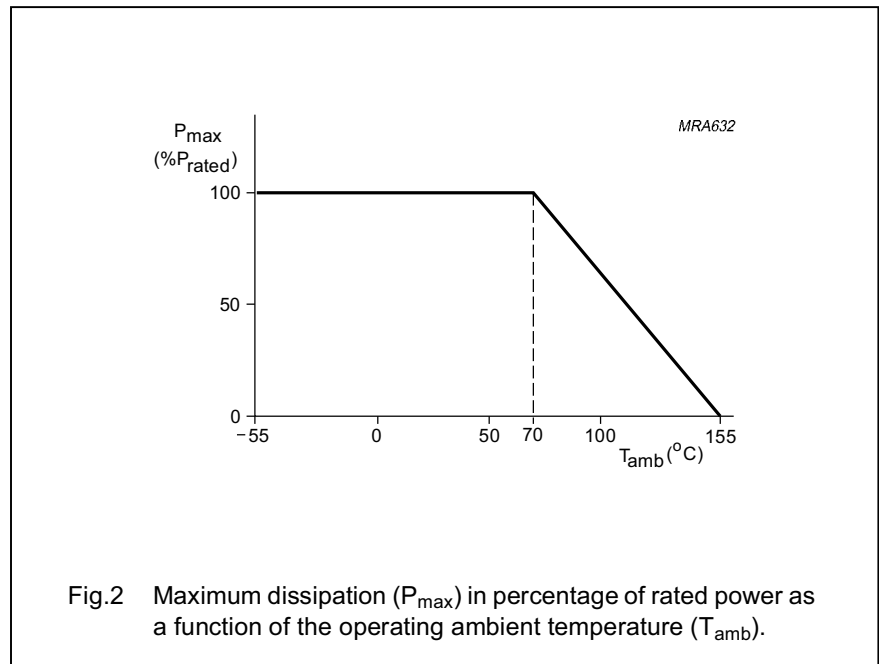

Fig.2 Maximum dissipation ( $P_{max}$ ) in percentage of rated power as a function of the operating ambient temperature ( $T_{amb}$ ).

Array chip resistors  
size 4 × 0603

ARC241/242  
ARV241

**MECHANICAL DATA**

**Mass per 100 units**

TYPE	MASS (g)
All types	1.1

**Marking**

All resistors within the E24 series are marked with a 3-digit code and a 4-digit code for resistors of the E96 series, on the protective coat to designate the nominal resistance value.

**3-DIGIT MARKING**

For values up to 91 Ω the R is used as a decimal point. For values of 100 Ω or greater the first 2 digits apply to the resistance value and the third indicates the number of zeros to follow.

**Example**

MARKING	RESISTANCE
12R	12 Ω
124	120 kΩ
000	jumper

**4-DIGIT MARKING**

For values up to 976 Ω the R is used as a decimal point. For values of 1 K or greater the first 3 digits apply to the resistance value and the fourth indicates the number of zeros to follow.

**Example**

MARKING	RESISTANCE
12R0	12 Ω
1203	120 kΩ

**PACKAGE MARKING**

The packaging is also marked and includes resistance value, tolerance, catalogue number, quantity, production period, batch number and source code.

**Outlines**

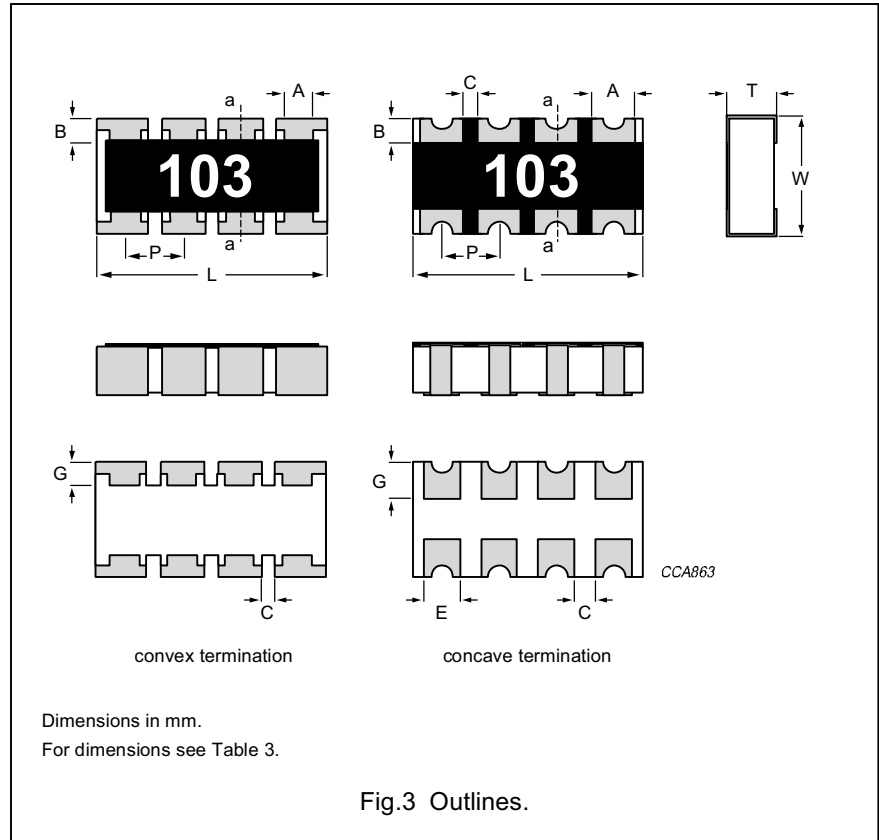

**Table 3** Physical dimensions; see Fig.3

SYMBOL	ARC241/242		ARV241		UNIT
	VALUE	TOL.	VALUE	TOL.	
L	3.20	+0.20/-0.10	3.20	±0.15	mm
W	1.60	+0.20/-0.10	1.60	±0.15	mm
T	0.60	±0.20	0.55	±0.10	mm
A	0.60	±0.15	0.40	±0.15	mm
B	0.35	±0.15	0.30	±0.20	mm
P	0.80	±0.15	0.80	±0.15	mm
E	0.50	±0.15	-	-	mm
G	0.50	±0.15	0.30	±0.15	mm
C	0.10	min.	0.10	min.	mm

## Array chip resistors size 4 × 0603

## ARC241/242 ARV241

### TESTS AND REQUIREMENTS

Essentially all tests are carried out in accordance with the schedule of "IEC publication 60115-8", category 55/155/56 (rated temperature range -55 to +155 °C; damp heat, long term, 56 days). The testing also covers the requirements specified by EIA, EIAJ and JIS.

The tests are carried out in accordance with IEC publication 60068, "Recommended basic

*climatic and mechanical robustness testing procedure for electronic components*" and under standard atmospheric conditions according to "IEC 60068-1", subclause 5.3.

Unless otherwise specified the following values apply:

Temperature: 15 °C to 35 °C

Relative humidity: 45% to 75%

Air pressure: 86 kPa to 106 kPa  
(860 mbar to 1060 mbar).

In Table 4 the tests and requirements are listed with reference to the relevant clauses of "IEC publications 60115-8 and 60068"; a short description of the test procedure is also given.

In some instances deviations from the IEC recommendations were necessary for our method of specifying.

All soldering tests are performed with mildly activated flux.

**Table 4** Test procedures and requirements

IEC 60115-8 CLAUSE	IEC 60068-2 TEST METHOD	TEST	PROCEDURE	REQUIREMENTS		
				ARC241	ARV241	ARC242
<b>Tests in accordance with the schedule of IEC publication 60115-8</b>						
4.4.1		visual examination		no holes; clean surface; no visible damage		
4.4.2		dimensions (outline; see Fig.3)	gauge (mm)	see Table 3		
4.5		resistance	applied voltage (+0/-10%): 10 Ω ≤ R < 100 Ω: 0.3 V 100 Ω ≤ R < 1 kΩ: 1 V 1 kΩ ≤ R < 10 kΩ: 3 V 10 kΩ ≤ R < 100 kΩ: 10 V 100 kΩ ≤ R < 1 MΩ: 25 V R ≥ 1 MΩ: 50 V	R - R <sub>nom</sub> : max. ±5%	R - R <sub>nom</sub> : max. ±5%	R - R <sub>nom</sub> : max. ±1%
4.18	20 (Tb)	resistance to soldering heat	unmounted chips; 10 ±1 s; 260 ±5 °C	no visible damage ΔR/R max.: ±(0.5% +0.05 Ω)		
4.29	45 (Xa)	component solvent resistance	isopropyl alcohol or H <sub>2</sub> O followed by brushing in accordance with "MIL 202 F"	no visible damage		
4.17	20 (Ta)	solderability	unmounted chips completely immersed for 2 ±0.5 s in a solder bath at 235 ±2 °C	good tinning (≥95% covered); no visible damage		
4.7		voltage proof on insulation	maximum voltage (RMS) during 1 minute, metal block method	no breakdown or flashover		
4.13		short time overload	room temperature; P = 6.25 × P <sub>n</sub> ; 5 s (V ≤ 2 × V <sub>max</sub> )	ΔR/R max.: ±(1% +0.05 Ω)		

Array chip resistors  
size 4 × 0603

ARC241/242  
ARV241

IEC 60115-8 CLAUSE	IEC 60068-2 TEST METHOD	TEST	PROCEDURE	REQUIREMENTS		
				ARC241	ARV241	ARC242
4.33		bending	resistors mounted on a 90 mm glass epoxy resin PCB (FR4), bending: 5 mm	no visible damage		
				$\Delta R/R$ max.: $\pm(1\% + 0.05 \Omega)$		$\Delta R/R$ max.: $\pm(0.5\% + 0.05 \Omega)$
4.19	14 (Na)	rapid change of temperature	30 minutes at LCT and 30 minutes at UCT; 5 cycles	no visible damage		
				$\Delta R/R$ max.: $\pm(0.5\% + 0.05 \Omega)$		
4.24.2	3 (Ca)	damp heat (steady state)	56 days; $40 \pm 2 \text{ }^\circ\text{C}$ ; 93 $\pm 2/-3\%$ RH; loaded with $0.01 P_n$	$\Delta R/R$ max.: $\pm(3\% + 0.1 \Omega)$		$\Delta R/R$ max.: $\pm(1\% + 0.05 \Omega)$
4.25.1		endurance	1000 $+48/-0$ hours; $70 \pm 2 \text{ }^\circ\text{C}$ ; loaded with $P_n$ or $V_{\text{max}}$ ; 1.5 hours on and 0.5 hours off	$\Delta R/R$ max.: $\pm(2\% + 0.1 \Omega)$		$\Delta R/R$ max.: $\pm(1\% + 0.05 \Omega)$
4.23.2	27 (Ba)	endurance at upper category temperature	1000 $+48/-0$ hours; no load	$\Delta R/R$ max.: $\pm(2\% + 0.1 \Omega)$		$\Delta R/R$ max.: $\pm(1\% + 0.05 \Omega)$
4.8.4.2		temperature coefficient	at 20/LCT/20 $^\circ\text{C}$ and 20/UCT/20 $^\circ\text{C}$	$\leq \pm 200 \times 10^{-6}/\text{K}$		$\leq \pm 100 \times 10^{-6}/\text{K}$
<b>Other tests in accordance with IEC 60115 clauses and IEC 60068 test method</b>						
4.17	20 (Ta)	solderability (after ageing)	8 hours steam or 16 hours 155 $^\circ\text{C}$ ; unmounted chips completely immersed for $2 \pm 0.5$ s in a solder bath at $235 \pm 2 \text{ }^\circ\text{C}$	good tinning ( $\geq 95\%$ covered); no damage		
4.6.1.1		insulation resistance	voltage (DC) after 1 minute, metal block method: 10 V	$R_{\text{ins}}$ min.: $10^3 \text{ M}\Omega$		
4.12		noise	IEC publication 60 195 (measured with Quantech-equipment)  $R \leq 100 \Omega$ $100 \Omega < R \leq 1 \text{ k}\Omega$ $1 \text{ k}\Omega < R \leq 10 \text{ k}\Omega$ $10 \text{ k}\Omega < R \leq 100 \text{ k}\Omega$ $100 \text{ k}\Omega < R \leq 1 \text{ M}\Omega$	max. $0.316 \mu\text{V}/\text{V}$ ( $-10 \text{ dB}$ ) max. $1 \mu\text{V}/\text{V}$ ( $0 \text{ dB}$ ) max. $3 \mu\text{V}/\text{V}$ ( $9.54 \text{ dB}$ ) max. $6 \mu\text{V}/\text{V}$ ( $15.56 \text{ dB}$ ) max. $10 \mu\text{V}/\text{V}$ ( $20 \text{ dB}$ )		

Array chip resistors  
size 4 × 0603

ARC241/242  
ARV241

IEC 60115-8 CLAUSE	IEC 60068-2 TEST METHOD	TEST	PROCEDURE	REQUIREMENTS		
				ARC241	ARV241	ARC242
<b>Other applicable tests</b>						
	(JIS) C 5202 7.5	resistance to damp heat (steady state)	1000 +48/-0 hours; 40 ±2 °C; 93 +2/-3% RH; loaded with P <sub>n</sub> or V <sub>max</sub> ; 1.5 hours on and 0.5 hours off	ΔR/R max.: ±(3% +0.1 Ω)		ΔR/R max.: ±(2% +0.1 Ω)
		leaching	unmounted chips 60 ±1 s; 260 ±5 °C	good tinning; no leaching		